

The Design and Optimization of a Crank-Based Leg Mechanism

Amanda Ghassaei
Professors Phil Choi and Dwight Whitaker
Pomona College Department of Physics and Astronomy
April 20, 2011

Table of Contents

Abstract.....	iii
Acknowledgements.....	iv
Chapter 1: Introduction.....	1
1.1 Summary of Paper.....	1
1.2 Advantages of Walking.....	1
1.3 Objectives.....	3
Chapter 2: Theory.....	5
2.1 Introduction.....	5
2.2 Crank Based Walking Mechanisms.....	5
2.3 Gait Selection for 2n-Walking Mechanism.....	12
Chapter 3: Survey of Walking Mechanisms and Analysis in Mathematica.....	23
3.1 Introduction.....	23
3.2 Hrones-Nelson Mechanism.....	24
3.3 Theo Jansen Mechanism.....	25
Chapter 4: Design and Analysis of Walking Mechanism.....	45
4.1 Introduction.....	45
4.2 Design Process.....	46
Chapter 5: Optimization of Walking Mechanism.....	55
5.1 Introduction.....	55
5.2 Symmetry of Design.....	56
5.3 Four Bar Linkage #1 Optimization.....	57
5.4 Full Linkage Optimization.....	59
Chapter 6: Analysis and Comparison with Theo Jansen.....	63
6.1 Introduction.....	63
6.2 Position Plots.....	63
6.3 Locus Analysis.....	67
6.4 Center of Mass.....	70
6.5 Analysis of Linkage Pair.....	72
6.6 Comparison with Theo Jansen Mechanism.....	76
Chapter 7: Construction and Conclusions.....	79
7.1 Introduction.....	79
7.2 Construction.....	79
7.3 Comparison with Theoretical Model.....	96
7.4 Possible Improvements/ Future Work.....	97
Appendix A: Mathematica Code.....	98
Appendix B: Theo Jansen Analysis.....	146
Appendix C: Optimization of Four Bar Linkage #1.....	151
Appendix D: Optimization of Four Bar Linkage #2.....	161
Works Cited.....	168

Abstract

This paper describes the design and fabrication process of a $2n$ -legged passive walker based on the work of Theo Jansen; the primary focus of this paper is the design of a crank-based leg linkage. The linkage was simulated in Mathematica, and an analysis of the leg design, including an analysis of the foot path and center of mass is provided and compared to the Theo Jansen mechanism. The results of the comparison found that the foot path of the new design is flatter and has a more constant velocity when it is in contact with the ground and the leg linkage requires 85% less vertical center of mass movement during locomotion than the Theo Jansen mechanism, but its step height is about 33% less. A detailed description of the fabrication of a six-legged walker made primarily from PVC tubing is given, as well as suggestions for improvement and future work.

I would like to thank David Haley, Glenn Flohr, Tony Grigsby, Cathi Combras, Jenna deBoisblanc, Phil Choi, Dwight Whitaker, and the rest of the Pomona Physics and Astronomy Department for their contributions to this project.

Chapter 1: Introduction

1.1 Summary of Paper

The purpose of this paper is to describe the design and construction process of a 2n-legged walking machine suitable for locomotion in variable terrain. In this paper I will accomplish the following:

- A discussion of crank-based linkages for the purpose of walking.
- An introduction to gait analysis.
- A quantitative and qualitative analysis of crank-based linkage examples and an assessment their suitability for walking.
- An outline of my design objectives.
- A quantitative and qualitative analysis of my design.
- An explanation of the optimization process.
- A description of the techniques I used to build a physical model of my linkage.
- A discussion of possible improvements on my design and future work.

1.2 Advantages of Walking

Walking machines possess several advantages over wheeled machines in areas of variable terrain. Consider a wheel moving a constant velocity \mathbf{V} ; every point on its perimeter is moving at a constant velocity \mathbf{V} tangent to the curve of the wheel as shown in Figure 1.2.1. A comparable walking mechanism would be one which moves at a constant velocity \mathbf{V} , and where the “foot” of the walker traces out a similar circular path with a constant velocity \mathbf{V} at all points on the path (also shown in Figure 1.2.1). The most obvious advantage of the foot over the wheel is that the foot may step over inconsistencies in the terrain. Local maxima and minima may be completely avoided by simply stepping over them. This results in less loss of energy during locomotion and allows the vehicle to maintain a constant velocity and height over variable terrain.

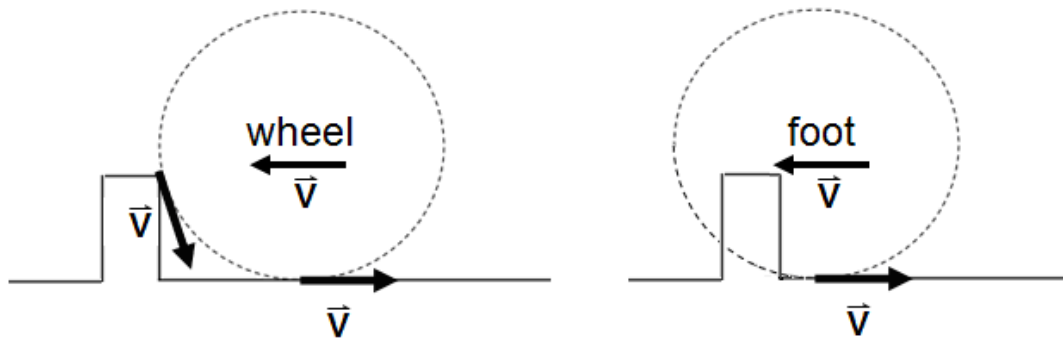

Figure 1.2.1: Comparison of wheel and foot response to a local maximum in the terrain. The dotted lines indicate the perimeter of the wheel or the path of the foot. The arrows indicate the direction of movement. The foot may step over the obstacle completely, while the wheel must move over the obstacle.

Now consider a case where the comparable foot and wheeled systems approach an obstacle that cannot be avoided, as shown in Figure 1.2.2. When the edge of the wheel makes contact with the higher ground, it forces the velocity of the vehicle to immediately slow. This edge has a total velocity \mathbf{V} , but only a fraction of that velocity is in the x direction, so the vehicle quickly slows from \mathbf{V} to V_{x2} . The foot encounters a similar change in velocity, but it has the advantage of being able to slide along the ground. Although this scenario is not ideal, dragging the front foot across the raised terrain reduces change of velocity in the x direction. Both models must still overcome the potential energy barrier posed by the increased height of the terrain.

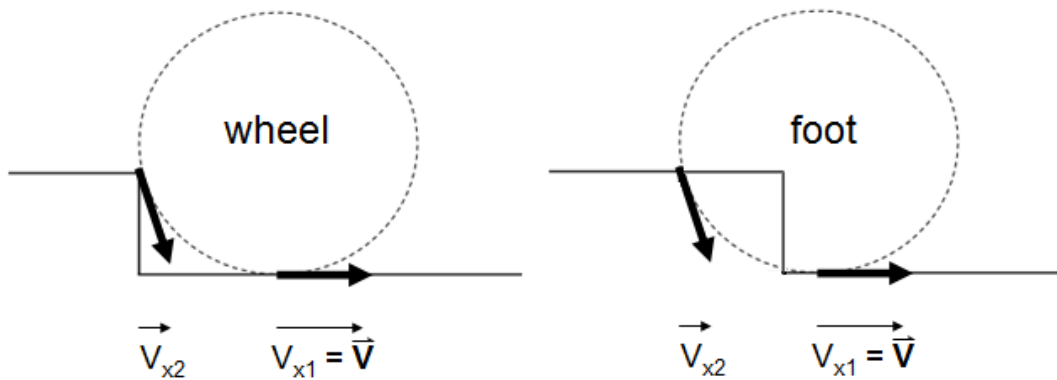

Figure 1.2.2: A comparison of a wheel and a foot (moving in a wheel-like path) approaching an inconsistency in the terrain. The x component of the velocity of the edge of the wheel and the foot's path are indicated.

Furthermore, the wheel causes a great deal of environmental harm³. Its inability to avoid obstacles means that it erodes more terrain than a foot when moving comparable

vehicles. Additionally, wheeled vehicles work best on terrain with no inconsistencies; this has led to paving of many permanent roadways, another form of environmental degradation.

The benefits of walking over rolling on rough terrain are summed up in the following:

- Higher energy efficiency, better fuel economy
- Increased speed
- Greater mobility
- Improved isolation from terrain inconsistencies
- Less environmental damage (both from paving and erosion)

1.3 Objectives

The aim of this project is to create an energy efficient mechanism for the movement of a vehicle over variable terrain. My objectives are discussed below:

- Energy efficiency

In my design I want to minimize the amount of energy used per locomotive cycle. I will accomplish this by designing a linkage which minimizes torque on the crank and sequencing a gait in which the upward movement of one leg is cancelled out by the downward movement of another leg; this necessitates that the walker have $2n$ legs. Additionally, these legs must be attached to a central crank axis (as seen in Figure 1.3.1) so that they can be coupled. The legs will all be directly coupled to the same crank axis. The linkage will also allow the main body of the vehicle to remain at a constant height throughout locomotion, which will minimize energy losses due to changing potential energy.

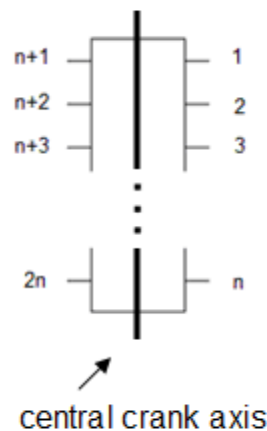

Figure 1.3.1: Diagram of $2n$ legged walker with central crank axis labeled.

- Ability to avoid obstacles by stepping over them

As I explained in the previous section, the main reason for choosing a walking mechanism over a wheel is that it has the ability to avoid obstacles. The linkage must be designed in order to maximize this advantage.

- Statically stable during entire locomotive cycle

It is my aim to make a vehicle that is not prone to falling over. If the vehicle should come to a stop at any point in the locomotive cycle, the vertical projection of its center of mass must always be inside its base of support.

- Durable joints/hinges/moving parts which will not become blocked by debris over time

Since this walker will be moving across uneven terrain, it will most likely encounter obstacles that it cannot avoid. The linkage must be able to handle the stresses of irregularities in the terrain. The vehicle will be walking outdoors so the linkage should not include cam grooves or other parts that may become blocked by debris.

- Inexpensive materials

I am working with a limited budget, so I would like to design a mechanism that can be built with inexpensive materials. This means limiting the use of parts such as bearings, hinges, springs... etc.

- No control mechanism necessary

This mechanism will not be operated by a computer or a person via a hydraulic system. Instead, it is my intention to build a walker with a passive, periodic gait for the purpose of simplicity.

Chapter 2: Theory

2.1 Introduction

In this chapter I will describe the principles behind the design of a mechanical walking linkages and gait analysis. I will introduce terms and diagrams that are useful for describing and analyzing walking linkages and gaits.

2.2 Crank Based Walking Mechanisms

2.2.1 Introduction

In this section I will examine the desirable and undesirable traits of crank based walking mechanisms for the purpose of energetically efficient and stable locomotion over moderately variable terrain. A linkage is “crank-based” when the circular movement of one point in the linkage translates to movement elsewhere in the linkage; this means the circularly moving part of the linkage can be attached to a crank so that the motion of the mechanism is easily driven (shown in Figure 2.2.1).

2.2.2 Definitions

The foot of a walking mechanism is the part of the mechanism that comes in direct contact with the ground as indicated in Figure 2.2.1. As the crank turns, the foot traces out a cyclical path relative to the body of the walker; this path is known as the locus.

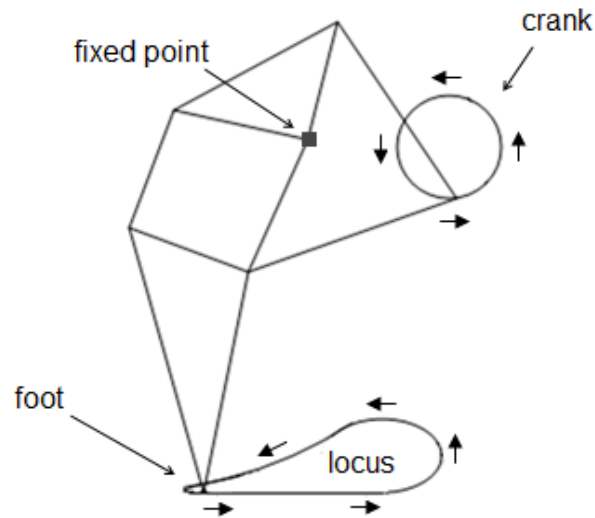

Figure 2.2.1: A crank based leg system with the foot, locus, and crank labeled. The direction of movement of the linkage to the crank and the foot through the locus are indicated. Additionally, a fixed point in the linkage relative to the body of the walker is indicated with a black square.

The locus can be divided into four parts: the support, lift, return, and lower phases. These phases are illustrated in Figure 2.2.2. Throughout the support phase, the foot is ideally in contact with the ground. During the lift the foot is moving toward its maximum height in the locus. During the return, the foot reaches its maximum height off the ground and moves in the same direction as the body of the walker. Finally, during the lower the foot descends in height until it makes contact with the ground.

The step height is the height of the foot off the ground when it enters the lower phase and is shown in Figure 2.2.2.

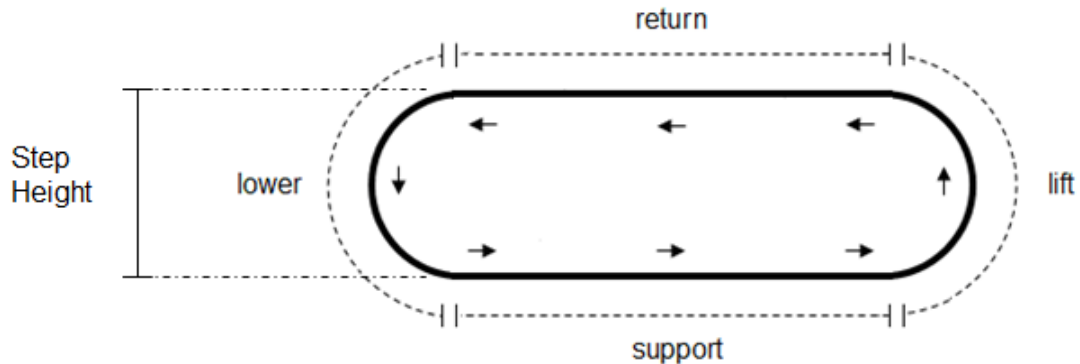

Figure 2.2.2: A theoretical foot locus is traced out by the bold black line with arrows indicating the direction of motion of the foot through the locus. Step height and lift, return, lower, and support phases are labeled.

2.2.3 Desirable Traits of a Walking Mechanism

In this section I will discuss the traits that will be selected for in the design and optimization of my walking mechanism. Many of these traits are described in Shigley² and relate to both energy efficiency and suitability of a leg mechanism for walking. The traits are listed below:

- The locus must have a uniform velocity during the support phase.

While the feet of the walker are in contact with the ground, their acceleration relative to the body of the walker is ideally zero. This ensures that the acceleration of the walker relative to the ground is also zero. This is more energetically favorable because it decreases the chance of dragging one or more of the feet during the locomotion cycle (ideally the velocity of the foot relative to the ground during the support phase is zero). Additionally, acceleration and deceleration of the body of the walker during the locomotive cycle is energetically taxing and should therefore be minimized.

- The crank must have a uniform angular velocity during the entire locomotive cycle.

Since the legs of the walker will be offset by a constant crank phase relative to each other, it is important that the crank undergo zero acceleration during the locomotion cycle. This will ensure that the feet of all the legs are moving through the locus with identical velocity and acceleration at each point in the locus so that uniform velocity of the support phase may be satisfied for all feet. Additionally, acceleration and deceleration of the crank is energetically taxing and should therefore be minimized.

- The inertial forces and inertial torques on the crank should be balanced during the full locomotion cycle

This follows directly from the previous statement. If the net force on the crank is zero, then it will have constant velocity.

- The energy required for the lift should be recovered by the lower.

Pairing of the lift and lower phases of the legs will increase energy efficiency and help to minimize the net forces on the crank.

- The ratio of the duration of the support phase to the duration of the full leg cycle is greater than or equal to 0.5.

The purpose of this paper is to design a statically stable walker. Therefore, it is advantageous that the leg system maximize the amount of time that a foot spends in contact with the ground to increase stability throughout the gait.

- The spatial length of the support phase (the length of the stride) must be long compared with the dimensions of the walker.

In order to be energy efficient, the walker must maximize the distance moved per unit of energy lost. Increasing the stride length will help accomplish this because each locomotive cycle will result in more forward movement.

- The step height must be large compared with the dimensions of the walker

This paper is concerned with designing a walker that moves over moderately variable terrain. Therefore, the step height of the locus of all the feet should be high enough to step over minor inconsistencies in the terrain in order to prevent foot dragging.

- The locus should have a high step height in both directions.

It is my intention to design a walker that is symmetric about a central crank axis (see Figure 2.2.4). However, as shown in Figure 2.2.4, this means that the loci of identical leg linkages in a pair on the crank will be mirror images of each other. If the locus is not symmetric, then the step height of one leg may be considerably larger than the other as the walker moves both forward and backward.

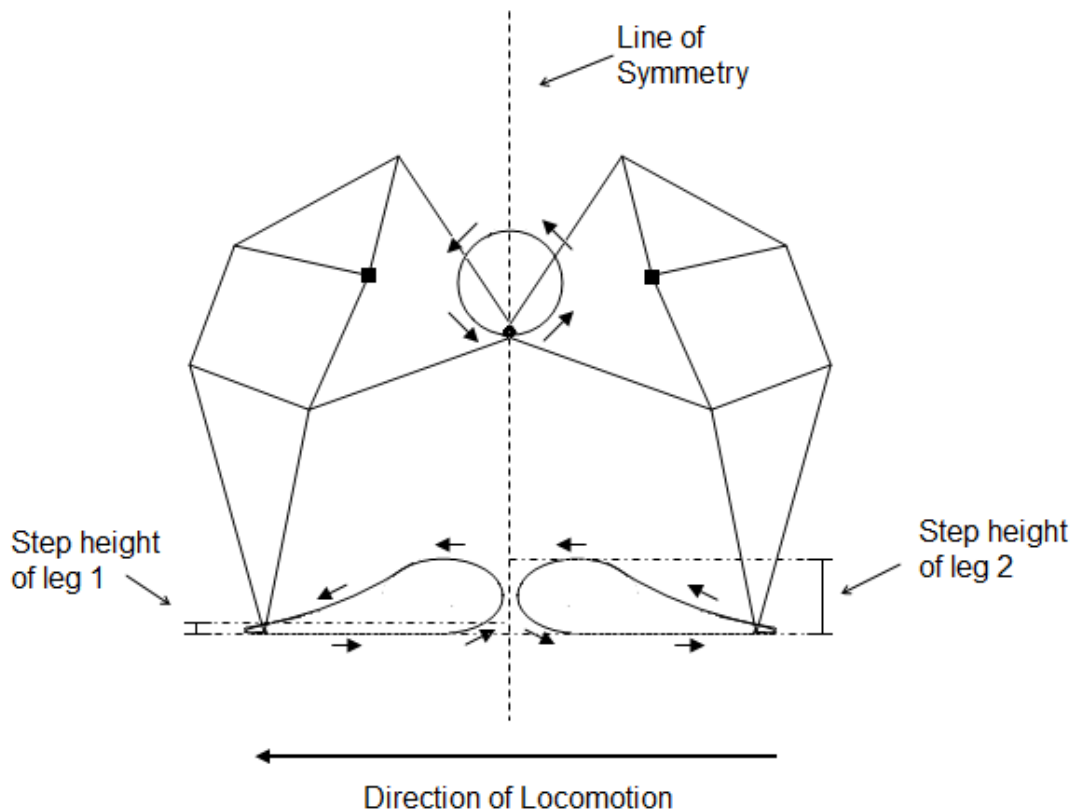

Figure 2.2.4: A cross section of a walker with a central crank axis shows that the loci of each pair of legs are mirror images of one another. Since the locus for this linkage is not symmetric, the step height of leg 1 is considerably smaller than that of leg 2. If this walker were to walk in the reverse direction, then the step height of leg 2 would be considerably smaller than that of leg 1. Arrows indicate the movement of the crank and the movement of the feet through the loci. The direction of locomotion of the walker is also indicated.

2.2.4 Desirable Traits of a Locus

Consider the coordinate system of the locus of Figure 2.2.5 in which the direction of locomotion is the x axis and the vertical direction is the y axis.

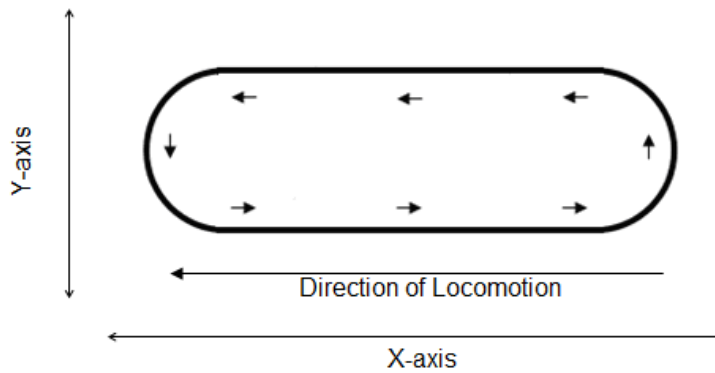

Figure 2.2.5: Locus with direction of locomotion, and x and y axes indicated.

If we consider a simple scenario where the velocity of the foot tangent to the locus path stays constant, then we can write the x component of the velocity vector of the foot to the terrain (V_{FTx}) as a sum of the x components of the velocity vectors of the walker to the terrain (V_{WTx}) and the foot to the walker (V_{FWx}).

$$V_{FTx} = V_{WTx} + V_{FWx}$$

When the foot is in the support phase the velocity of the foot relative to the ground equals zero:

$$V_{FTx} = 0$$

Then, during the support phase, we have the relationship:

$$V_{WTx} = -V_{FWx}$$

This means that during the support phase the velocities of the walker to the terrain and the foot to the walker have equal magnitude and opposite direction. Assuming that all four phases of the locus have equal time durations and the acceleration of the foot through the lift and lower phases is characteristic of a wheel then we can generate the graph of Figure 2.2.6.

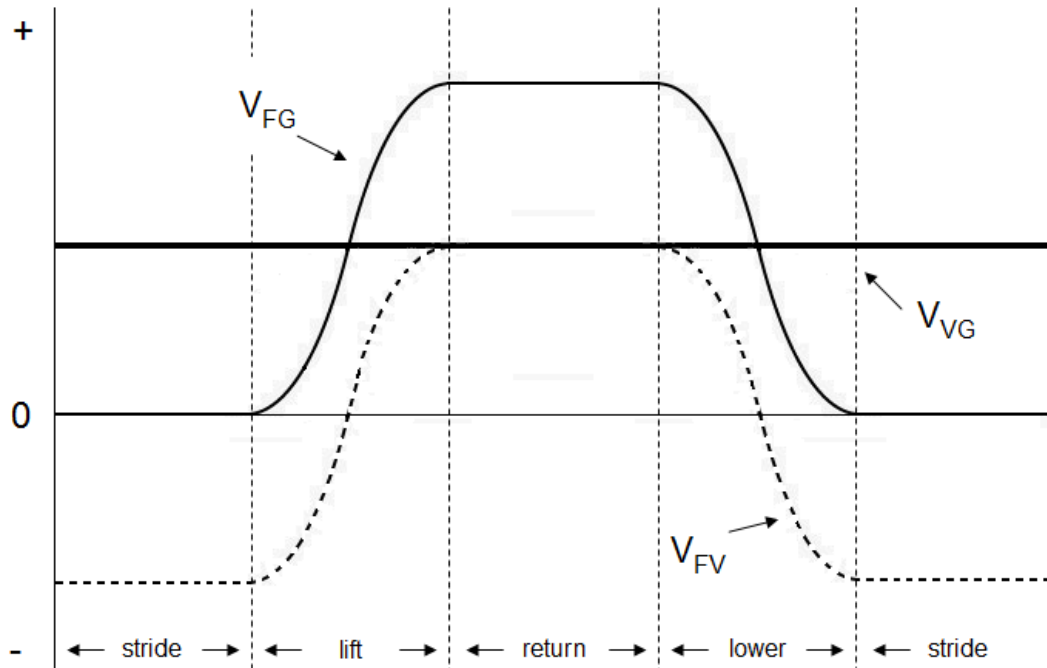

Figure 2.2.6: A plot of the V_{FG} (the velocity of the foot relative to the ground), V_{VG} (The velocity of the vehicle relative to the ground), and V_{FV} (the velocity of the foot to the vehicle) for an entire locomotive cycle. Stride, lift, return, and lower phases are indicated.

By examining Figure 2.2.6, we can see that V_{FG} equals zero during the support phase, as it should. During the return phase the foot is moving twice as fast as the vehicle, and in the same direction. The most important thing to note from this graph is that during the first half of the lift phase and the last half of the lower phase, the foot is moving slower than the vehicle. This means that if the foot comes in contact with the ground during this time it will be dragged; this is much more likely to occur during the lower phase.

Five theoretical loci are illustrated in Figure 2.2.7. Each locus is made of a unique combination of support, lift, return, and lower phases. The lift and lower phases are important to consider because of how they affect the velocity and acceleration at the beginning and end of the support phase. Additionally, the lower phase determines the step height of the walker. The shape of the return is not important, but it should have minimum acceleration and maximum symmetry so that inertial forces on the crank can be more easily balanced.

The symmetry of locus A in Figure 2.2.7 means that inertial effects on the crank will be minimized by properly offsetting the relative phase of the legs in the walker. Its lift and lower phases resemble that of a wheel; ideally, their acceleration characteristics should resemble that of a wheel. However, it will not make for an energy efficient walking mechanism because the length of the support phase is small.

The loci of Figure 2.2.7 B and C require a great amount of acceleration at their pointed ends. Locus b is especially undesirable because of its low step height; it may

have problems stepping over irregularities in terrain or cause dragging if it makes contact with the ground during the lower.

The rectangular locus in Figure 2.2.7 E has a lift and lower which quickly brings the foot on and off the ground, however, it requires infinite acceleration at the beginning and end of the support phases in order to achieve constant velocity through the support. Furthermore, if the foot were to make contact with a local maximum in the terrain during the lower phase, it would result in dragging on the vehicle.

The locus of Figure 2.2.7 D is the ideal locus. It has the symmetry and wheel-like lift and lower phases of locus a with the longer support phase of locus E.

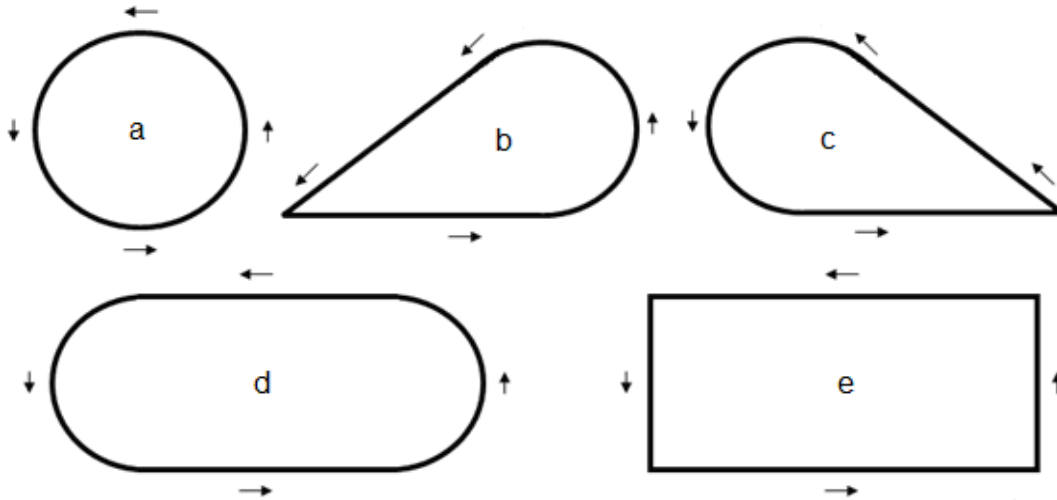

Figure 2.2.7: Five theoretical foot loci with arrows indicating the direction of the foot's movement. The ideal locus path is given by locus D.

2.3 Gait Selection for a 2n-legged walking machine

2.3.1 Introduction to Gait Selection

In this section I will introduce definitions and theory associated with periodic 2n-legged gaits. A gait describes the positions of all the legs of a multi-legged system during a full locomotive cycle. Energy efficiency and stability must both be considered when selecting the gait of a multi-legged walking machine. Maximizing energy efficiency with a crank-based walking mechanism means adjusting the relative phase of each leg in the walker so that torque on the crank is minimized; ideally the crank will rotate with a constant velocity. Maximizing stability means sequencing the stepping of each leg so that the gait is statically stable by the largest margin possible throughout the entire locomotive cycle.

2.3.2 Definitions

Consider a longitudinal $2n$ -legged walker as depicted in Figure 2.3.1. The walker is designated as a longitudinal walker because its direction of locomotion is parallel to its longitudinal axis. In this paper I will follow a leg numbering system that always numbers the leading left leg as leg 1 or leg_1 . From there, all legs on the left side of a longitudinal walker are numbered as $leg_{(2m+1)}$ where m ranges from 0 to $(n-1)$ and indicates the number of legs which are located directly in front of a given leg. For example, the leg labeled 5 in Figure 2.3.1 has two legs directly in front of it (leg_3 and leg_1), so $m = 2$ for this leg and $2m+1 = 5$; then it is numbered leg_5 . Similarly, the legs on the right side of a longitudinal walker are numbered $leg_{2(m+1)}$.

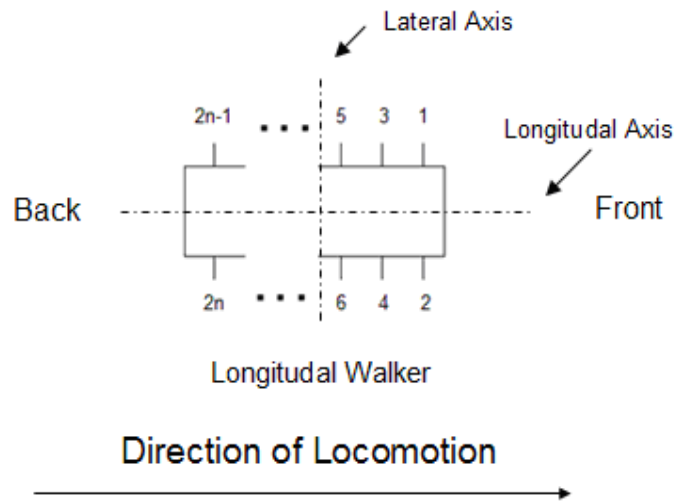

Figure 2.3.1: A longitudinal $2n$ -legged walker with leg numbering system, longitudinal and lateral axes, front and back, and the direction of locomotion indicated.

In the last section, we described the locus of a leg linkage in terms of four phases; support, lift, return, and lower. In gait analysis, it is more useful to combine the lift, return, and lower phases into the transfer phase and describe the locus in terms of the transfer and support phases. The support phase is still defined as in the last section, when the foot is in direct contact with the ground. Then, when the foot of leg_i is not in contact with the ground, it is in the transfer phase. These definitions are illustrated in Figure 2.3.2. Since leg_i must be in either the transfer phase or the support phase at all times, the sum of the durations of each of these phases is equal to the total length of one cycle of leg_i . That is,

$$\text{duration of transfer phase of } leg_i + \text{duration of support phase of } leg_i = \text{full cycle time of } leg_i$$

In this paper, I will normalize the durations of the transfer and support phases so that the time duration of one locomotive cycle is equal to one. Then,

$$\text{normalized transfer phase of } leg_i + \text{normalized support phase of } leg_i = 1$$

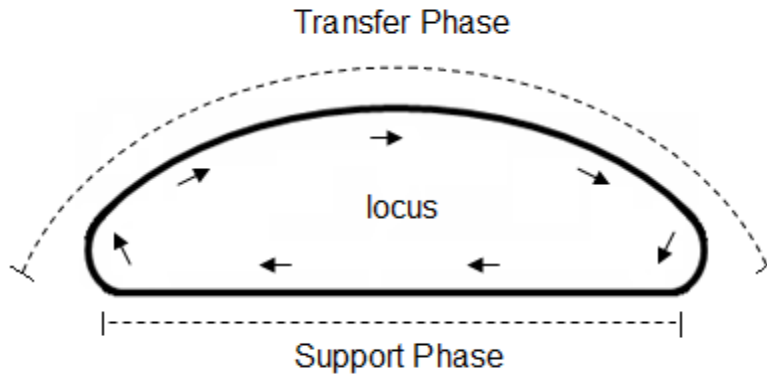

Figure 2.3.2: An illustration of the transfer and support phases of a leg during a complete leg cycle. The path traced out by the foot of the leg (relative to the body of the walker) is shown in solid black, with arrows indicating the direction of the foot's movement. During the support phase the foot is ideally always in contact with the ground, and during the transfer phase the foot is ideally never in contact with the ground.

A locomotive cycle of a periodic gait is the time it takes for each leg of a walking machine to complete a full leg cycle. When all the legs of the walker have the same leg cycle time, the locomotive cycle has the same duration as a leg cycle. During this time each leg on the machine has completed exactly one lifting event and exactly one placing event. A placing event is defined as the movement of the foot from the transfer phase to the support phase, and a lifting event is the movement of the foot from the support phase to the transfer phase.

The duty factor, β_i , is the ratio of the duration of the support phase of leg_i to the cycle time of leg_i .

$$\beta_i = (\text{duration of support phase of } \text{leg}_i) / (\text{cycle time of } \text{leg}_i)$$

This is also equal to the normalized duration of the support phase of leg_i .

$$\beta_i = \text{normalized duration of the support phase of } \text{leg}_i$$

The leg phase, ϑ_i , of leg_i is the fraction of a leg cycle that the placing event of leg_i lags behind the placing event of leg_1 in a locomotive cycle. We are free to designate:

$$\vartheta_1 = 0$$

In this paper ϑ_i is normalized to the duration of the leg cycle so that:

$$0 \leq \vartheta_i < 1$$

When determining the stability of a gait through the locomotive cycle, it is useful to consider the stability pattern. The stability pattern of a walker is the polygon created by drawing a line between adjacent legs in the support phase at any moment during the locomotion cycle. An example of a stability pattern for a six-legged walker is shown in Figure 2.3.3. In the diagram only five legs are in the support phase, as indicated by the numbers at the vertices of the polygon.

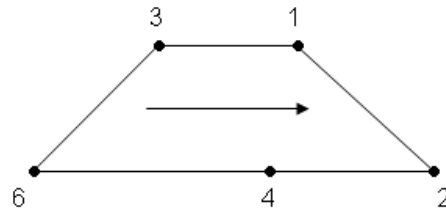

Figure 2.3.3: An example of a stability pattern for a six-legged walker with an arrow indicating the direction of locomotion and numbers indicating the positions of five out of six legs contributing to the pattern.

The stability margin, S_m , of a stability pattern is the minimum distance that the vertical projection of a walker's center of mass is from the edge of its stability pattern. Figure 2.3.4 shows the vertical projection of the center of mass of a six-legged walker on its support pattern. S_m for this configuration is the minimum of the distances d_1 , d_2 , and d_3 . As long as $S_m \geq 0$ for the entire locomotive cycle, the gait is statically stable.

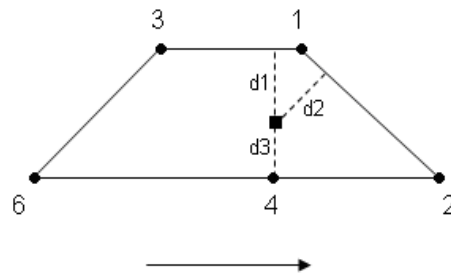

Figure 2.3.4: A support pattern of a six-legged walker with the vertical projection of the walker's center of mass indicated by the black square. S_m is the minimum of the distances d_1 , d_2 , and d_3 .

When analyzing the stability of a longitudinal $2n$ -legged walker, it is helpful to calculate the longitudinal stability margin, S_{long} . S_{long} is similar to S_m but it is the minimum distance of the vertical projection of the center of mass of the walker to the front or rear boundaries of the stability pattern. S_{long} is depicted in Figure 2.3.5; S_{long} is the minimum of d_1 and d_2 .

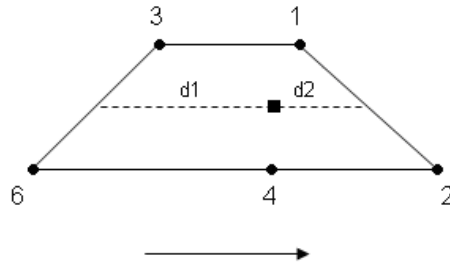

Figure 2.3.5: Support pattern of six-legged walker showing vertical projection of center of mass. S_{long} is the minimum of $d1$ and $d2$.

A gait is considered periodic if it can be broken up into identical locomotion cycles, that is, the locus of each leg always remains the same and returns to its original position at the end of each cycle. Only periodic gaits will be considered in this paper because the goal of this project is to design a walking mechanism that requires no external or internal control mechanisms; a non-periodic gait inherently requires a control mechanism of some sort.

A $2n$ -legged gait is considered regular if each of the pairs of legs has a relative phase shift of half a locomotion cycle. Often, regular gaits are both more efficient and more stable than non-regular gaits, but this is not always the case. In this paper I will explore both regular and non-regular gaits.

2.3.3 Graphical Methods for Gait Analysis

In this paper I will use two types of diagrams to illustrate the time evolution and stability of gaits: the gait diagram and the footfall diagram. Both diagrams give information about which legs are in the support phase and which are in the transfer phase for multiple time steps of the locomotive cycle. Both β_i and ϑ_i values can be determined from the diagrams by inspection.

A gait diagram is shown in Figure 2.3.6. The x-axis corresponds to time; in the case of Figure 2.3.6, time is broken up into 12 equal sections. Each of the legs of the walker is mapped across the y-axis. It is convenient to group together legs of a common side of the walker in the diagram so that stability can be determined more easily by inspection. Accordingly, Figure 2.3.6 shows legs 1, 3, and 5 adjacent to each other and legs 2, 4, and 6 adjacent to each other on the y-axis. The gray squares indicate that a leg is in the support phase and the white squares indicate that a leg is in the transfer phase. Thus, we can determine that $\beta = 3/4$ for all the legs of the walker diagrammed in Figure 2.3.6 because each of the legs has nine out of twelve squares colored grey.

It is also straightforward to determine the ϑ_i values of each of the legs of the walker from the gait diagram. As stated earlier, it is customary to assign $\vartheta_1 = 0$. Then ϑ_i can be determined for the rest of the legs by dividing the x-coordinate of the white to grey transition for each leg by 12. For example placing event occurs at time interval 10 for leg 3. Then $\vartheta_3 = 10/12$ or $5/6$.

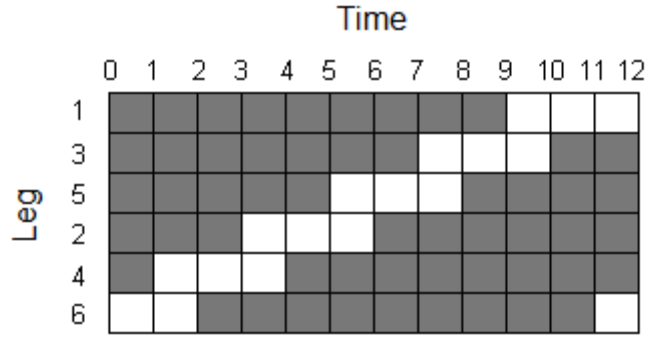

Figure 2.3.6: A gait diagram for a six-legged walker with $\beta = \frac{3}{4}$ for all legs. A grayed out square represents a leg in the support phase and a white square represents a leg in the transfer phase.

Figure 2.3.7 is a series of footfall diagrams of a gait identical to the one depicted in Figure 2.3.6. β_i and ϕ_i values can also be determined from this diagram, although, it is much more convenient to use the gait diagram for this analysis. A footfall diagram is more useful for determining the stability of a gait pattern through an entire locomotive cycle. In the figure, each of the legs of a walker is represented with a circle. The diagram at the top left has the leg numbers labeled, though this information can be determined by noticing the arrows below each diagram indicating the direction of locomotion. It is customary to draw footfall diagrams so that the direction of locomotion is from left to right, so the arrows will be omitted for the remainder of this paper. The numbers above each diagram correspond to the same time steps indicated in Figure 2.3.6. A grayed out circle represents a leg in the support phase, and a white circle represents a leg in the transfer phase.

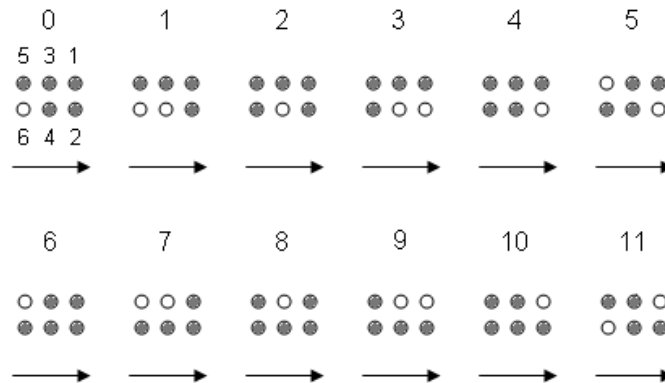

Figure 2.3.7: A series of footfall diagrams depicting the same six-legged gait as Figure 2.3.6. The numbers at the top of each diagram indicate the same time divisions as in Figure 2.3.6. The arrows at the bottom of each diagram indicate the direction of locomotion. A grayed out circle represents a leg in the support phase and a white circle represents a leg in the transfer phase.

A polygon can be drawn between the supporting legs of each footfall diagram as illustrated in Figure 2.3.8. This polygon gives a general sense of the stability pattern for each of twelve time steps in one complete locomotion cycle. We cannot determine exact stability patterns from footfall diagrams because they do not convey the relative movement between the legs of a walker, nor do they indicate the position of the center of mass.



Figure 2.3.8: Approximate stability pattern generated from footfall diagram of six-legged walker.

2.3.4 Wave Gaits

The wave gait has been proven to maximize S_{long} for all regular, periodic $2n$ -legged longitudinal walkers (Sun, 1974). In fact, it is the gait employed by many $2n$ -legged animals including most insects. It defines a set of ϕ_i values that can be adjusted for a wide range of beta values. The wave gait is generalized for a $2n$ -legged walker in the following equations:

$$\begin{aligned} \phi_{(2m+1)} &= F(m \cdot \beta) \\ \phi_{2(m+1)} &= F(m \cdot \beta + 1/2) = \phi_{(2m+1)} + 1/2 \quad \text{for } m = 0, 1, 2, \dots (n-1) \text{ and } 3/(2n) \leq \beta < 1 \end{aligned}$$

Where $F(x)$ takes the fractional part of x (for example, $F(5/3) = 2/3$), and m is defined as before as the number of legs directly in front of a given leg _{i} (the front legs have $m = 0$). Gait diagrams for wave gaits of various β values with their corresponding footfall diagrams are shown in Figure 2.3.9.

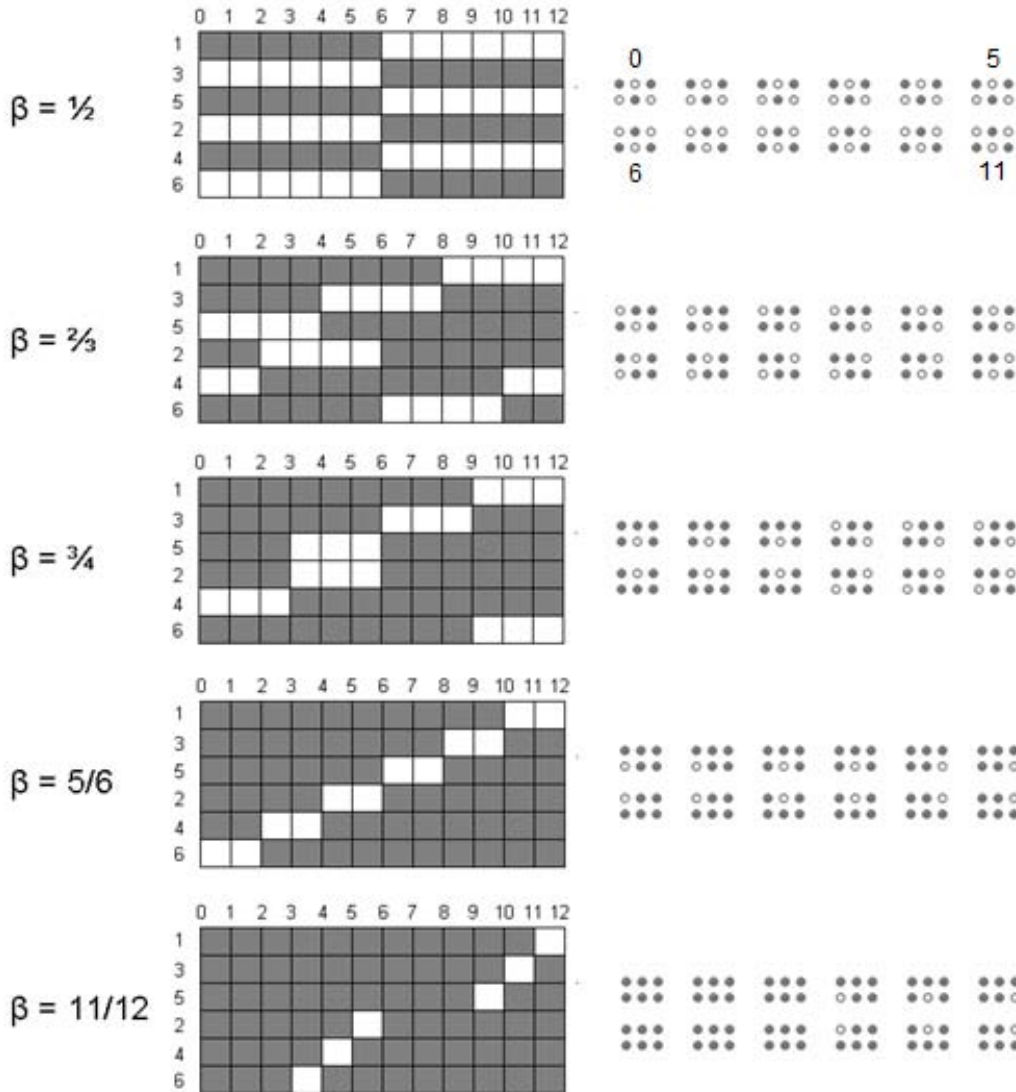

Figure 2.3.9: Gait and footfall diagrams of a wave gait for six-legged longitudinal walker showing five values of beta mapped out across twelve time steps. The top footfall diagram is numbered in order of time for clarification. It is interesting to note that every stability pattern of one locomotive cycle is accompanied by a longitudinally mirrored pattern exactly one half cycle away (the pattern directly above or below it)³.

2.3.5 Equal Phase Gaits

Equal phase gaits attempt to increase the energetic efficiency of a walker by evenly distributing lifting and placing events throughout the locomotive cycle so that acceleration of the central crank is minimized. Equal phase gaits can be divided into two categories: half cycle equal phase and full cycle equal phase. Both gaits are regular.

Half cycle equal phase gaits are constructed by equally distributing the placing events of the feet on one side of the walker over a span of half of the locomotive cycle. Each pair of legs has a phase difference of half a cycle so the placing events of the legs

on the other side of the walker are equally distributed over the remaining portion of the locomotive cycle. The half cycle equal phase gait of a $2n$ -legged walker is expressed generally as:

$$\begin{aligned} \phi_{(2m+1)} &= 1 - m/(2n) \\ \phi_{2(m+1)} &= 1/2 - m/(2n) = \phi_{(2m+1)} + 1/2 \end{aligned} \quad \text{for } m = 0, 1, 2 \dots (n-1)$$

Full cycle equal phase gaits are constructed by equally distributing the placing events of the feet on one side of the walker over a full locomotive cycle. Again, the remaining legs are offset by half a phase from their pairs so that their placing events are also equally distributed throughout the locomotive cycle. This is expressed for a $2n$ -legged walker generally as:

$$\begin{aligned} \phi_{(2m+1)} &= 1 - m/n \\ \phi_{2(m+1)} &= 1/2 - m/n = \phi_{(2m+1)} + 1/2 \end{aligned} \quad \text{for } m = 0, 1, 2 \dots (n-1)$$

Full cycle and half cycle equal phase gait diagrams are shown in Figure 2.3.10 for various beta values. By comparing these diagrams with the wave diagrams from the previous section, it is apparent that wave gaits and equal phase gaits are not mutually exclusive. In fact, the full cycle equal phase gait for beta = $2/3$ and the half cycle equal phase gait for beta = $5/6$ are identical to their corresponding wave gaits.

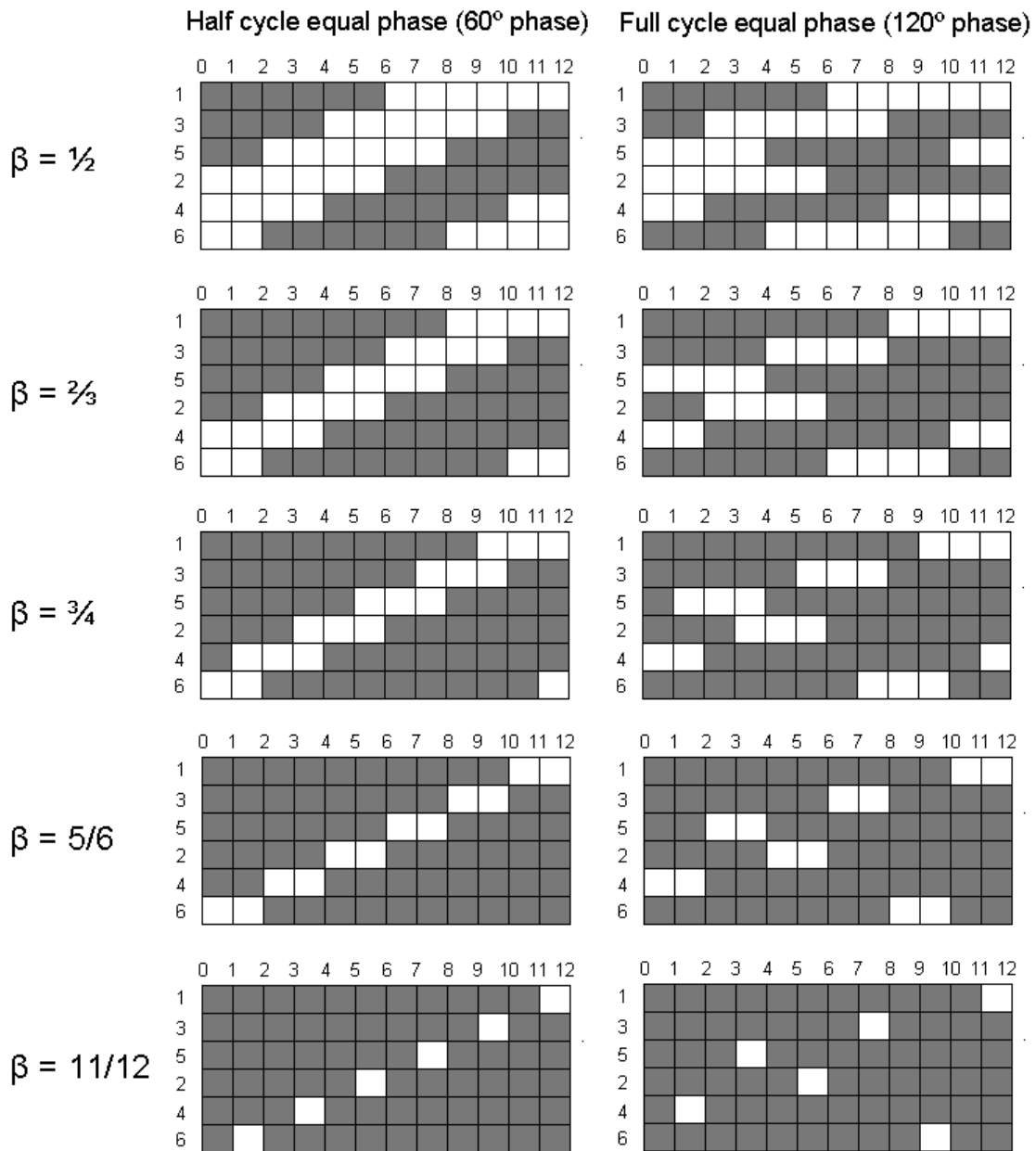

Figure 2.3.10: Gait diagrams for half and full cycle equal phase gaits of a six-legged longitudinal walker for five values of beta. Note that the half cycle equal phase gait with beta = 5/6 and the full cycle equal phase gait with beta = 2/3 are identical to wave gaits of corresponding beta values.

2.3.6 2n-Legged Lateral Walkers

My walking machine will be slightly different than the machine described by the gait diagrams in the previous section because of the necessity that all the legs are coupled to one central crank axis. The diagrams above describe a longitudinal walker as shown in the picture on the right of Figure 2.3.11. I will be building a lateral walker (also shown in

Figure 2.3.11). Although the geometries are slightly different, the same basic gait principals apply to both designs. I will discuss this in more detail in Chapter 6.

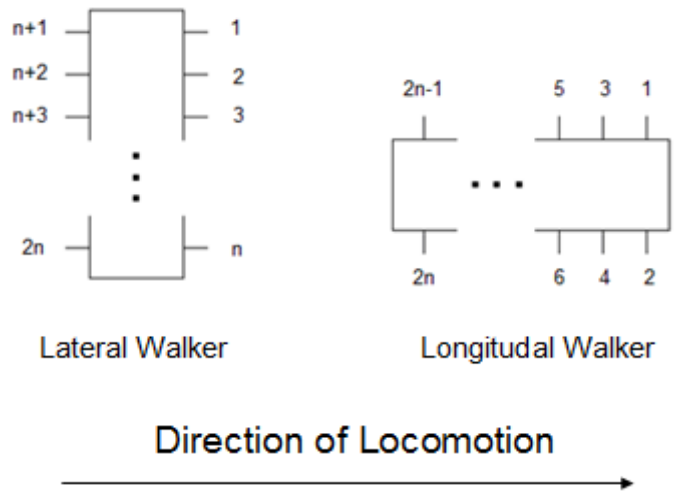

Figure 2.3.11: Diagram of lateral and longitudinal 2n legged walkers showing the direction of locomotion. Although the leg numbering system is different between the two walkers, both designate the front left leg to be leg 1. Thus, the phase relationship ϕ_i is still defined as the relative phase of the leg i relative to leg one in a locomotive cycle.

Chapter 3: Survey of Walking Mechanisms and Analysis in Mathematica

3.1 Introduction

In this chapter I will describe two existing crank-based walking linkages and assess their energy efficiency and the quality of their loci both quantitatively and qualitatively. I will begin with the Hrones-Nelson four bar linkage and continue on to the more complex Theo Jansen mechanism. I have chosen to compare these two linkages because they are both comprised solely of rigid triangular bodies attached to four-bar linkages. As demonstrated in Figure 3.1.1 when two hinges of a three-bar linkage are fixed, then the third hinge must also be fixed. In other words, a triangle with sides of fixed lengths must also have angles of fixed lengths. However, when two hinges of a four bar linkage are fixed, the other two hinges are free to move in one dimension.

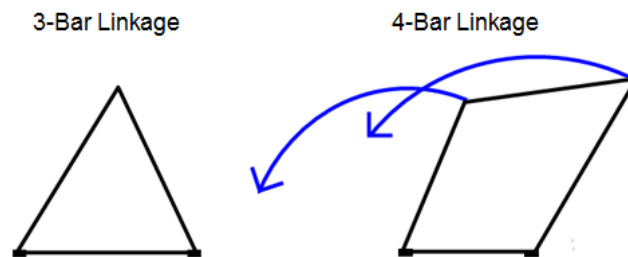

Figure 3.1.1: Three bar and four bar linkages with two fixed hinges demonstrating movement of remaining hinges.

The Hrones-Nelson and Theo Jansen mechanisms are shown below demonstrate the similarity of their designs. The Hrones-Nelson mechanism is comprised of one triangular structure attached to a four bar linkage whose movement is driven directly by a crank. The Theo Jansen mechanism is comprised of two four bar linkages attached to each other in series with only one of the four bar linkages driven directly by the crank; the four bar linkages share one hinge in common and are separated by a rigid triangular structure on one side. Additionally, another rigid triangle is attached to the linkage to create the “foot” of the mechanism, as is the case in the Hrones-Nelson model.

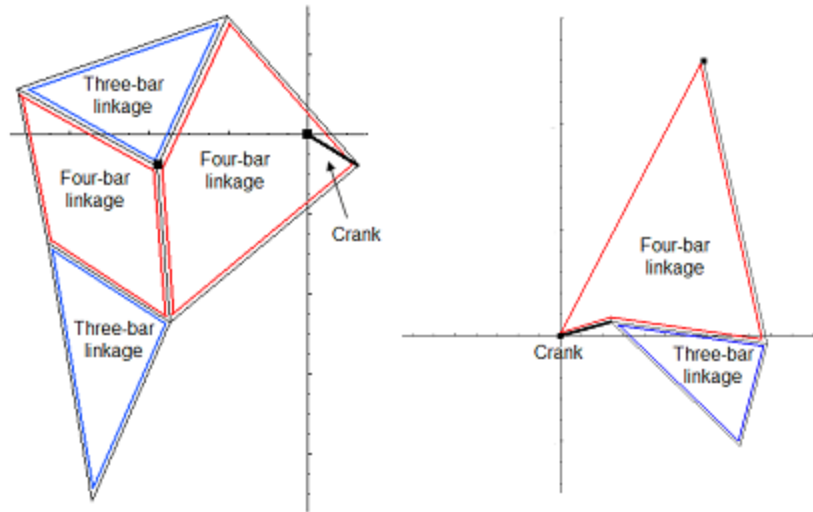

Figure 3.1.2: Theo Jansen (left) and Hrones-Nelson (right) Mechanisms with four bar linkages highlighted in red and three bar linkages highlighted in blue to show similarity of design.

In this analysis I used Wolfram Mathematica to solve for and plot the center of mass, position, velocity, acceleration, and kinetic and potential energies of the elements of the linkage. I used this information to determine the potential and kinetic energy of the linkage throughout the locomotive cycle and evaluate the loci of each mechanism for quality of locus. All Mathematica code is located in Appendix A for reference.

3.2 Hrones-Nelson Mechanism

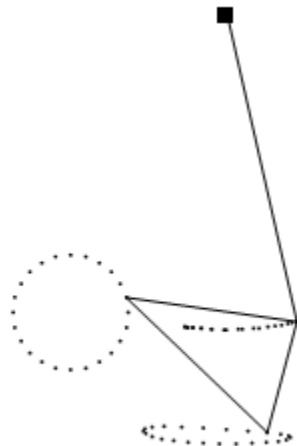

Figure 3.2.1: The Hrones-Nelson mechanism with movement of each of its hinges plotted for 24 equally spaced time steps. Black square indicates a fixed hinge.

Figure 3.2.1 shows one version of the Hrones-Nelson mechanism tracing out a locus. Loci of slightly different shapes can be achieved by changing the linkage lengths of the mechanism, especially the position of the fixed hinge. The locus that is currently shown has a short step height and its support phase is considerably rounded instead of flat and straight. All of the loci of the Hrones-Nelson model share a teardrop shape; they do not possess symmetry across a vertical axis. In section 3.3.3, I will show how the Theo Jansen mechanism simplifies to a model that is identical to a Hrones-Nelson mechanism.

3.3 Theo Jansen Mechanism

3.3.1 Introduction

The optimized Theo Jansen mechanism and numbering system are shown in the figure below. The linkage lengths were taken directly from Theo Jansen's book *The Great Pretender*.¹ The black squares at points 0 and 3 in the diagram indicate the location of fixed points in the linkage. Point 0 is the crank axis and maintains a constant relative position to point 3 throughout the locomotive cycle. In this analysis I will always fix point 0 at the origin and point three at $(-38, -7.8)$.

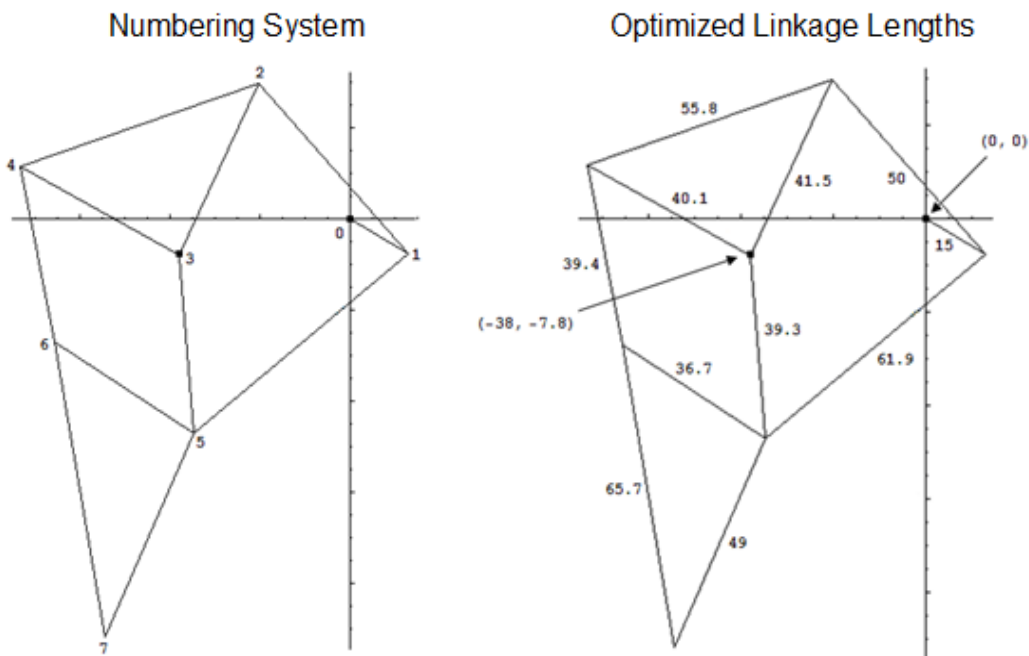

Figure 3.3.1: Diagram of Theo Jansen mechanism showing numbering system and optimized linkage lengths to be used later in this analysis. In this paper hinge 1 may be called “the crank” and hinge seven may be called “the foot.” Hinges 0 and 3 have fixed positions relative to each other for the entire locomotive cycle; the convention in this analysis will be fix hinge 0 at the origin and hinge 3 at $(-38, -7.8)$.

3.3.2 Position, Velocity, and Acceleration

Figure 3.3.2 shows the position of hinges 1, 2, 4, 5, 6, and 7 for 48 equally spaced time intervals spanning an entire locomotive cycle (hinges 0 and 3 were omitted because they have fixed positions in this reference frame). Since I have used equally spaced time steps to plot the position of the hinges, you can identify periods of relatively high and relatively low velocities by noticing the spacing between adjacent points in the plot. By inspection, you can see that the angular velocity of the crank is constant; this will be the convention throughout this analysis. You can also see in the “Position of foot” plot that the support phase of the Theo Jansen mechanism has near constant velocity; this will be evaluated further later on in this analysis.

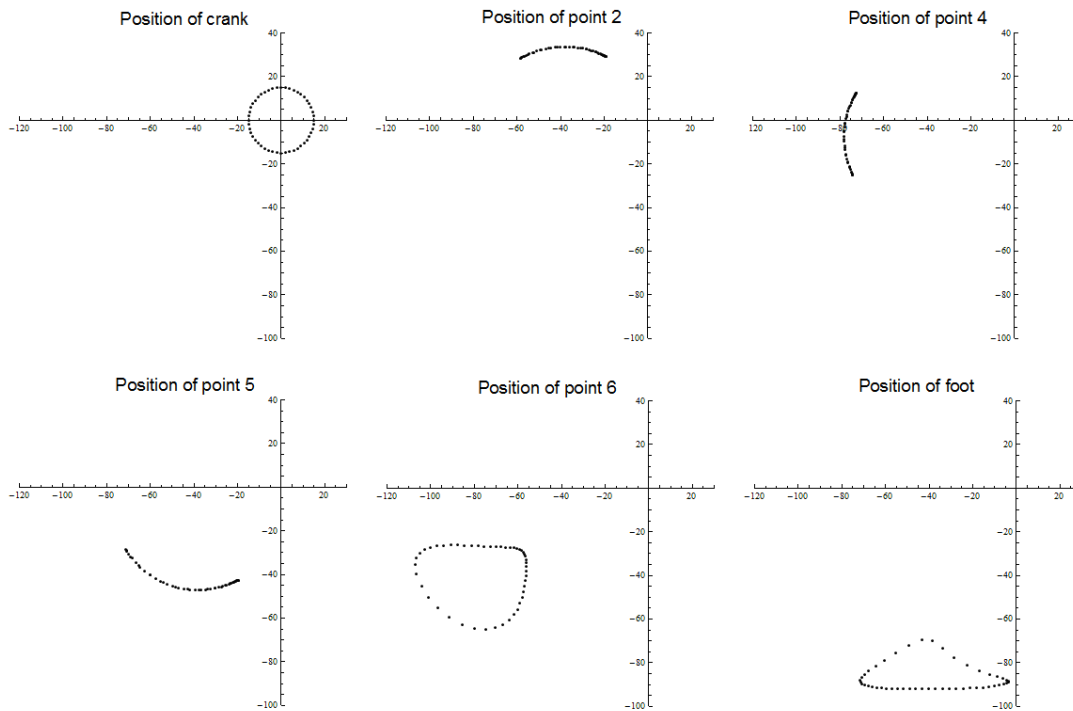

Figure 3.3.2: Position of moving hinges of Theo Jansen mechanism (hinges zero and three are stationary). All hinges are plotted in 48 equally spaced time steps spanning one locomotive cycle. Numbering system is indicated in Figure 3.3.1.

The following figure shows the results of the previous plots with an image of the full Theo Jansen mechanism at an arbitrary time step plotted on top.

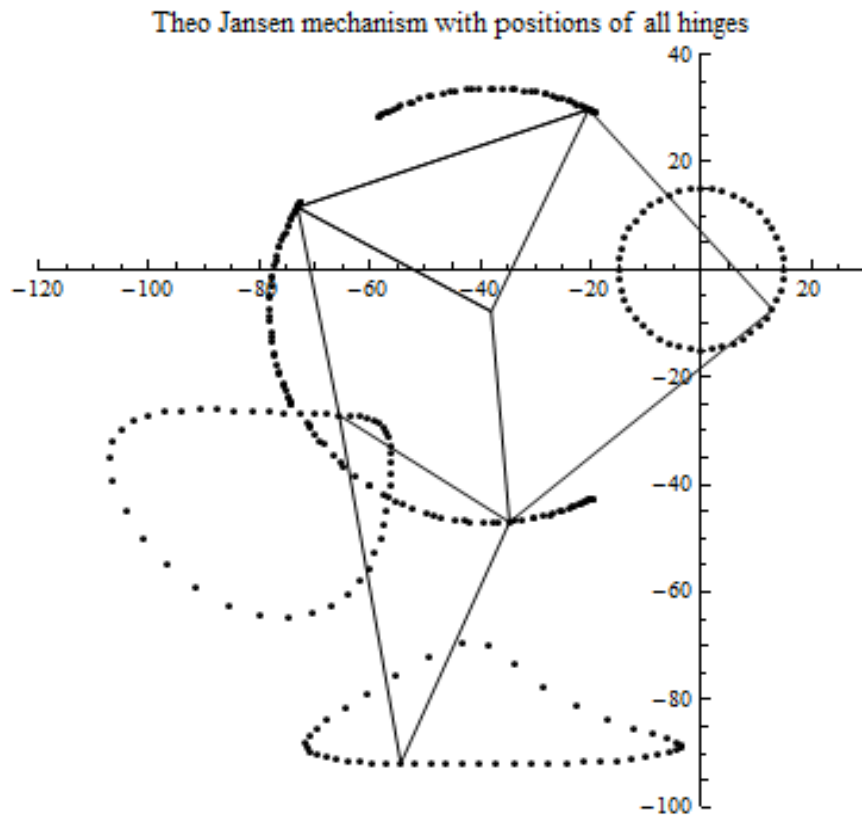

Figure 3.3.3: Theo Jansen mechanism with position of all moving hinges during a complete locomotive cycle shown. The positions of all hinges are plotted for 48 evenly spaced time steps.

Figures 3.3.4 and 3.3.5 demonstrate the time evolution of the Theo Jansen mechanism in one locomotive cycle. Figure 3.3.4 shows twelve steps of the mechanism spanning one complete cycle in sequential order. Figure 3.3.5 superimposes 24 plots of the Theo Jansen linkage taken at even time steps during one locomotive cycle.

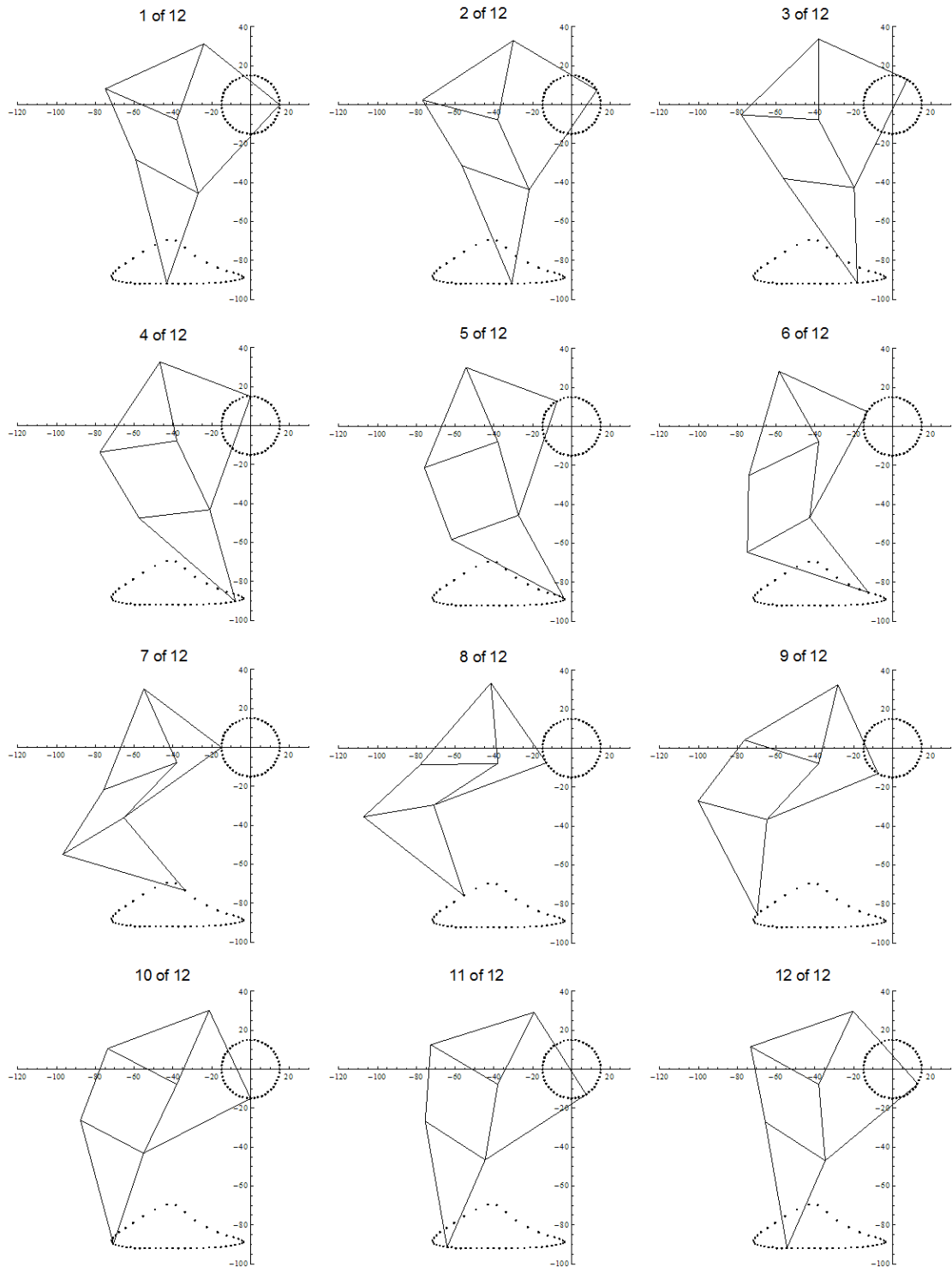

Figure 3.3.4: Twelve equally spaced time steps of Theo Jansen mechanism in sequential order to demonstrate the time evolution of one locomotive cycle.

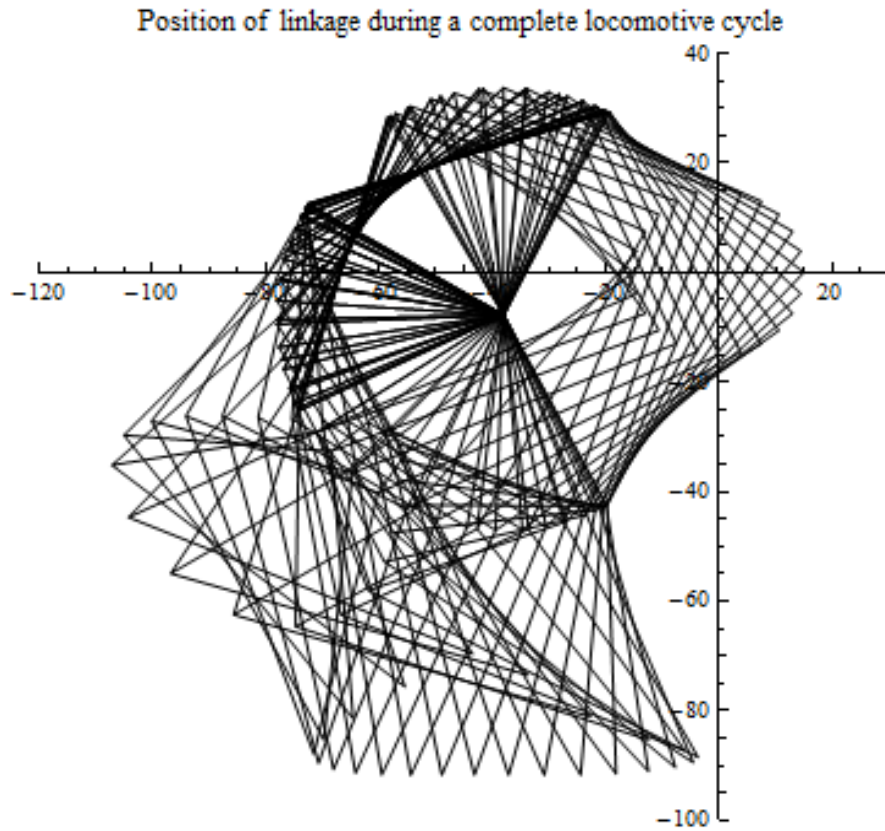

Figure 3.3.5: Twenty four equally spaced time steps of Theo Jansen mechanism spanning one complete locomotive cycle superimposed.

3.3.3 Understanding the Movement of the Theo Jansen Linkage

By making a series of approximations about the movement of each hinge in the Theo Jansen mechanism, it is possible to understand the mechanism's movement. First considered the numbering system I have introduced in section 3.3.1, reproduced below:

Numbering System

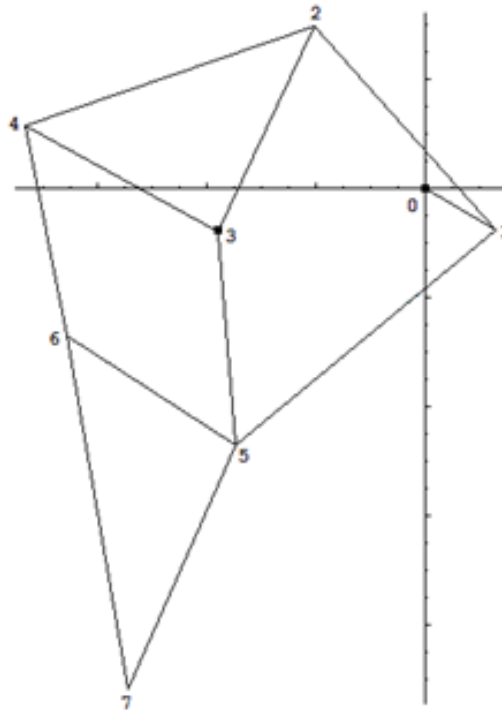

Figure 3.3.6: Theo Jansen mechanism with numbering system indicated.

Since hinges 2 and 5 are both directly attached to fixed point 3, they must move along the perimeter of a circle centered around point 3 (Figure 3.3.7 A). The radii of these circles are large compared to the distance that the hinges move, so we can approximate this movement as a straight line (Figure 3.3.7 B). The rotation of the crank causes hinges 2 and 5 to move in the x direction with an approximately constant phase difference of $\frac{1}{2}\pi$. Then, hinge 2 moves with $\cos(\theta)$ and hinge 5 moves with $\sin(\theta)$ in the x direction (Figure 3.3.7 C). Similarly, we can approximate the movement of hinge 4 as a straight line. The angle from hinge 2 to 3 to 4 is approximately $\frac{1}{2}\pi$, so the movement of hinge 4 can be approximated as $y = \cos(\theta)$ (Figure 3.3.7 D). Hinge 6 moves with hinge 4 in the y direction and hinge 5 in the x direction. As shown in Figure 3.3.7 E, hinge 6 traces out an approximately circular path in the clockwise direction. By considering only hinges 3,5,6 and 7, we are left with a mechanism which approximates to the Hrones-Nelson mechanism (Figure 3.3.7 F). Compare this approximation with the actual movement of the mechanism reproduced in Figure 3.3.7 G.

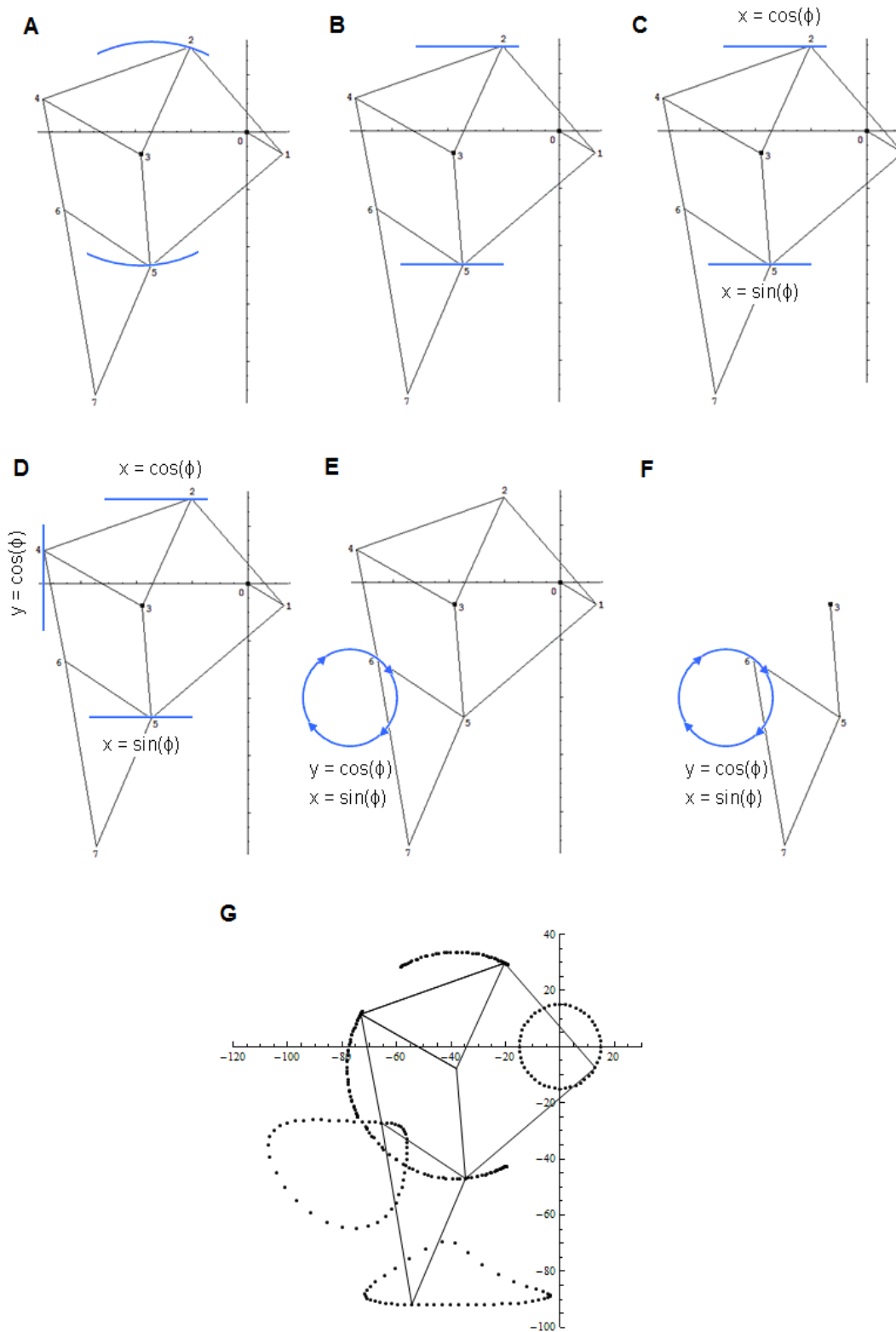

Figure 3.3.7: Approximations of Theo Jansen mechanism movement to help understand the linkage mechanics shown alongside actual position plot (G). More detailed description is given in the paragraph above.

3.3.4 Quality of Locus

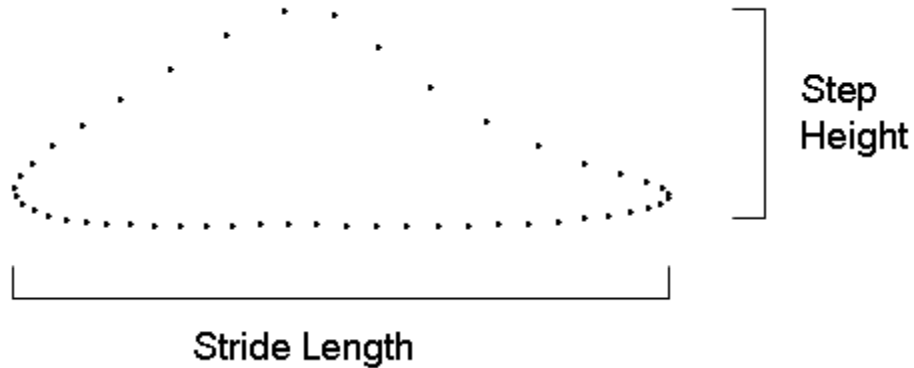

Figure 3.3.8: Locus of Theo Jansen Mechanism with stride length and step height indicated.

Figure 3.3.8 shows the locus of the Theo Jansen mechanism generated from the Mathematica model. The stride length can be determined by finding the difference between the minimum and maximum x coordinates for an entire locomotive cycle, and the step height can be found by analyzing the y coordinates similarly. That information is given in Table 3.3.1. These measurements will be normalized so that the stride length equals one when I compare loci in section 6.6.

Table 3.3.1: Analysis of Theo Jansen Locus (not normalized)

Stride Length	67.9
Step Height	22.4

The support phase of the locus must also be assessed for straightness and constant velocity in order to determine its suitability for a multi-legged walking machine. Figure 3.3.9 shows the support phase of the Theo Jansen mechanism in blue. The support phase begins when the crank is at a position of 4.8 radians and ends when the crank is at 1.7 radians as shown in Figure 3.3.10. Straightness is determined from the consistency of the height of the foot during the support phase.

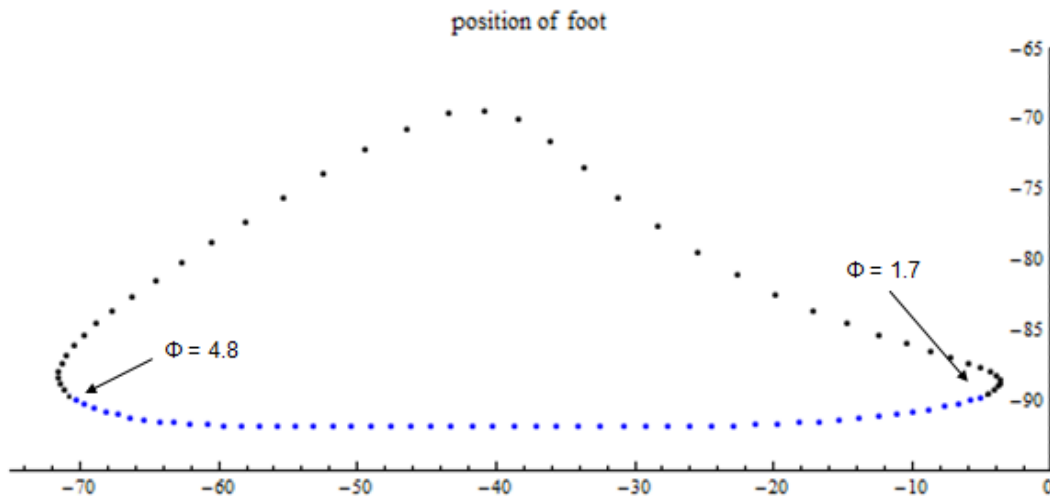

Figure 3.3.9: A closer view of the locus from figure 3.3.8. This diagram shows 98 evenly spaced time steps spanning one locomotive cycle. x and y axes have the same scale in this diagram. Support phase is shown in blue with angle of crank at the beginning and end of support phase indicated (also see Figure 3.3.10).

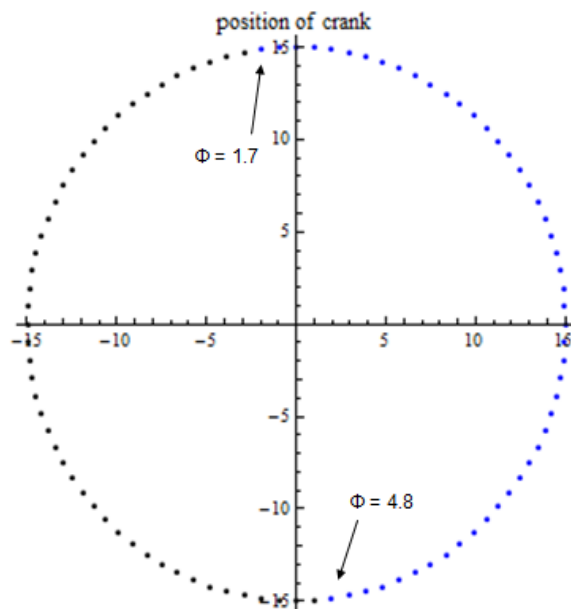

Figure 3.3.10: Position of crank for one locomotive cycle with duration of support phase shown in blue. Start of support phase is indicated at $\phi = 4.8$ rad and end is indicated at $\phi = 1.7$ rad.

By looking closely at the support phase of the Theo Jansen mechanism (Figure 3.3.11), you can see that there is a slight lift at the center. Although this is not ideal, this small deviations only represent about 2% of the total step height and may therefore be considered negligible compared to the scale of fabrication errors (see section 7.3). In

designing my own mechanism, I will aim to minimize y axis deviations from the lowest part of the stride.

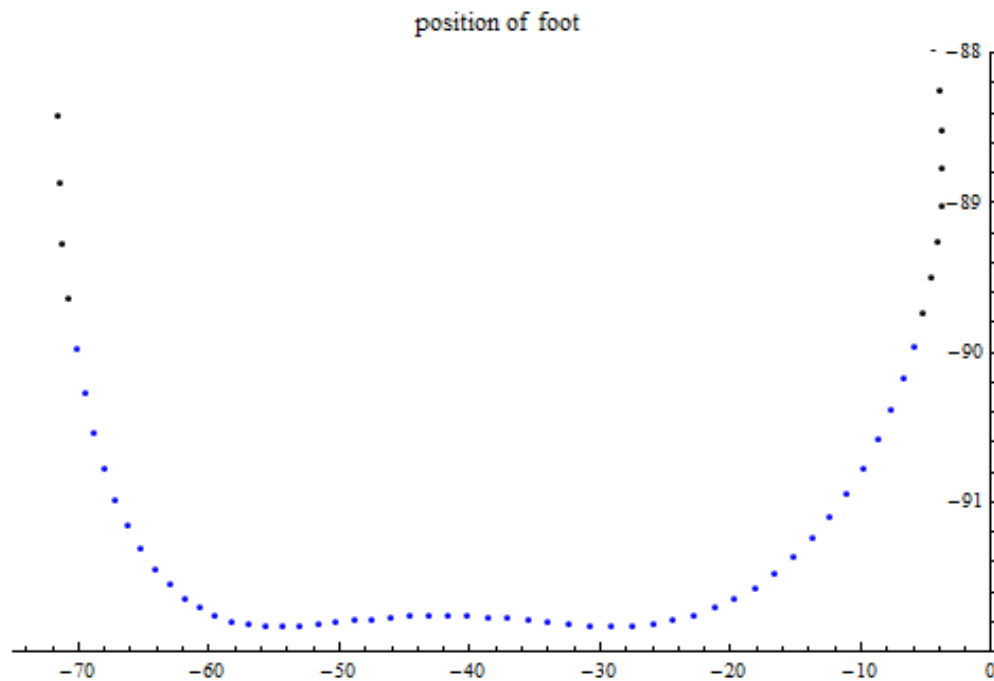

Figure 3.3.11: A plot of the locus which has been magnified to inspect the straightness of the support phase (shown in blue). As in Figure 3.3.9, this locus is plotted over 96 time steps spanning one locomotive cycle (although some time steps from Figure 3.3.9 exceed the range of these axes). Notice that the scale of the y axis has changed from Figure 3.3.9, so the x and y axes no longer have the same scale. Also notice the subtle curve of the support phase.

An optimal support phase has a constant x velocity. We can look at the x velocity (Figure 3.3.12) and x acceleration (Figure 3.3.13) curves for the locomotive cycle to assess the consistency of the velocity of the support phase. Since I have picked an arbitrary coordinate system to plot this linkage, the exact values of position, velocity, and acceleration in these plots are not meaningful, though their relative magnitudes are.

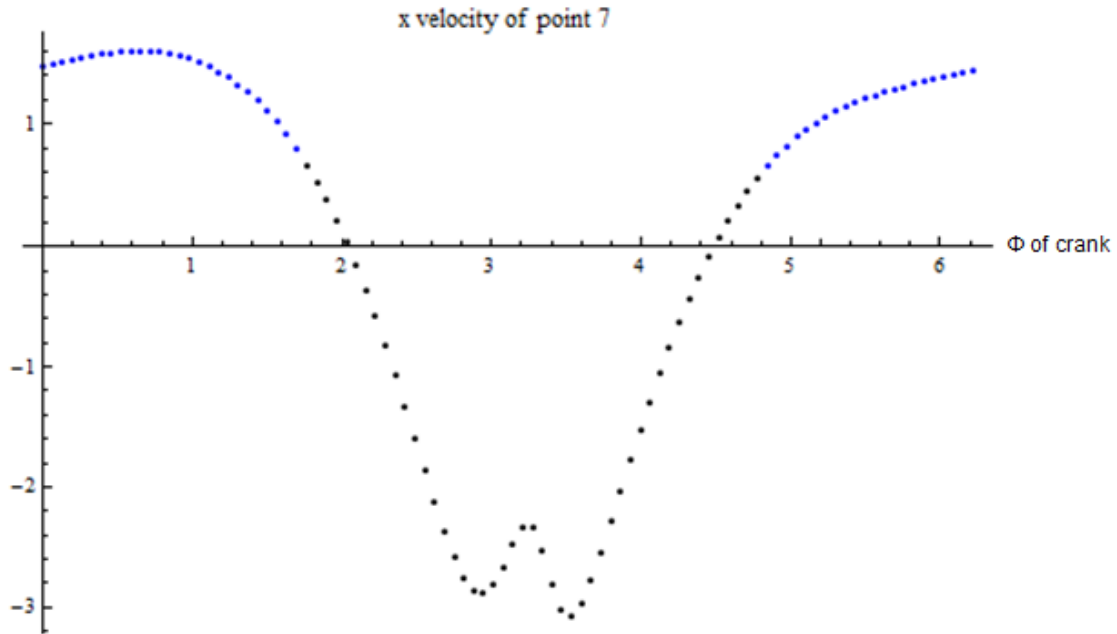

Figure 3.3.12: x component of velocity of locus for an entire locomotive cycle shows a slight increase in x velocity of support phase as θ increases. Support phase is shown in blue. X-axis is θ position of crank.

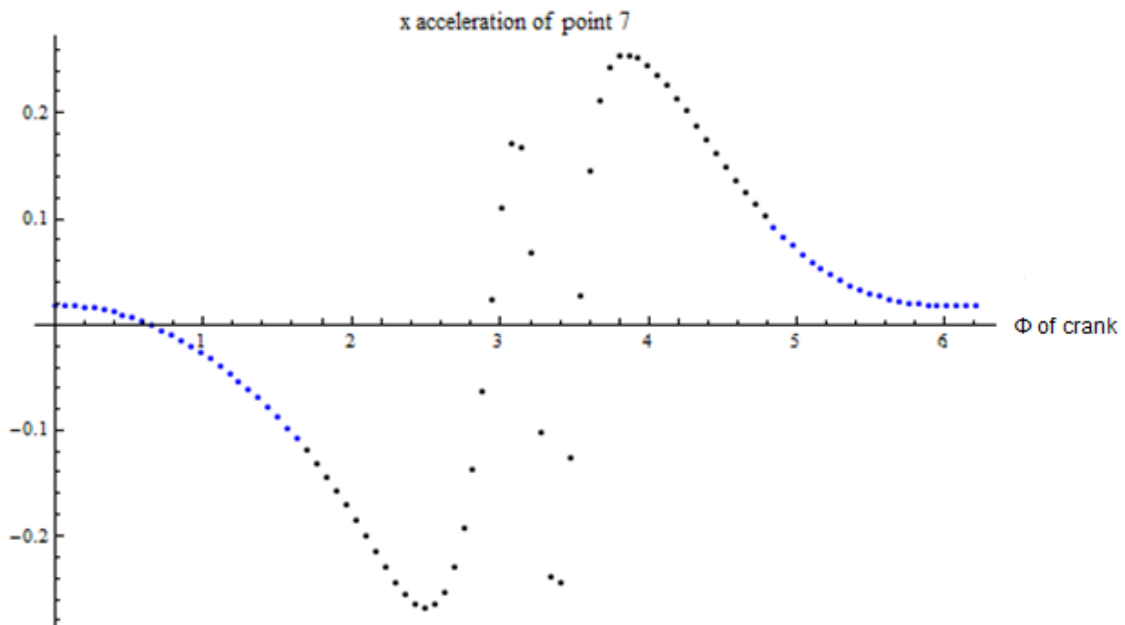

Figure 3.3.13: Acceleration in direction of locus with support phase shown in blue. Majority of support phase has acceleration greater than zero. X-axis is θ position of crank.

As shown in Figures 3.3.12 and 3.3.13, there is a slight acceleration during the support phase of the Theo Jansen mechanism. This acceleration can be quantified by

calculating the standard deviation of the x acceleration from zero for the duration of the support phase. These results are summarized in Table 3.3.2. The variation in x velocity is much more significant than the variation in y position; the standard deviation of the x velocity is equal to about 15% of the average x velocity. In my design, I will aim to lower this value significantly.

Table 3.3.2: Analysis of Theo Jansen Support Phase over 96 cycle divisions (not normalized)

	Y position	X velocity (distance per cycle division)	X acceleration (distance per squared cycle division)
Minimum	-91.8	-----	-----
Mean	-91.5	1.3	0.009
Standard Deviation	0.5	0.2	0.04 (deviation from zero)

3.3.5 Center of Mass

By assuming that the components of the linkage have a constant density, it is a straightforward exercise to determine the center of mass throughout the locomotive cycle. If we assume that the mass of each rigid body in the linkage is equal to its length times a constant, then the center of mass of each link will always be located at its center. That is:

$$\begin{aligned} \text{If: } & \text{Mass} = (\text{constant}) * \text{Length} \\ \text{Then: } & \text{x coordinate of center of mass} = \frac{1}{2} (x_1 + x_2) \\ & \text{y coordinate of center of mass} = \frac{1}{2} (y_1 + y_2) \end{aligned}$$

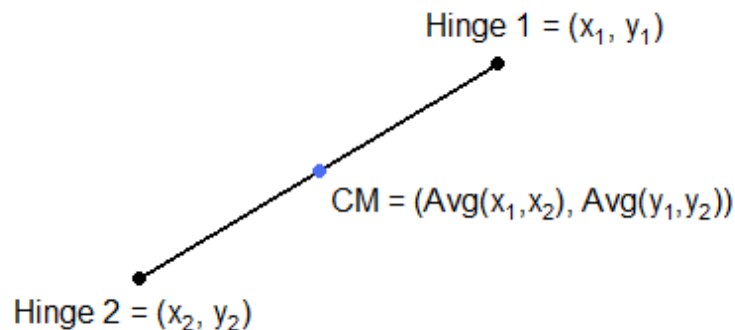

Figure 3.3.14: Determination of the position of the center of mass of a rigid body of uniform density. The center of mass is indicated by a blue dot and is located halfway between hinge one and hinge two.

Figure 3.3.15 shows the position of all eleven bodies of the Theo Jansen mechanism for a locomotive cycle with the position of the center of mass indicated in blue. Notice that, as I have described above, each center of mass falls at the center of a black line representing a rigid body at a given time step. The last plot in Figure 3.3.15 shows the complete Theo Jansen linkage with all the contributing centers of mass plotted on top.

The position of the total center of mass is calculated from the eleven contributing centers of mass according to the following relationship:

$$\text{Position CM}_{\text{total}} = \Sigma (\text{position CM}_{\text{contributing}}) / \Sigma (\text{Mass}_{\text{contributing}})$$

The position of the total center of mass is plotted on top of a diagram of the Theo Jansen mechanism for twenty four time steps in Figure 3.3.16.

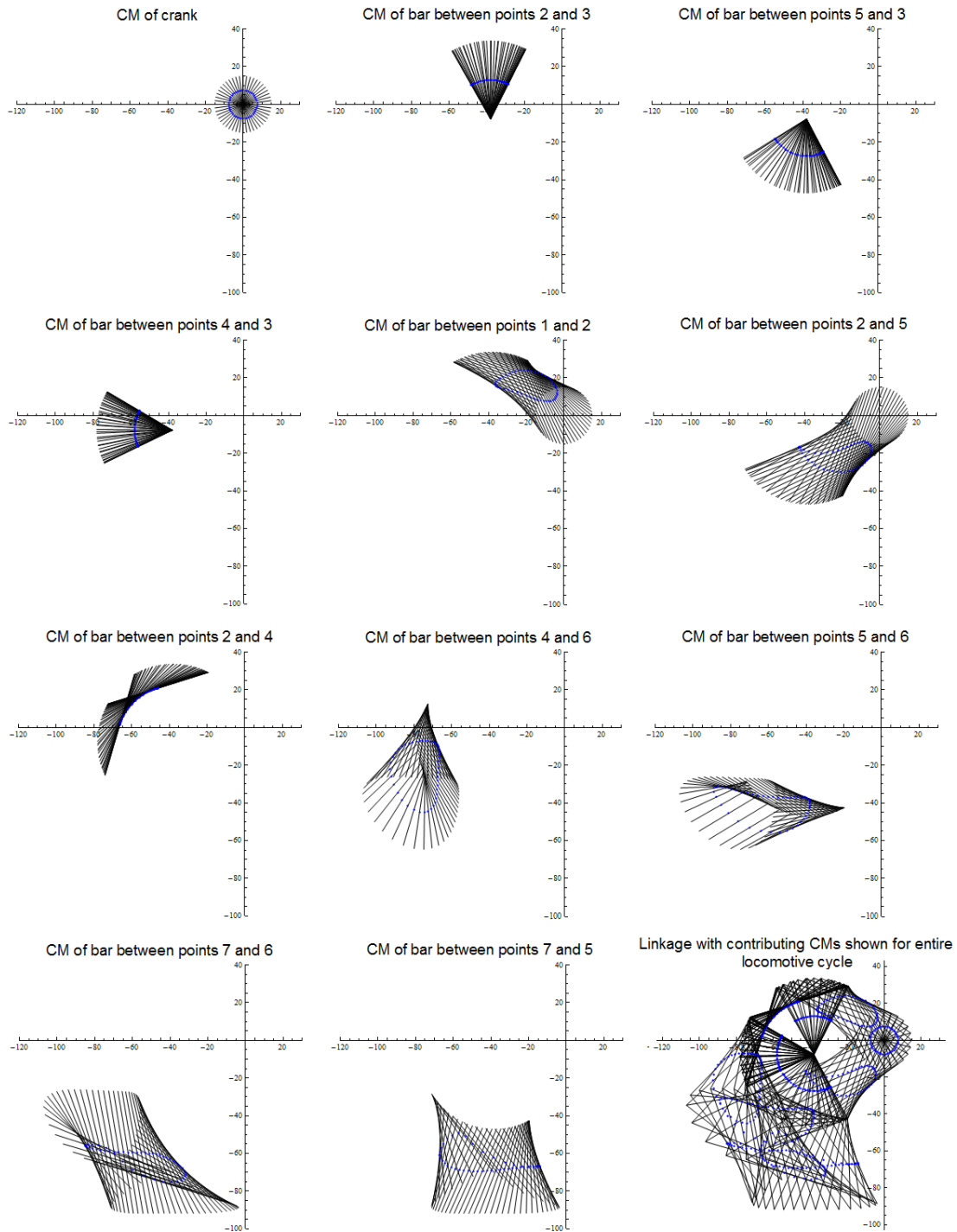

Figure 3.3.15: Position of all eleven rigid bodies of Theo Jansen mechanism plotted for 48 equally spaced time steps with center of mass indicated in blue. The last diagram shows the entire linkage with all eleven contributing center of masses plotted over 24 time steps.

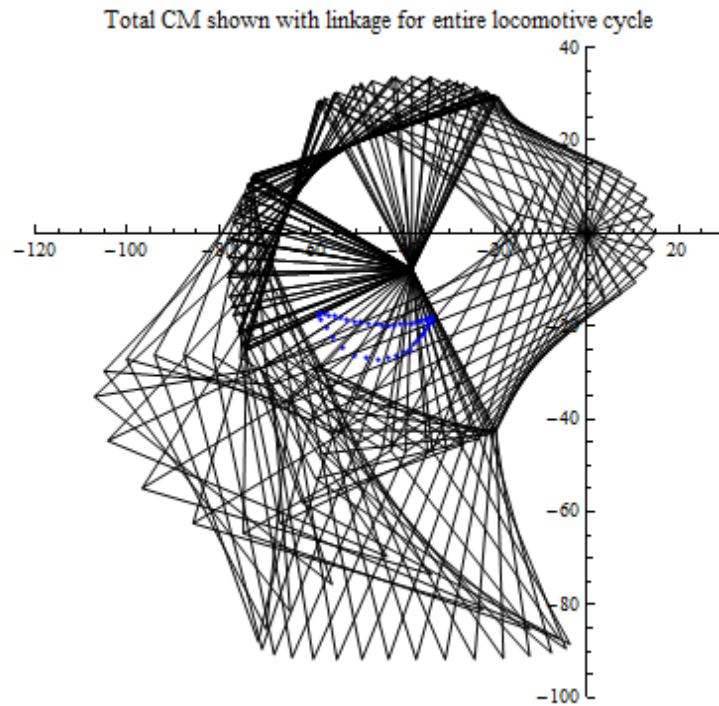

Figure 3.3.16: Diagram of twenty four time steps of Theo Jansen mechanism with the position of the total center of mass indicated in blue.

3.3.6 Analysis of a Linkage Pair

All of the Theo Jansen legs are mirrored by an identical pair, which is attached to the crank (point 1) at the same position. The time evolution of a pair of legs is shown below. Notice how both legs trace their respective locus in the counterclockwise direction, but that the loci are mirror images of each other.

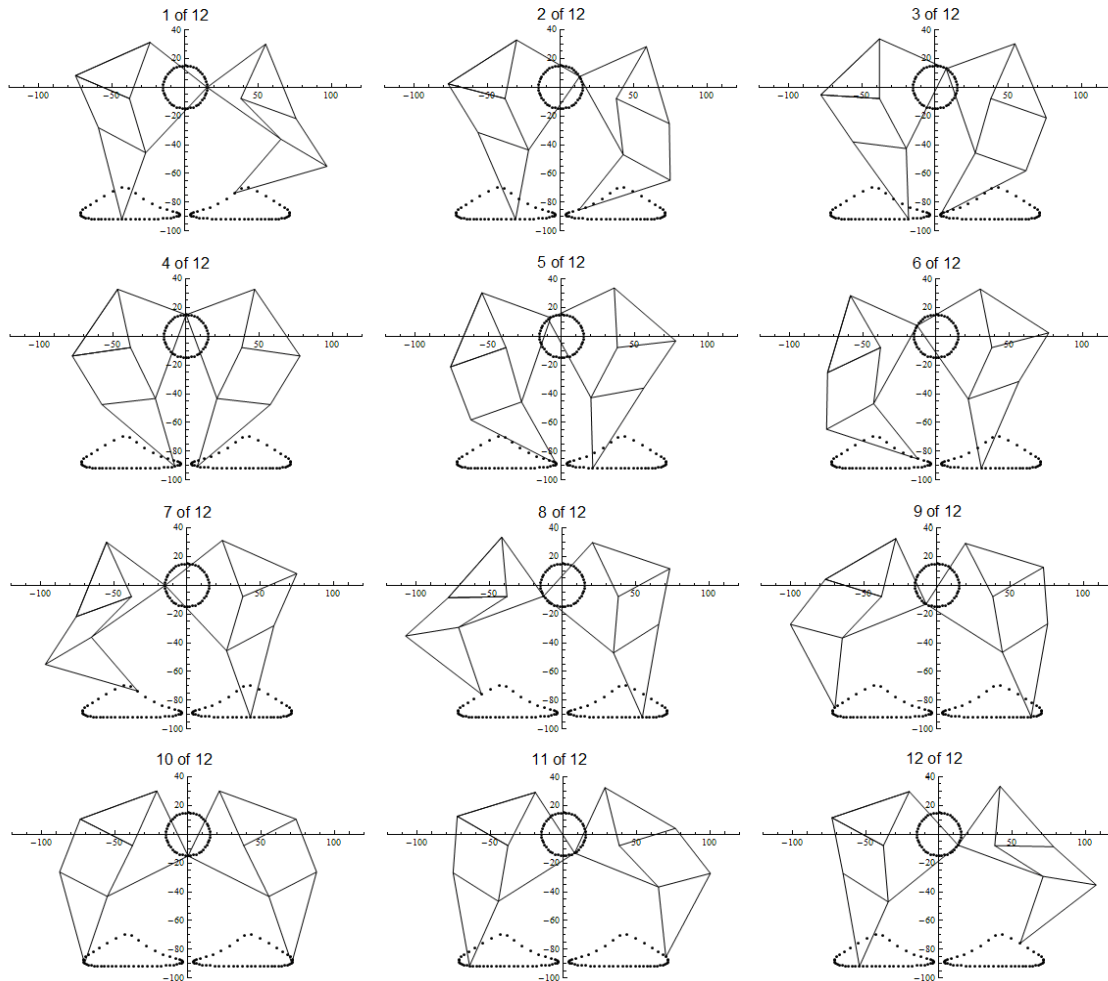

Figure 3.3.17: Twelve equally spaced time steps of a pair of Theo Jansen legs demonstrating the time evolution of one locomotive cycle.

When analyzing the movement of the center of mass during a locomotive cycle, it is important to consider the entire leg pair. Ideally, the movement of one leg's center of mass will cancel out the movement of its pair's center of mass. Since the locus of the Theo Jansen mechanism is not symmetrical about a vertical or horizontal axis, the center of mass of the leg pairs will not completely cancel out. Figure 3.3.18 shows the x and y position of the center of mass of the leg pair and Figure 3.3.19 shows a plot of the total cm.

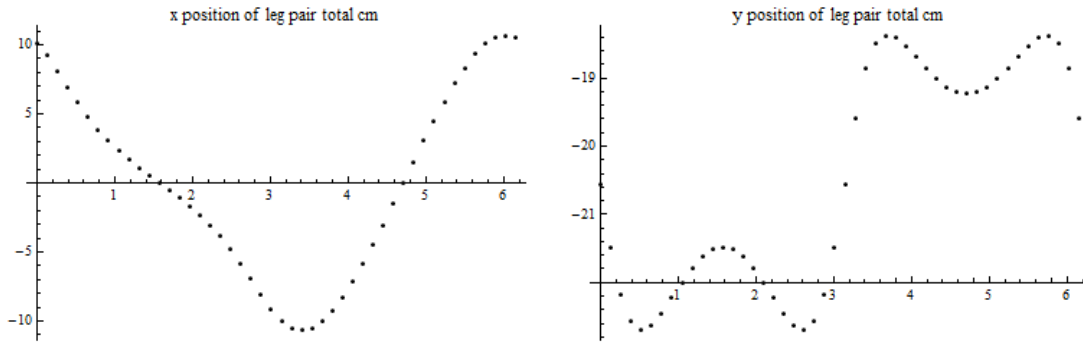

Figure 3.3.18: x and y positions of total cm of a Theo Jansen leg pair plotted against position of θ on crank.

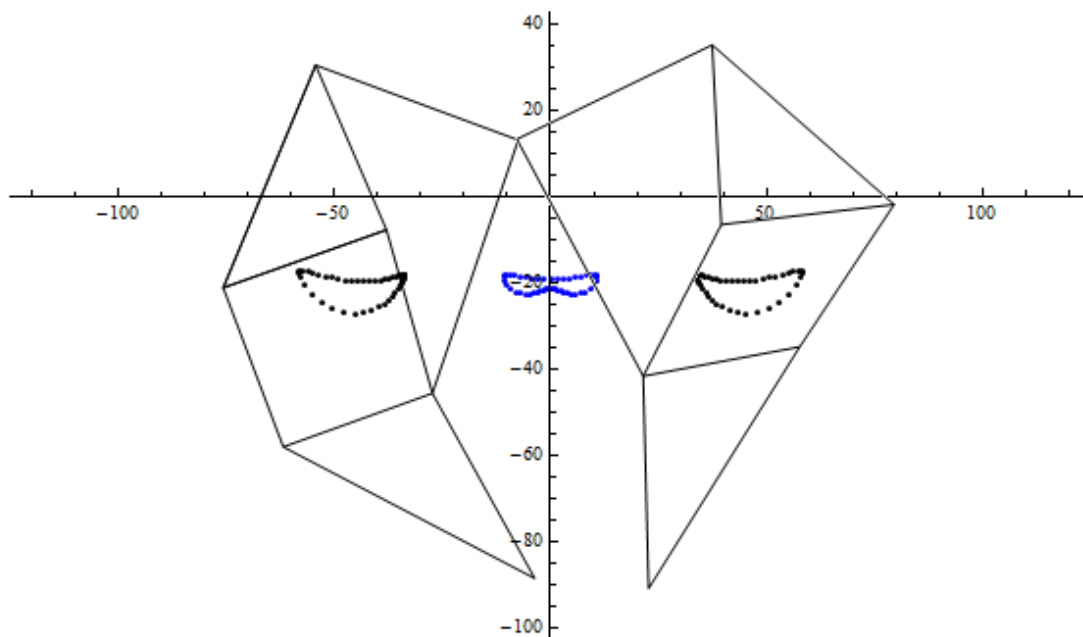

Figure 3.3.19: Plot of the position of the center of mass of each contributing leg of Theo Jansen mechanism in black with total center of mass of the leg pair in blue for one locomotive cycle. A pair of legs is also plotted at an arbitrary time step for reference.

Figure 3.3.19 shows that the addition of a leg pair cancels out the magnitude of movement of the total cm by about $\frac{1}{2}$ in the y direction and about $\frac{1}{5}$ in the x direction.

3.3.7 Phasing of Leg Pairs

The phasing of the leg pairs on the crank helps to cancel out center of mass movements throughout the locomotive cycle. In the following example, I will consider three pairs of Theo Jansen legs that are each 120 degrees out of phase from one another (see figure below).

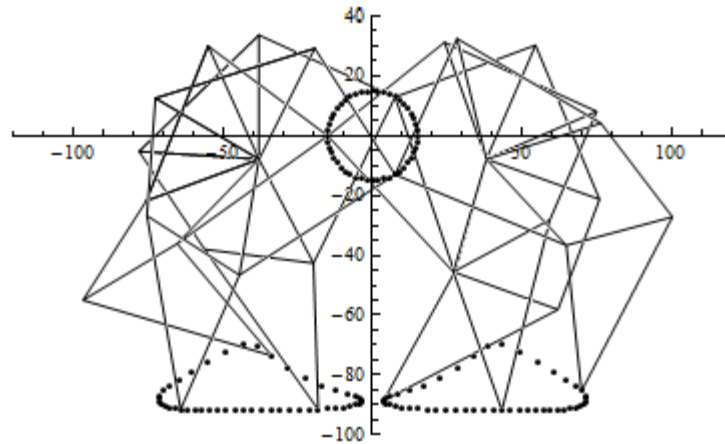

Figure 3.3.20: A set of three pairs of Theo Jansen legs with crank and foot locus indicated. Each pair is out of phase with the other two pairs by one third of a cycle so that at least one leg on each side of the crank is on the ground for the entire locomotive cycle.

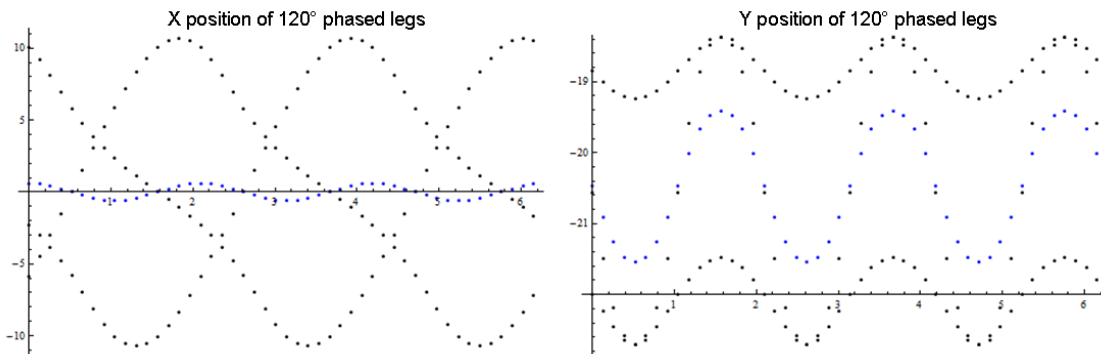

Figure 3.3.21: x and y position of cm of individual leg pairs shown in black and total six legged walker in blue for entire locomotive cycle.

As shown in the plots above, the phasing of three pairs of Theo Jansen legs decreases the overall movement of the center of mass throughout the locomotive cycle. A plot of the new center of mass trajectory is shown in the figure below. The oval path is traced out three times during one locomotive cycle. Figure 3.3.22 shows the magnitude of the center of mass movement compared to the size of the legs.

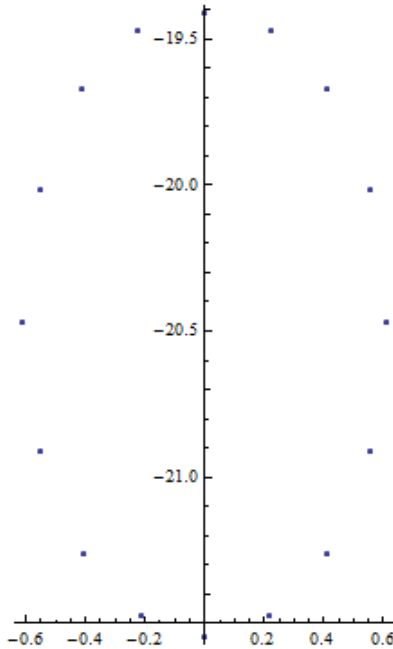

Figure 3.3.21: path of center of mass for six legged Theo Jansen walker with leg pairs 120 degrees out of phase from one another. Path is traced out three times during one locomotive cycle.

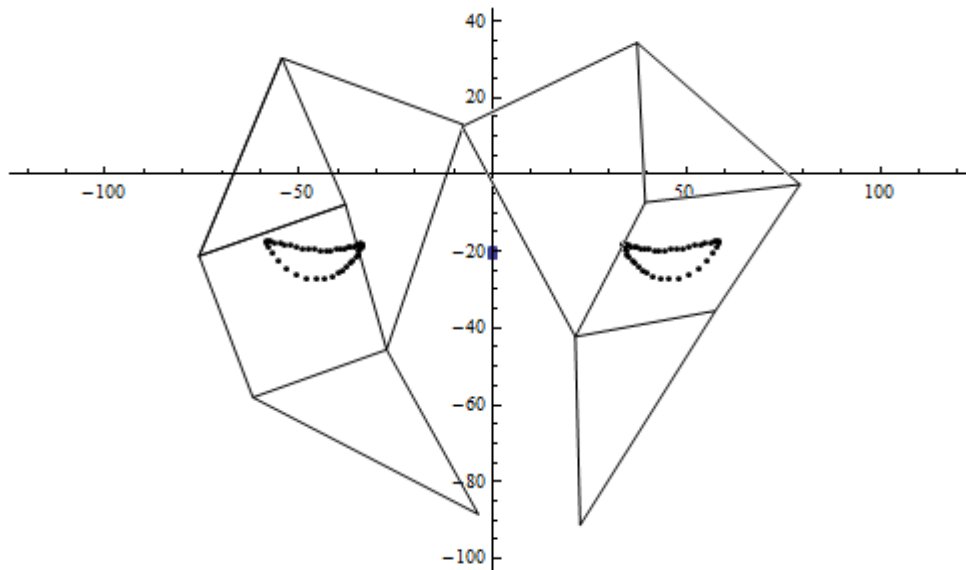

Figure 3.3.22: Center of mass plotted in blue for one locomotive cycle on top of diagram of one leg pair. Plot of center of mass of one left and one right leg are shown in black for comparison.

The following table shows a summary of the CM data for the Theo Jansen Mechanism. I subtracted the minimum and maximum x and y coordinates of the position of the total center of mass for one leg, a leg pair, and three 120° out of phase leg pairs.

The raw data from this table will be normalized to the step height of the Theo Jansen mechanism for comparison with my own design in section 6.6.

Table 3.3.3 Analysis of CM movement of Theo Jansen Mechanism (not normalized)

CM Y deviation (one leg)	9.8
CM X deviation (one leg)	24.7
CM Y deviation (leg pair)	4.3
CM X deviation (leg pair)	21.3
CM Y deviation (three leg pairs)	2.1
CM X deviation (three leg pairs)	1.2

Chapter 4: Design and Analysis of Walking Mechanism

4.1 Introduction

My final leg linkage design with optimized parameters and locus plot is shown in figure 4.1.1. In this chapter I will describe the process that allowed me to arrive at this linkage design, and in Chapter 5 I will explain the optimization process that allowed me to refine the locus to the shape shown below.

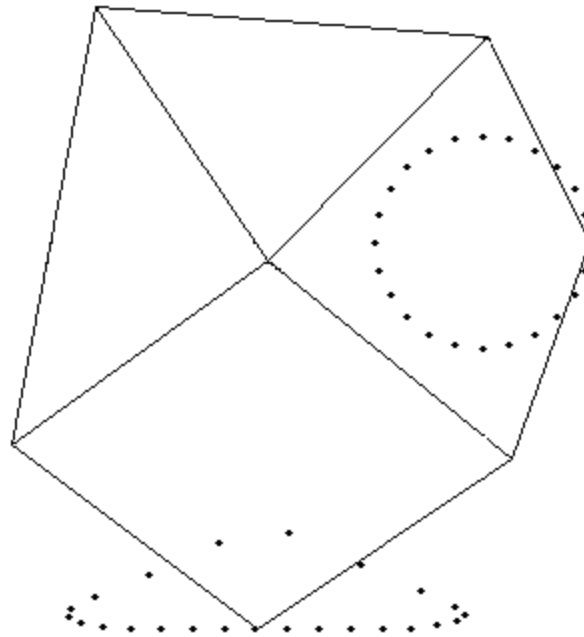

Figure 4.1.1: Original leg linkage design with optimized parameters. Position of crank and foot are shown for twenty four time steps.

My main objectives for the leg design are listed below:

- **Simplicity of design**
I would like to design a leg mechanism which uses less than ten linkages (the Theo Jansen mechanism uses ten linkages). This will make the optimization and construction processes more simple.
- **Symmetry of locus across y-axis (see Figure 4.1.2)**
Increased symmetry will allow for greater energy efficiency because opposite pair will cancel out movement in x and y directions. The Theo Jansen mechanism does not have symmetry across the y-axis. I plan on employing symmetry in my design in order to produce symmetry in the locus.
- **$\beta \geq \frac{1}{2}$**
 β must be at least $\frac{1}{2}$ for linkage to be useful in a gait, otherwise the leg will spend most of the time in the return phase during a locomotive cycle.

- Straightness and constant velocity of stride
In order to construct multi-legged walker with no leg dragging, height and speed of walker must be constant during locomotion.

My ideal locus is pictured below:

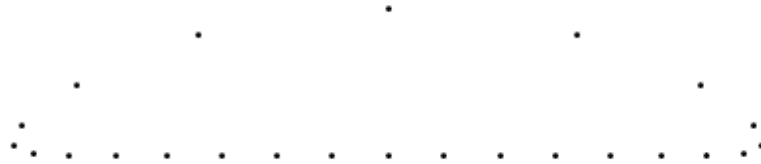

Figure 4.1.2: Ideal locus shape plotted out over 24 equally spaced time steps. Notice symmetry about the y axis, beta greater than $\frac{1}{2}$, and straightness and constant velocity of stride phase

4.2 Design Process

I used two strategies to arrive at my final linkage design. The first was replicating the angular movement of a Mathematica simulation of a four-bar linkage tracing out my ideal locus path. The second was an approximation method described in section 3.3.3 “Understanding the movement of the Theo Jansen Mechanism.”

4.2.1 Chebyshev Replication

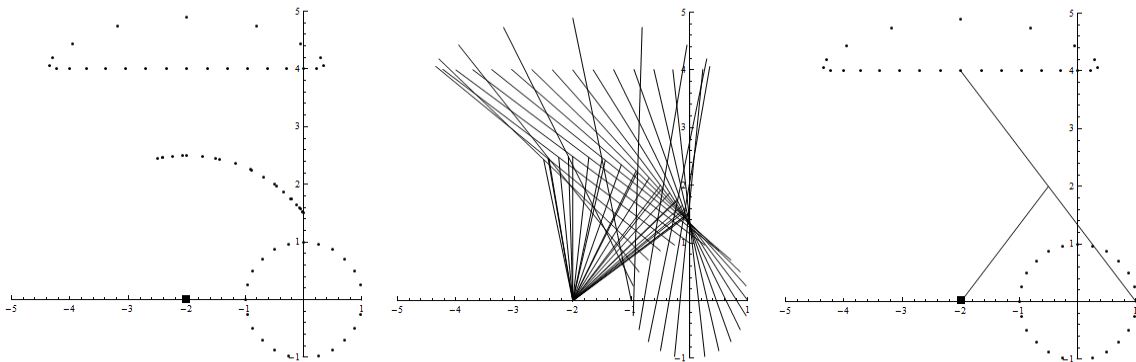

Figure 4.2.1: Chebyshev linkage shown three times over 24 equally spaced time steps. The path traced out by the linkage is my ideal foot locus, but it must be inverted to be useful for locomotion. The black square represents a fixed point in the linkage relative to the central crank axis.

My ideal locus path can be traced out by the Chebyshev linkage which is shown in Figure 4.2.1. The only problem with the Chebyshev linkage is that the crank and the

rest of the linkage are located underneath the locus. This makes the linkage unsuitable for walking in its current form.

In order to investigate the possibility of manipulating this linkage so that it can be used as a leg, I flipped the linkage over the x-axis so that the crank and other linkage parts are located above the locus (Figure 4.2.2 A). The new locus maintains the same shape but is inverted. I attached the inverted Chebyshev linkage to an inverting linkage so that the locus will be flipped over to its original position (Figure 4.2.2 B). Although the torque on the inverted Chebyshev linkage is too great to make it a useful leg mechanism, it can be used to study the ideal movement of a four bar linkage when tracing the ideal locus.

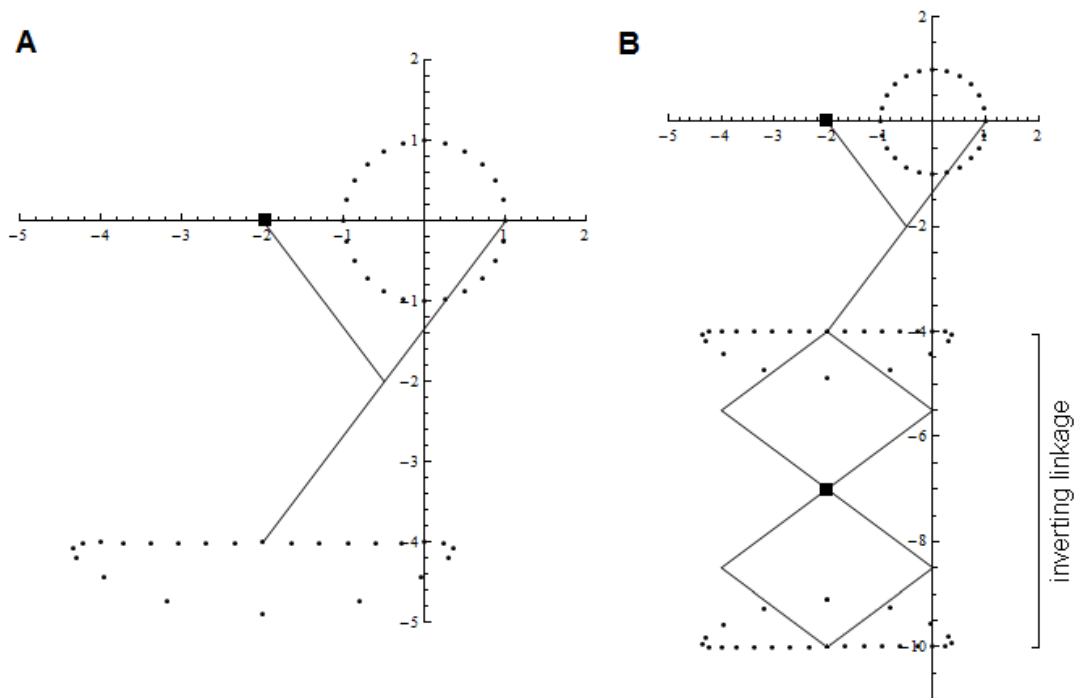

Figure 4.2.2: A: Chebyshev linkage flipped over the x axis. B: Flipped Chebyshev linkage attached to an inverting linkage to reproduce correctly oriented locus. Black squares indicated fixed points in the linkage.

Figure 4.2.3 shows the bottom four bar linkage of the inverted Chebyshev linkage tracing out the ideal locus with its bottom hinge. The four bar linkage is comprised of four rigid bodies which are all the same length. The left and right hinges trace out semicircles around the fixed point at the top of the four bar linkage as indicated by the points plotted in Figure 4.2.3. A more detailed angular analysis of this movement is given in Figure 4.2.4.

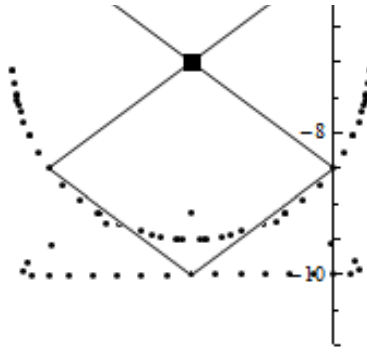

Figure 4.2.3: Symmetric movement of four bar linkage which traces out correctly oriented Chebyshev locus. The positions of all three moving hinges of four bar linkage are plotted over twenty four equally spaced time steps for an entire locomotive cycle.

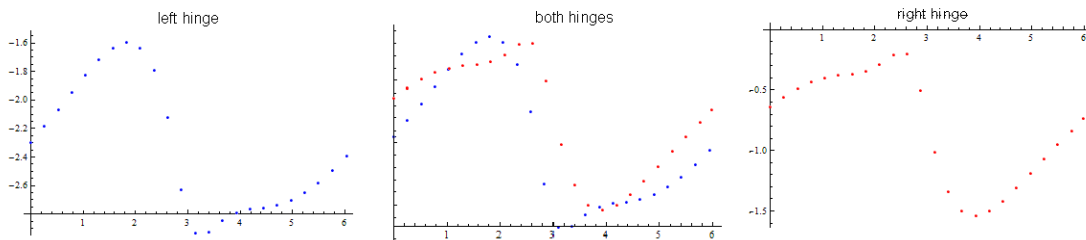

Figure 4.2.4: Angular movement of left and right hinges of four bar linkage pictured in Figure 4.2.3 about the fixed point for one locomotive cycle. The x axis is the angular position of crank θ , and y axis is angular position in radians. Middle graph shows both left and right plots overlaid (note the y axis in middle plot shows magnitude of angular movement, not absolute angular position) for comparison.

From this analysis, I determined the angular movement needed for a four bar linkage of equal length sides with one fixed hinge to trace out my ideal locus path. This movement is outlined generally in Figure 4.2.5. The left and right hinges move at an approximately constant angular speed during the support phase of the locomotive cycle (Figure 4.2.5 A). To initiate the lift, the innermost hinge must begin moving in the opposite direction slightly before the outer hinge (Figure 4.2.5 B). This causes the four bar linkage to expand horizontally, which moves the foot up. To initiate the lower, the outermost hinge must switch directions slightly before the inner hinge (Figure 4.2.5 C). This causes the four bar linkage to contract horizontally, which moves the foot down. Another important quality of the angular movement is that both hinges move slowly in one direction and quickly in the other. The slow direction corresponds to the support phase and the fast direction corresponds to the return phase. This quality allows for $\beta \geq \frac{1}{2}$.

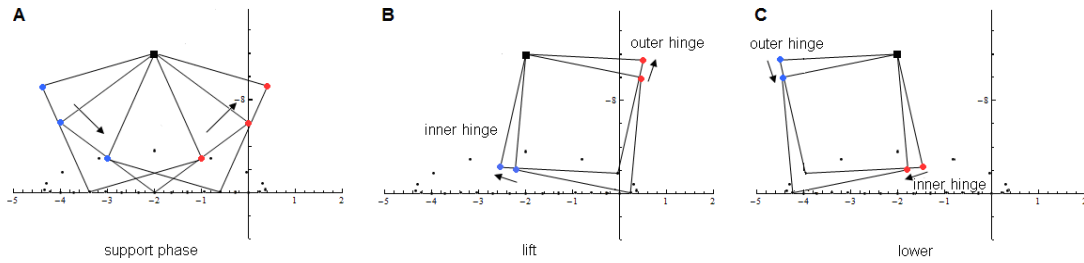

Figure 4.2.5: Movement of four bar linkage tracing out ideal locus path. A shows approximately constant velocity of left and right hinges during support phase. B shows horizontal expansion of linkage during lift. C shows horizontal contraction of linkage during lower.

In summary, this analysis proves that a four bar linkage can trace out my ideal foot path if two of the hinges move circumferentially with respect to a third hinge, and with a slight phase difference in their movement. In the next section I will show how I reconstructed this movement using a component borrowed from the Theo Jansen mechanism (Figure 4.2.6). As shown in the diagram below, by linking a crank to a fixed hinge with a four bar linkage, you can move the other two hinges with an angular position of approximately $\sin(\theta)$ and $-\cos(\theta)$.

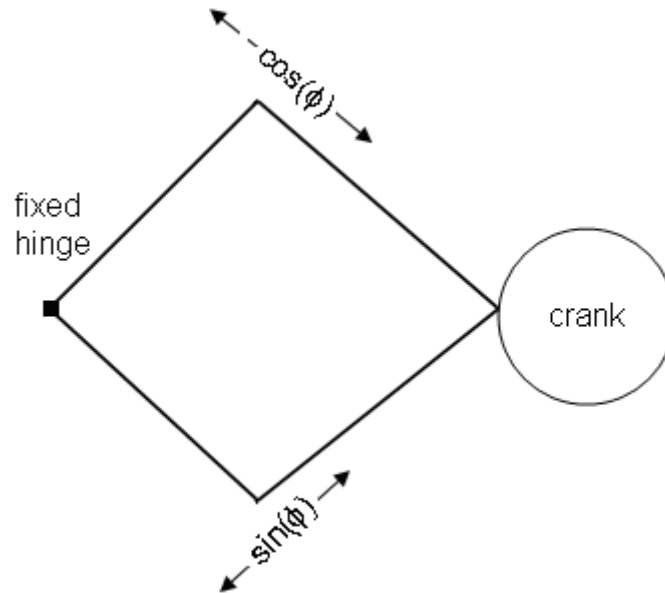

Figure 4.2.6: Part of Theo Jansen mechanism, which generates movement that approximates sin and -cos. The manipulation of this sin and -cos movement was the basis of my synthesis of a leg design.

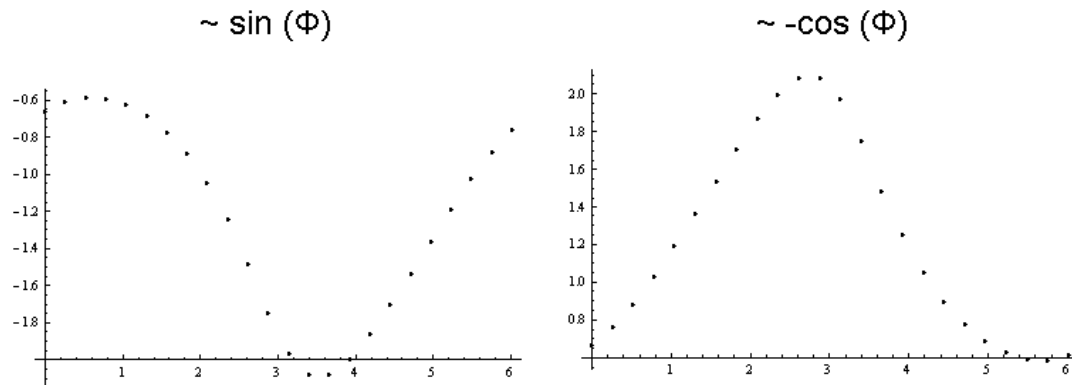

Figure 4.2.7: Plots of angular position of hinges from Figure 4.2.6 tracing out approximately sin and $-\cos$ movement.

4.2.2 Mechanism Movement Approximation

Beginning with the mechanism in Figure 4.2.6 as a base, I generated the mechanisms of Figure 4.2.8. These linkages translate the sin and -cos movement from the four bar linkage attached to the crank to the four bar linkage responsible for producing the locus. As indicated in Figure 4.2.8, the differences in the linkages cause this sin and -cos movement to be translated with different orientations.

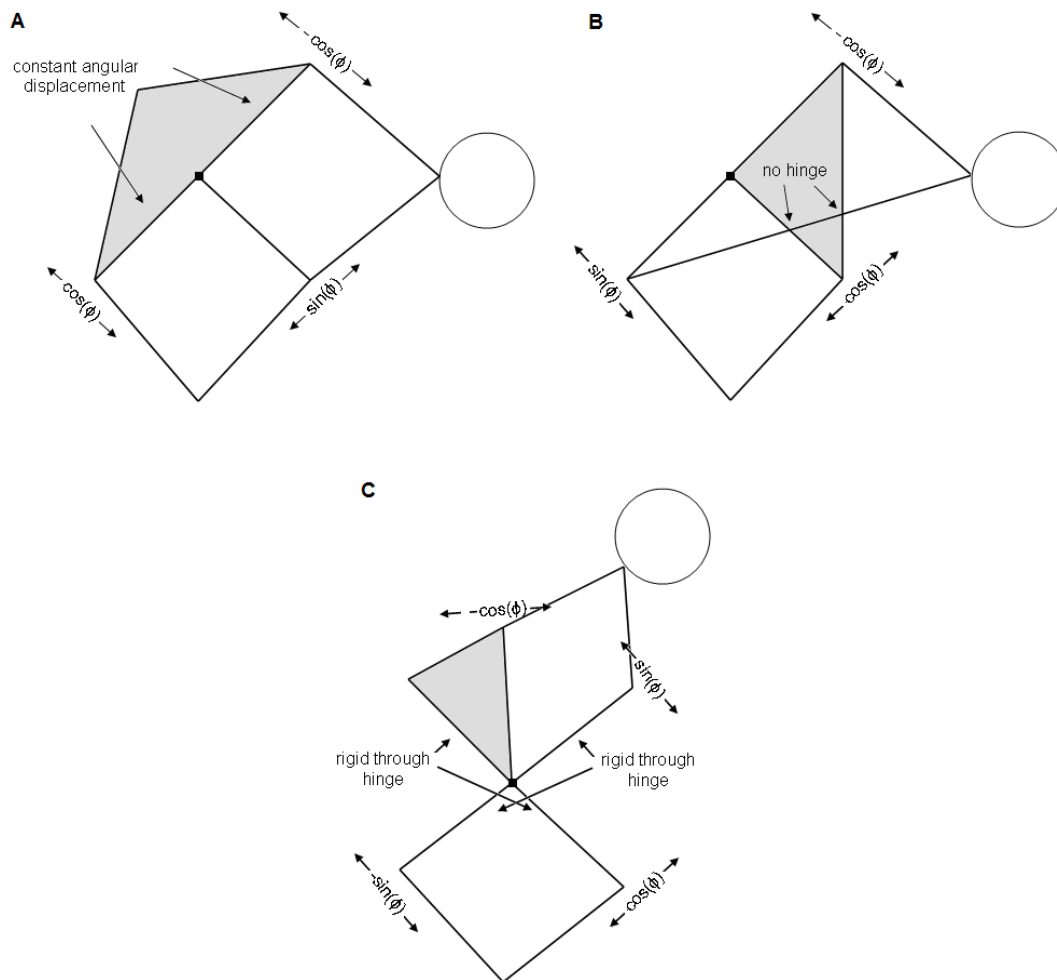

Figure 4.2.8: Three mechanisms which use a four bar linkage to trace out a foot. Approximations of angular hinge movement are indicated with $\pm\sin(\phi)$ and $\pm\cos(\phi)$, where ϕ is the position of the crank.

Although the mechanism from Figure 4.2.6 can be approximated as producing movement in the hinges according to $\sin(\phi)$ and $-\cos(\phi)$, it is important to remember where this approximation breaks down. Note that there is a fast and slow direction of movement in Figure 4.2.7. As demonstrated again in Figure 4.2.9, the top hinge (shown in blue) moves quickly as it heads towards the crank and the bottom hinge (shown in red) moves quickly as it heads away from the crank. It is important to consider this in the leg design because ideally we want the fast movement to correspond to the return phase and the slower movement to correspond to the stride phase.

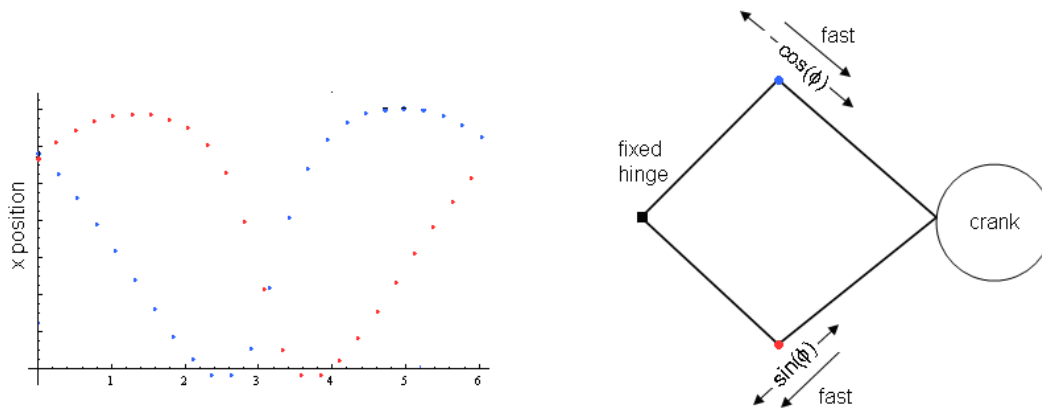

Figure 4.2.9: The movement of the top and bottom hinges of a four bar linkage with respect to position θ are plotted. As indicated in the diagram, the top hinge (blue) moves more quickly as it heads toward the crank and the bottom hinge (red) moves more quickly as it heads away from the crank for constant crank rotation in the counterclockwise direction.

Incorporating the fast and slow direction of movement into the diagrams from Figure 4.2.9 gives Figure 4.2.10. Figure 4.2.11 shows an approximation of the x position of the left and right hinges of Figure 4.2.10 plotted for an entire cycle with the faster part of the cycle indicated with text. Hypothetical loci are pictured below each plot based on the reasoning behind Figure 4.2.5.

As shown in Figure 4.2.11, only mechanisms A and C will produce a locus with $\beta \geq \frac{1}{2}$ because the period of slower hinge movement corresponds to the stride phase and the period of fast hinge movement corresponds to the return phase. I chose to continue into the optimization process with mechanism A for the following reasons:

- Lower center of gravity
- Simplicity of design (less hinges and rigid bodies)
- Shorter linkage lengths when normalized to size of locus (less torque on rigid bodies)

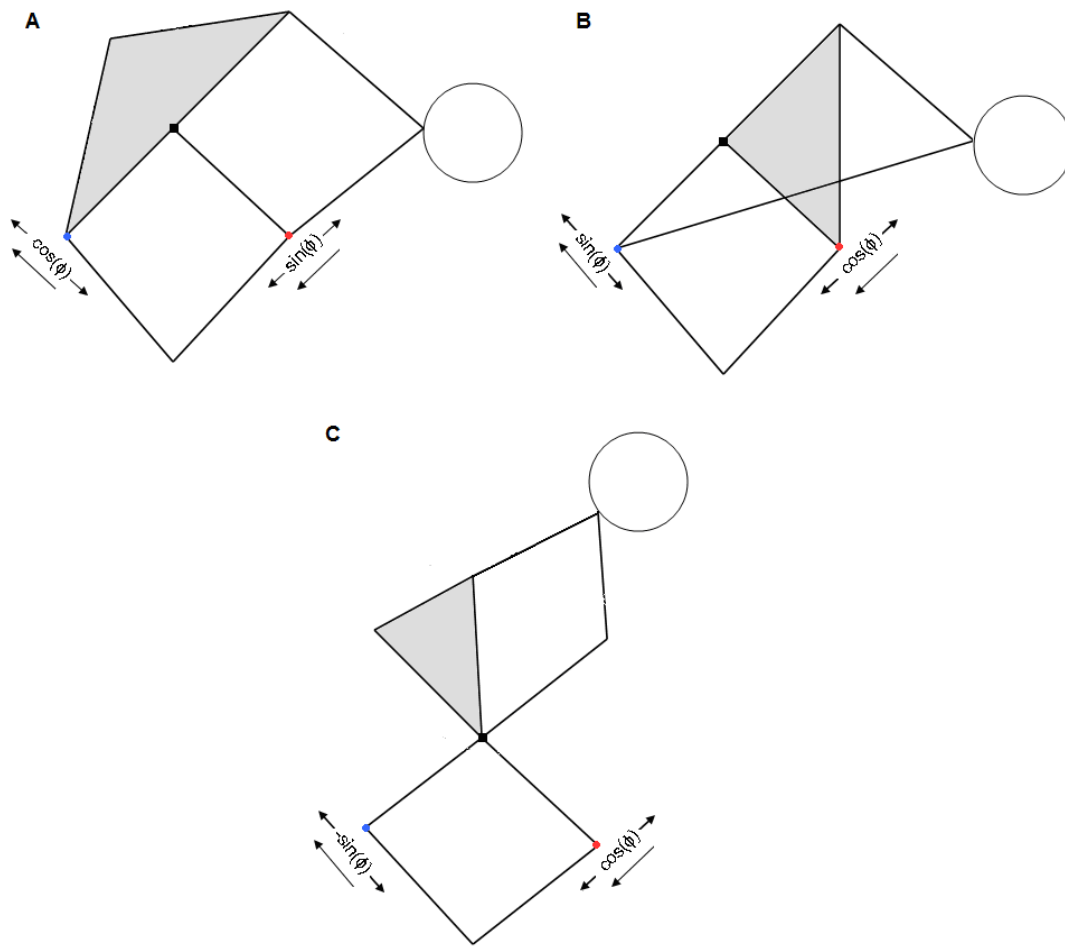

Figure 4.2.10: Leg mechanisms from Figure 4.2.8 with direction of more rapid movement indicated by arrow.

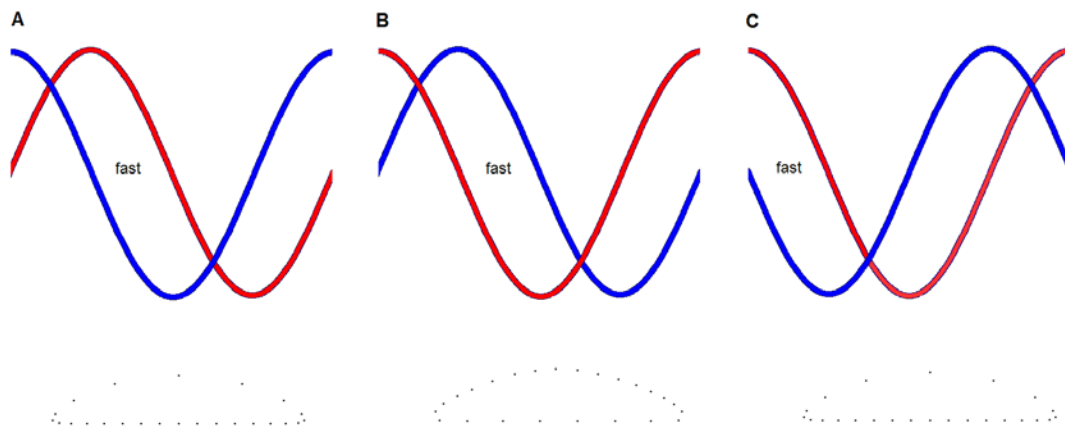

Figure 4.2.11: Approximation of left (blue) and right (red) hinge x positions for three mechanisms for one locomotive cycle shown in Figure 4.2.10 with period of fast hinge movement indicated. Theoretical loci are drawn below each graph.

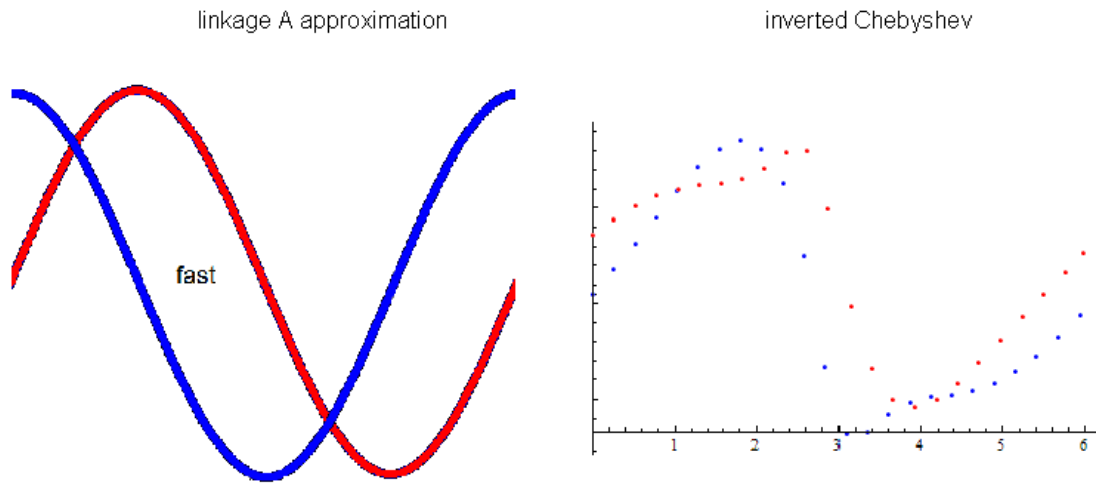

Figure 4.2.12: Comparison of the approximate angular movement of linkage A with the movement necessary for the ideal locus (from Figure 4.2.4). Notice the similarities in the movement of the left (blue) and right (red) hinges during the faster return phase of the locomotive cycle.

The figure above shows the similarity of the angular movement of the left and right hinges of mechanism A with the inverted Chebyshev model. In the next section I will model mechanism A in Mathematica and optimize it so that it most closely follows the inverted Chebyshev angular position plot.

using a Monte Carlo optimization process until I found a linkage which best traces my ideal locus.

5.2 Symmetry of Design

One of my objectives for the shape of the locus was symmetry across the y axis. I accomplished this by incorporating symmetry in the optimization of the linkage lengths. A symmetric locus is most easily achieved with a four bar linkage that has mirror symmetry in its linkage lengths (Figure 5.2.1).

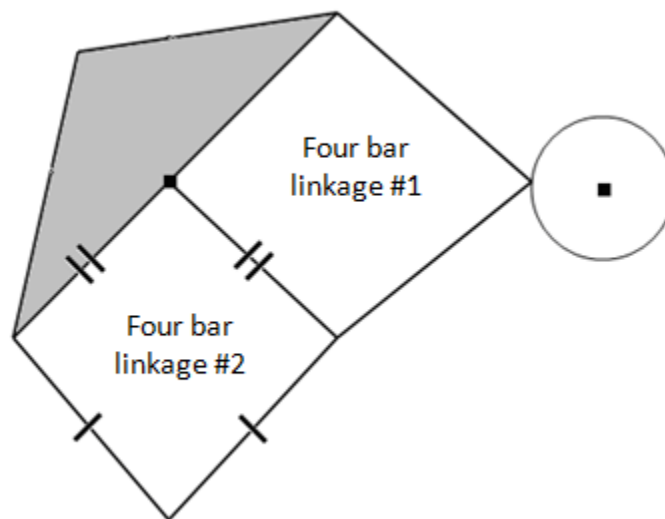

Figure 5.2.1: Mirror symmetry in foot four bar linkage of leg mechanism indicated with hash marks

Additionally, the left and right hinges of four bar linkage #2 must move in an angular pattern which is mirror symmetric but also out of phase. The only way to satisfy this constraint is to impose mirror symmetry on four bar linkage #1 (Figure 5.2.2).

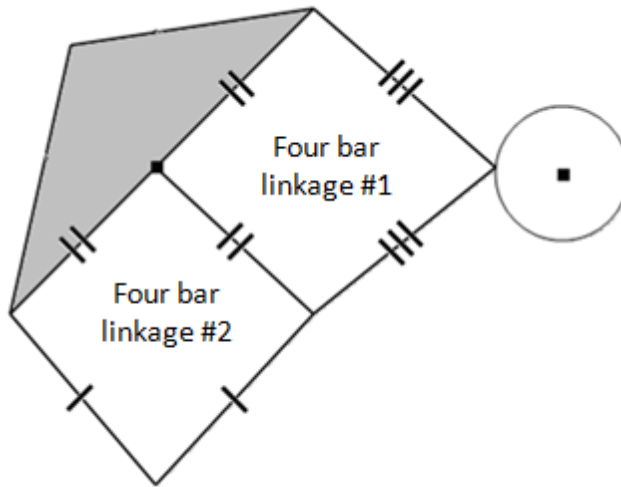

Figure 5.2.2: Mechanism with length symmetry indicated by hash marks.

5.3 Four Bar Linkage #1 Optimization

Figure 5.3.1 and 5.3.2 are close up views of the four bar linkage to be optimized with numbering system, naming system, and symmetry indicated. There are four parameters which I must explore for this part of the optimization:

- Length of crank shaft
- Distance of crank from fixed hinge
- Length of crank rods
- Length of hinge rods

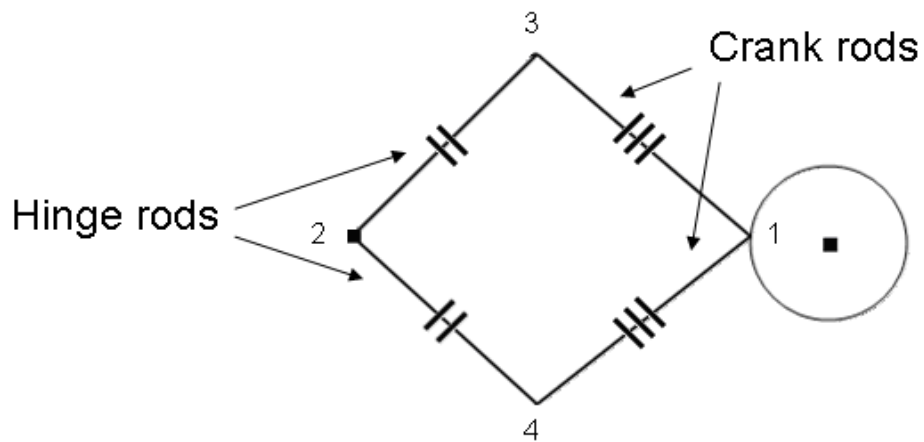

Figure 5.3.1: Numbering system of four bar linkage with “hinge rods” and “crank rods” labeled. Symmetry indicated with hash marks.

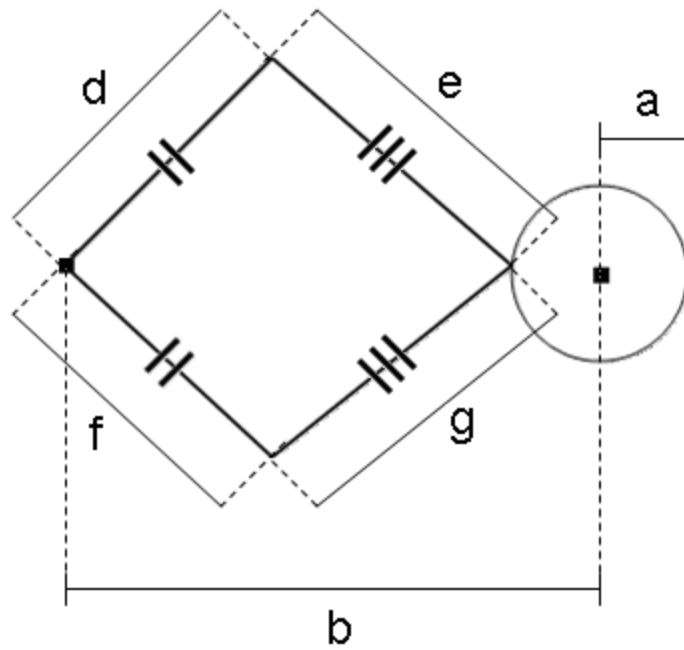

Figure 5.3.2: Naming system of lengths of rigid bodies in four bar linkage. For this portion of the optimization, the fixed points have no y displacement between them.

There are two specific goals in this part of the optimization (both are indicated graphically in Figure 5.3.3):

1. The first turning point of hinge three must be slightly ahead of the first turning point of hinge four
2. The fast part of the cycle must follow the first turning point and must be considerably faster than the rest of the cycle

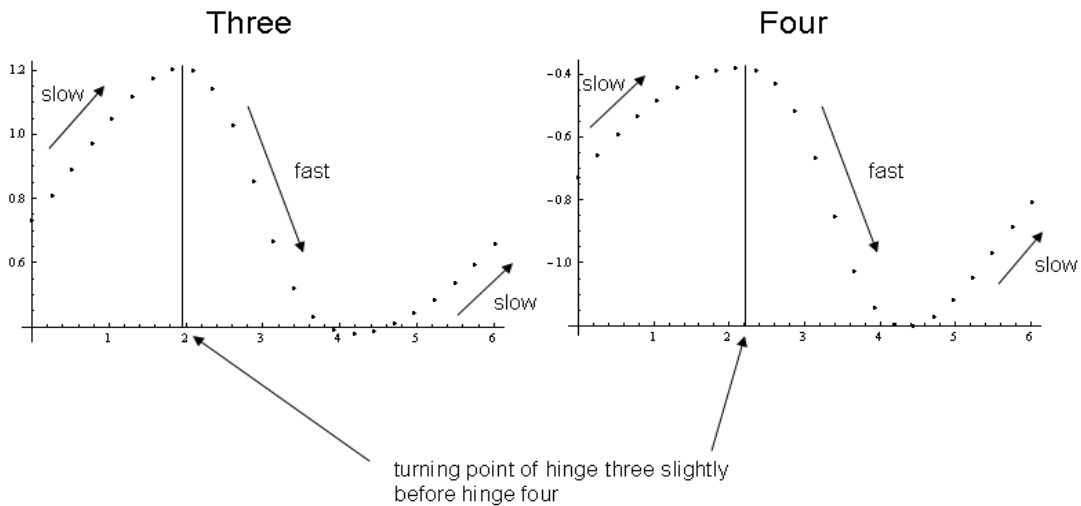

Figure 5.3.3: The goals of four bar linkage #1 optimization represented graphically.

A summary of the results of these tests based on the goals stated above is shown in Table 5.3.1. A selection of the plots I generated during the optimization is given in Appendix C.

Table 5.3.1: Summary of results from four bar linkage #1 optimization

Parameter	Improved relative turning points of hinges three and four	Increased speed of “fast” portion of cycle
Length of hinge rod	Long hinge rod	Long hinge rod
Distance of fixed hinge from crank axis	Hinge close to crank	Hinge close to crank
Radius of crank	Large crank	Large crank
Radius of crank (constant distance between edge of crank path and fixed hinge 2)	Large crank	Large crank
Crank rod length	Short crank rod	Little effect
70:50 ratio of rods	Long hinge rod	Long hinge rod
30:50 ratio of rods	Long hinge rod	Long hinge rod
70:50 and 50:30 ratios	70:50	70:50
Overall length of rods	Little effect	Long rods

From this analysis I determined that ideally the ratio of the lengths of the hinge rods to the crank rods should be greater than one, the crank radius should be large, and the overall length of the rods should be longer rather than shorter. I used this information as a starting point for my next analysis of the entire leg linkage as a whole.

5.4 Full Linkage Optimization

The naming and numbering system for the full linkage optimization is given in Figure 5.4.1. I began this optimization by varying the values of a, b, l, and m while keeping the average radial distance between hinges four and five constant (thereby also varying the angular displacement of the linkage). I was interested in finding a combination of linkage lengths which was capable of generating my ideal locus, but I wasn't concerned with the spatial orientation of the locus with respect to the x and y axes in this stage of the optimization. I used the information in Table 5.2.1 along with my ideal angular plots of hinges three and four (Figure 4.2.12) to arrive at a solution more quickly. Appendix D shows some sample plots I generated during this analysis. The last part of the optimization was to change the value of theta so that the optimized locus shape had a support phase which was parallel to the x axis.

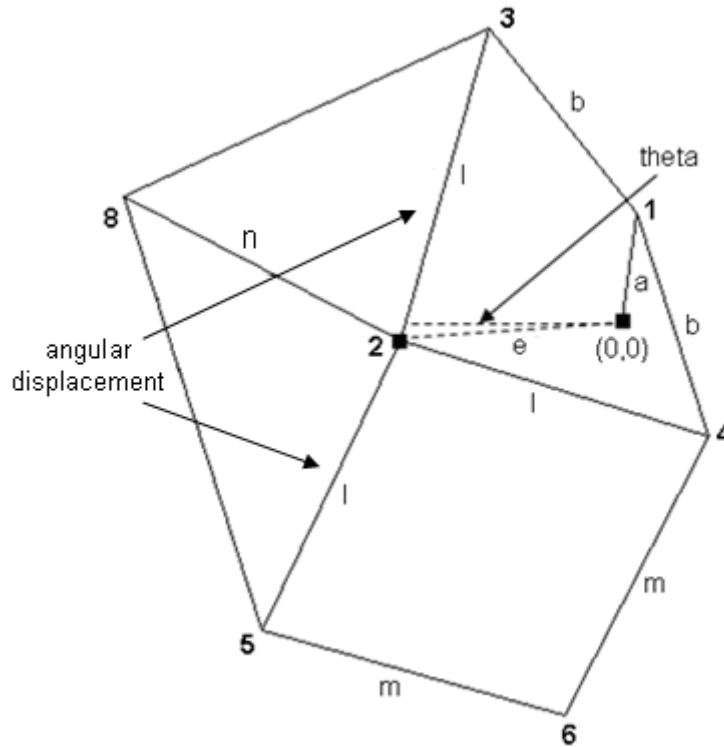

Figure 5.4.1: Naming and numbering system for full linkage optimization.

From this analysis I found that there is not just one “optimal” solution, but instead a range of solutions which produce satisfactory loci for my purposes. I did not anticipate that factors other than the shape of the locus would influence my optimization process, but I found that many solutions which gave good loci also let hinges four and five fall below the maximum step height of the foot. This phenomenon is illustrated in Figure 5.4.2. I had to modify the objectives of the optimization to both create an ideal locus, and to also not allow hinges four and five to fall significantly below the maximum step height of the foot.

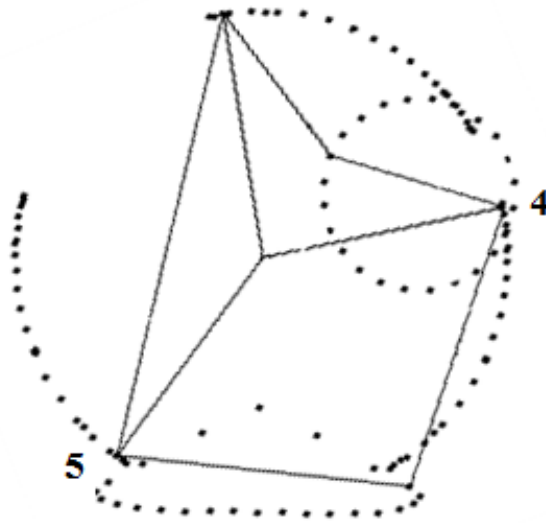

Figure 5.4.2: Optimized linkage with good locus shape, but hinges four and five fall below maximum step height, thus, reducing the step height of the leg by about 50%.

An optimized solution is shown in Figure 5.4.3. It is important to note that the constant angular displacement of 2.97 radians can be achieved with a variety of different structures; I chose parameters which I hoped would move the center of mass of the leg closer to the fixed hinge, thereby reducing CM movement during locomotion.

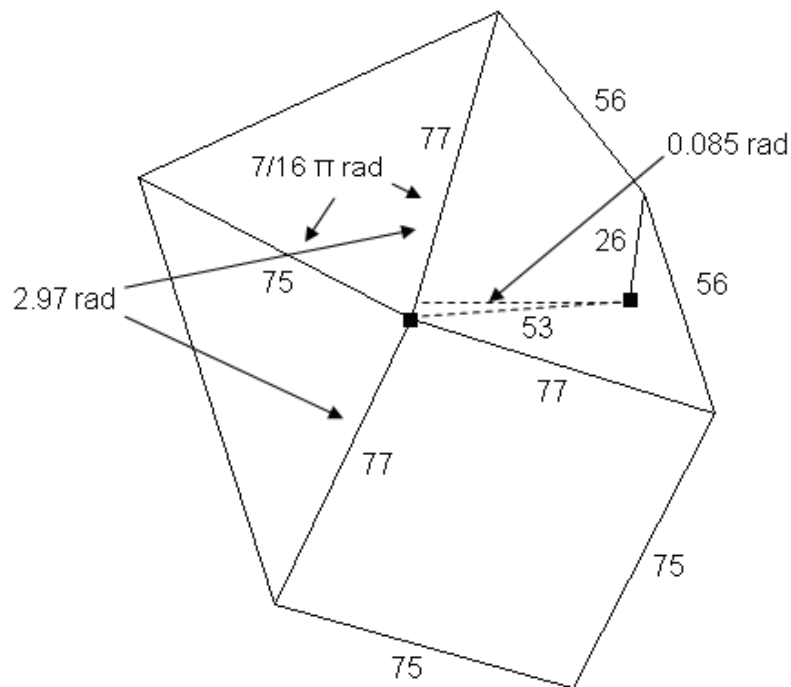

Figure 5.4.3: Optimized solution with measurements indicated.

Another solution I explored which minimizes the variation in linkage lengths is given in Figure 5.4.4. The loci of the solutions shown in Figure 5.4.3 and 5.4.4 are almost identical.

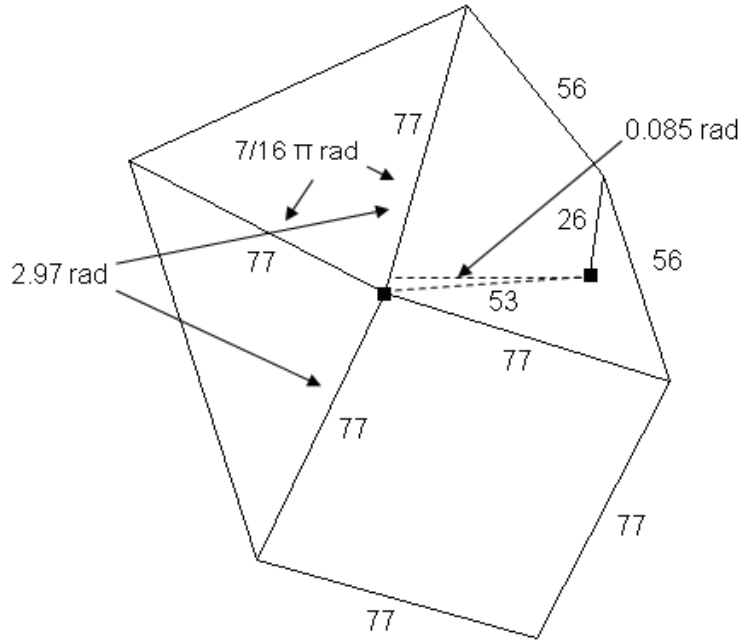

Figure 5.4.4: Additional optimized solution with measurements indicated.

In the next chapter, I will analyze the solution of Figure 5.4.3 and compare it with the Theo Jansen mechanism.

Chapter 6: Analysis and Comparison with Theo Jansen

6.1: Introduction

In this chapter I will be analyzing my model with the same methods described in Chapter 3 and comparing my results with the Theo Jansen model found in Chapter 3 and Appendix B. I will normalize both mechanisms so that their stride lengths are equal to one and assess the quality of their loci as well as the movement of their centers of mass during locomotion. The figure below shows the numbering system I will use for this analysis.

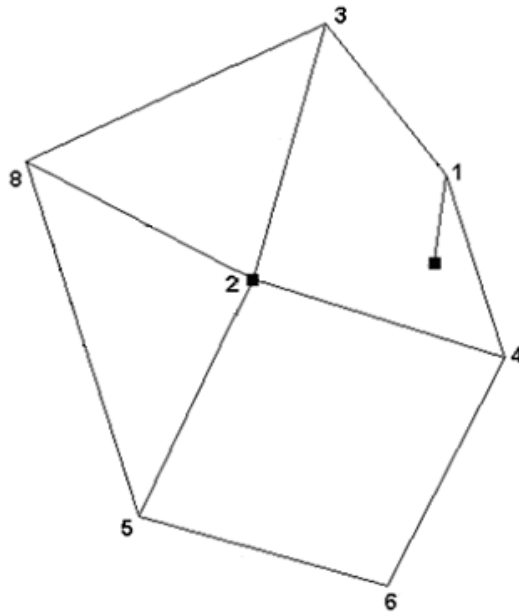

Figure 6.1.1: Numbering system of optimized mechanism from Figure 5.4.3.

6.2: Position Plots

Figure 6.2.1 shows the position each of the moving hinges in the mechanism plotted over 24 time steps spanning one complete locomotive cycle. Notice how the position of hinges 4 and 5 does not dip significantly below the maximum step height of the foot. Figure 6.2.2 shows the mechanism plotted over twenty four time steps on the same set of axes.

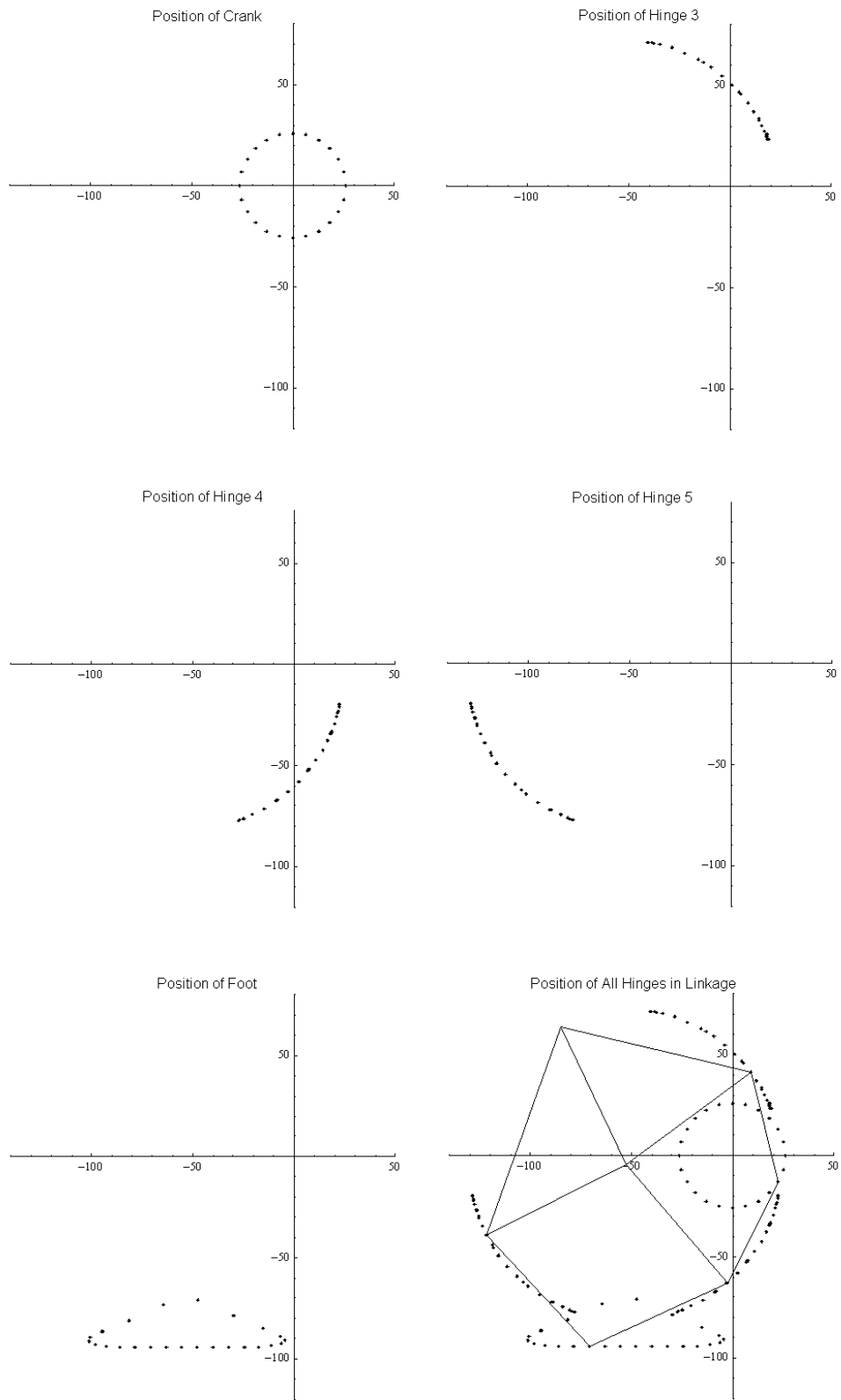

Figure 6.2.1: Movement of hinges over 24 equally spaced time steps of a complete locomotive cycle.

Linkage Position During Complete Locomotive Cycle

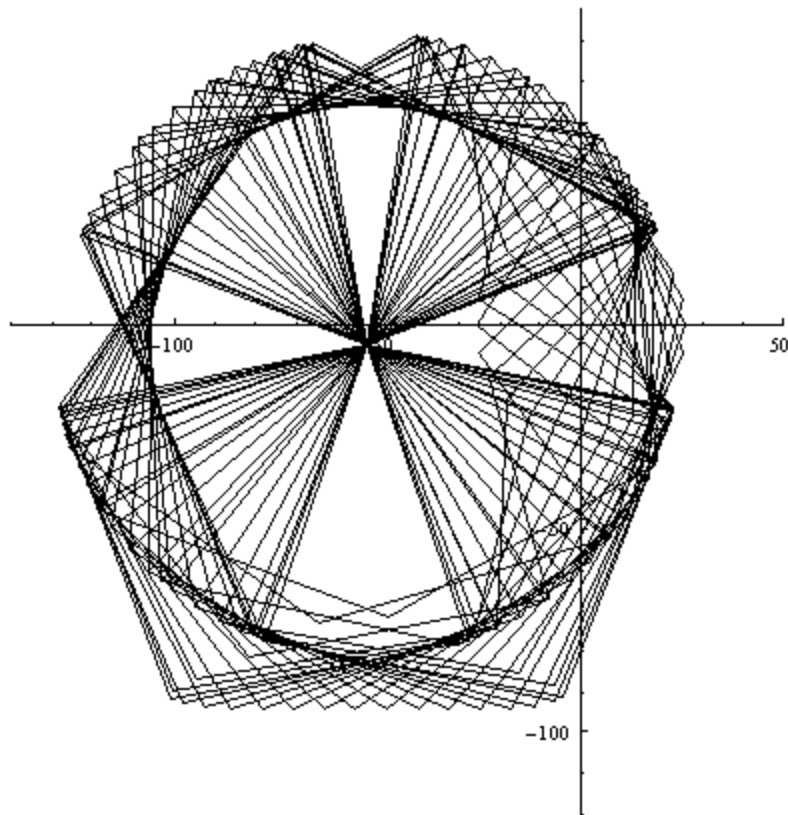

Figure 6.2.2: Position of leg linkage over twenty four evenly spaced time steps of one complete locomotive cycle.

Figure 6.2.3 demonstrates the time evolution of the linkage over twelve time steps spanning one locomotive cycle.

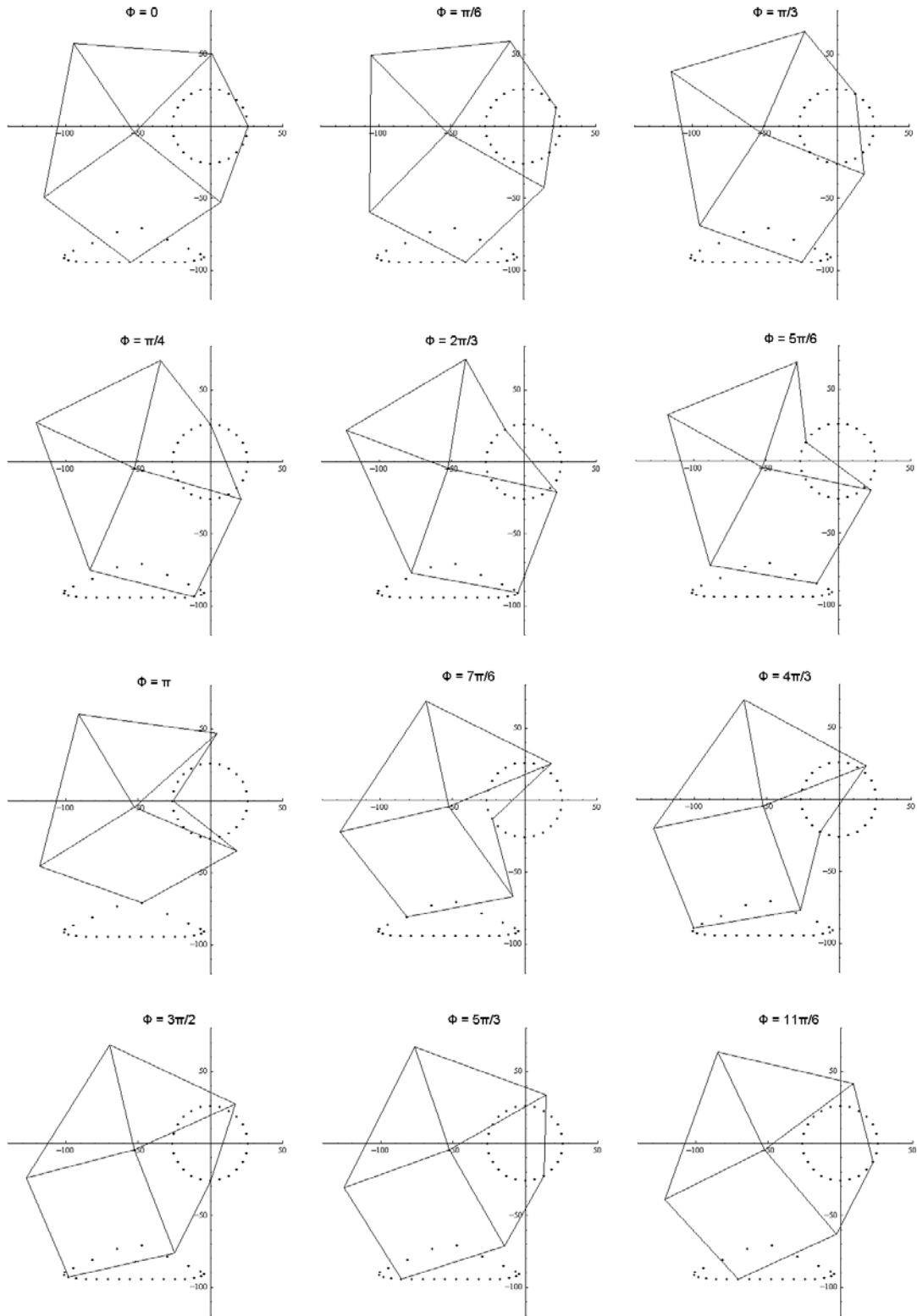

Figure 6.2.3: Movement of linkage over twelve equally spaced time steps of a full locomotive cycle. Angular position of crank indicated for each figure. Crank path and locus also plotted for twenty four time steps.

6.3 Locus Analysis

Figure 6.3.1 shows a close-up of the locus with step height and stride length indicated. Table 6.3.1 gives the non-normalized values of stride length and step height for the Mathematica parameters given in section 5.4. These values will be normalized in section 6.6 for comparison with the Theo Jansen locus.

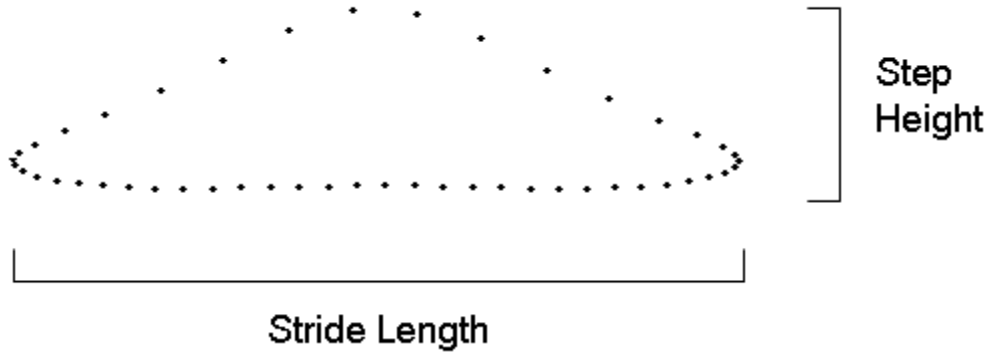

Figure 6.3.1: Locus of mechanism with step height and stride length indicated.

Table 6.3.1: Analysis of locus (not normalized)

Stride Length	97.0
Step Height	24.2

The support phase (the half of the cycle when the foot is positioned the lowest in the y direction) of the locus is shown in blue in Figure 6.3.2 below. This plot is reproduced in Figure 6.3.3 with unequally scaled axes so that small deviations in height of the support phase become more apparent. Additionally, Figure 6.3.5 shows the angular position of the crank during the support phase.

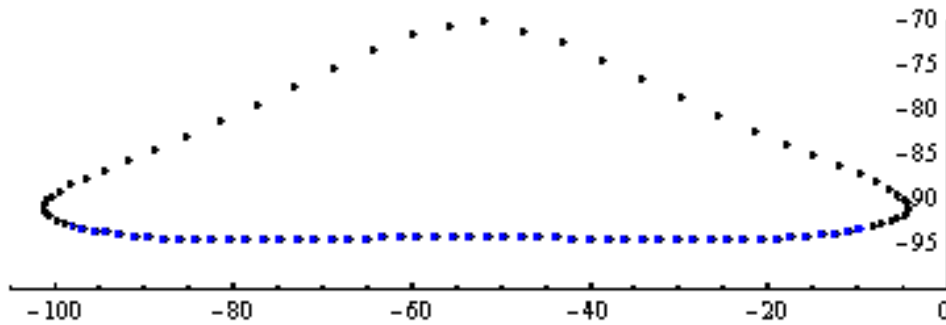

Figure 6.3.2: Support phase shown in blue with rest of locus in black over 96 time steps. Axes scaled equally.

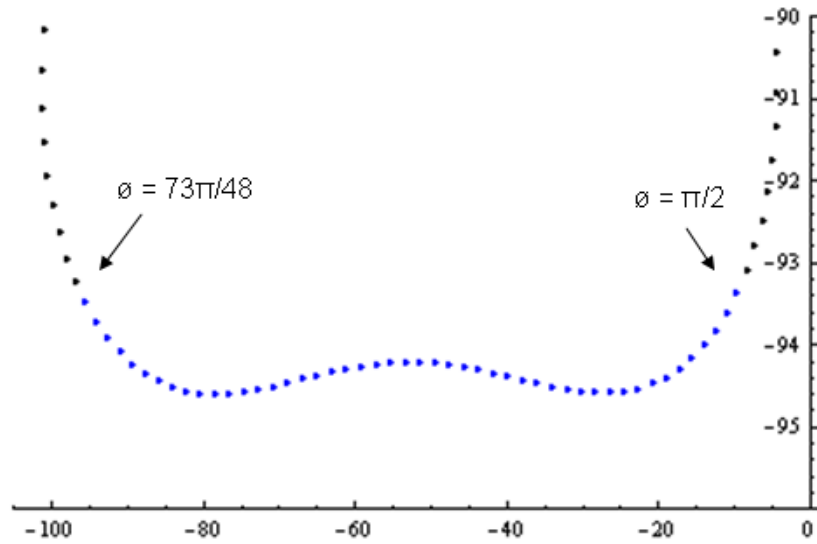

Figure 6.3.4: Support phase shown in blue over 96 time steps with position \varnothing of lift and lower phases indicated. Axes have been scaled differently to highlight the small deviations in height of the support phase. See Figure 6.3.5 for corresponding angular position of crank.

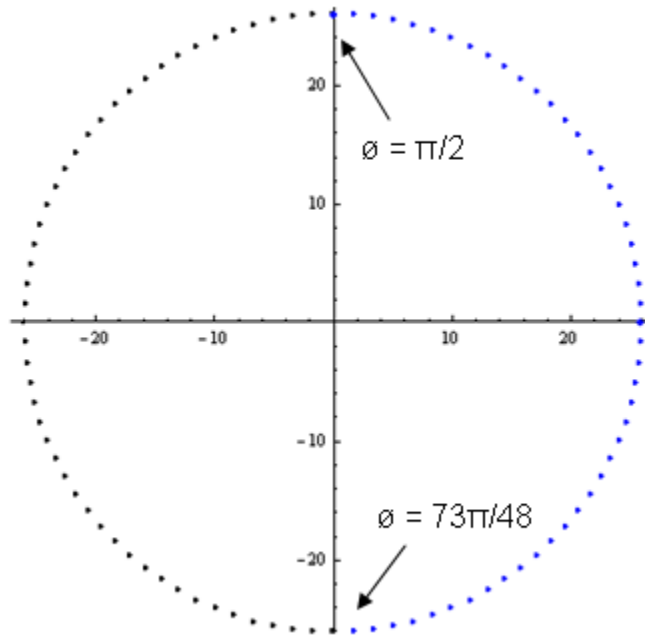

Figure 6.3.5: Angular position of crank during support phase (blue) and return phase (black). Start of support phase is indicated at $\varnothing = 73\pi/48$ and end is indicated at $\varnothing = \pi/2$.

Figure 6.3.6 and 6.3.7 show the x velocity and acceleration of the locus with the support phase indicated in blue over 96 time steps. The corresponding statistical analysis for these plots can be found in Table 6.3.2.

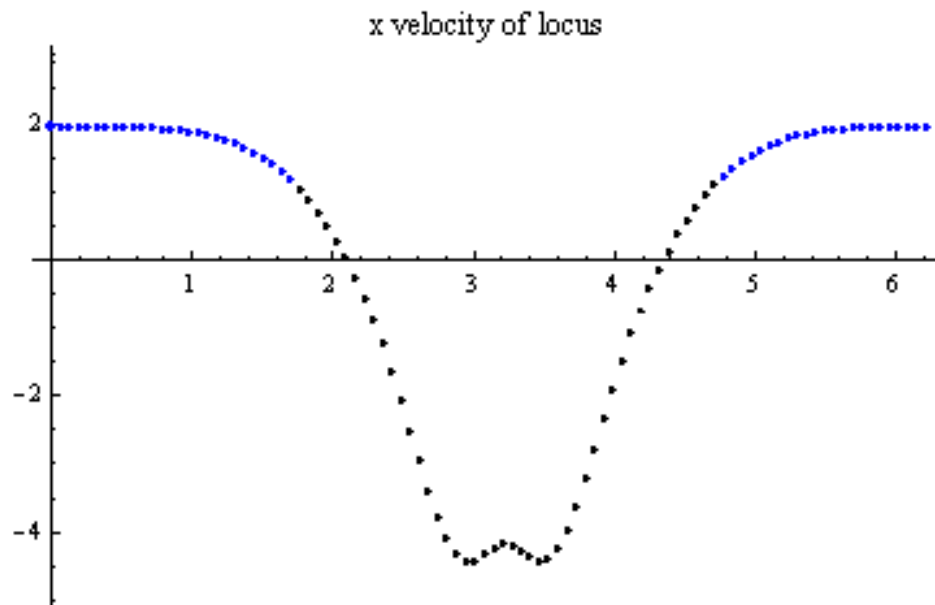

Figure 6.3.6: x velocity of support phase (blue) and return phase (black) plotted versus position of crank θ over 96 time steps of one locomotive cycle shows slight slowing at beginning and end of support phase.

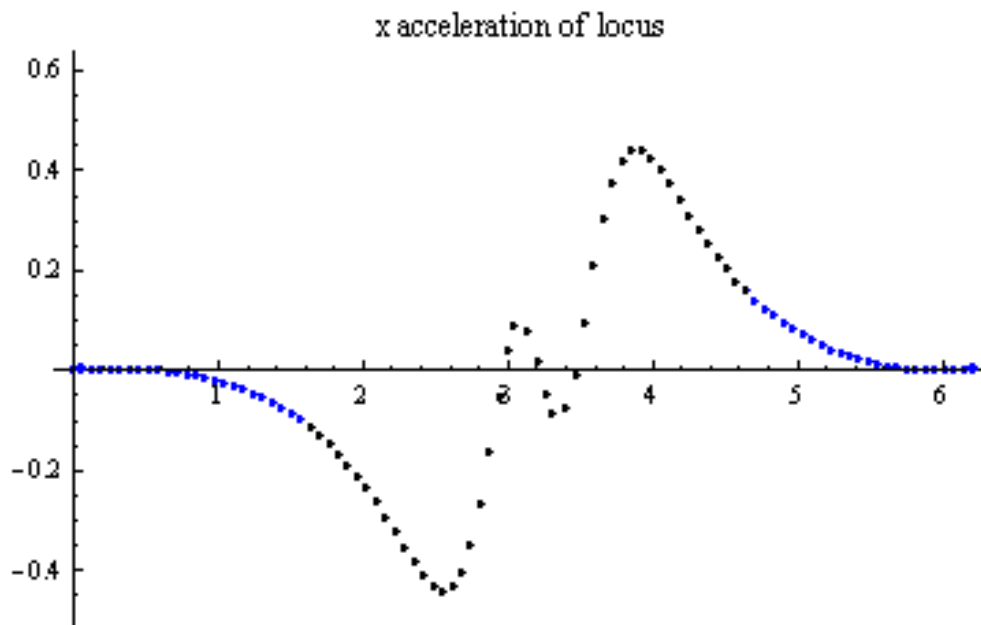

Figure 6.3.7: x acceleration of support phase (blue) and return phase (black) plotted versus position of crank θ over 96 time steps of one locomotive cycle slight deviations from zero at beginning and end of support phase.

Similarly to the Theo Jansen mechanism, this locus has a slight lift at the center of the support phase. However, the standard deviation of this inconsistency accounts for only about 1% of the total step height of the locus and can therefore be considered negligible compared to the scale of fabrication error (see section 7.3). Table 6.3.2 gives an analysis of the Mathematica parameters used in this part of the analysis; in section 6.6 these results will be normalized so that they may be compared to the Theo Jansen locus.

Table 6.3.2: Analysis of support phase (not normalized)

	Y position	X velocity	X acceleration
Minimum	-95.0	----	-----
Mean	94.3	1.8	0.001
Standard Deviation	0.3	0.2	0.04 (standard deviation from zero)

6.4 Center of Mass

Using the same method described in section 3.3.5, I determined the center of mass of each of the rigid bodies of the optimized mechanism and was able to calculate the total center of mass of the leg for an entire locomotive cycle. Figure 6.4.1 shows the resulting plots of each of the component centers of mass. Figure 6.4.2 shows the total center of mass of the mechanism plotted over one full locomotive cycle.

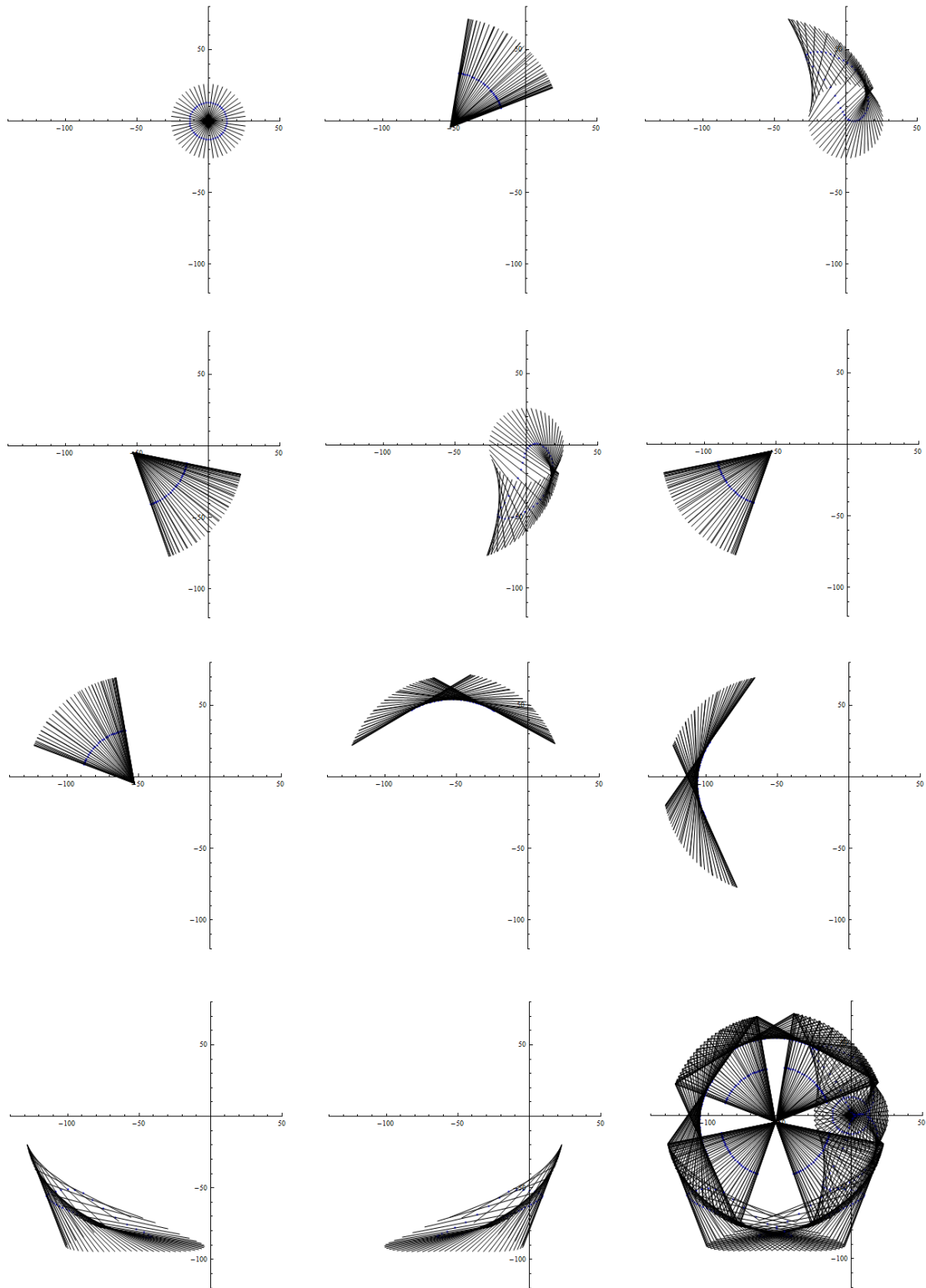

Figure 6.4.1: Center of mass plots for each rigid body over 48 time steps of locomotive cycle. Center of mass is shown in blue. The last plot shows the full linkage with the center of mass of each component part plotted in blue.

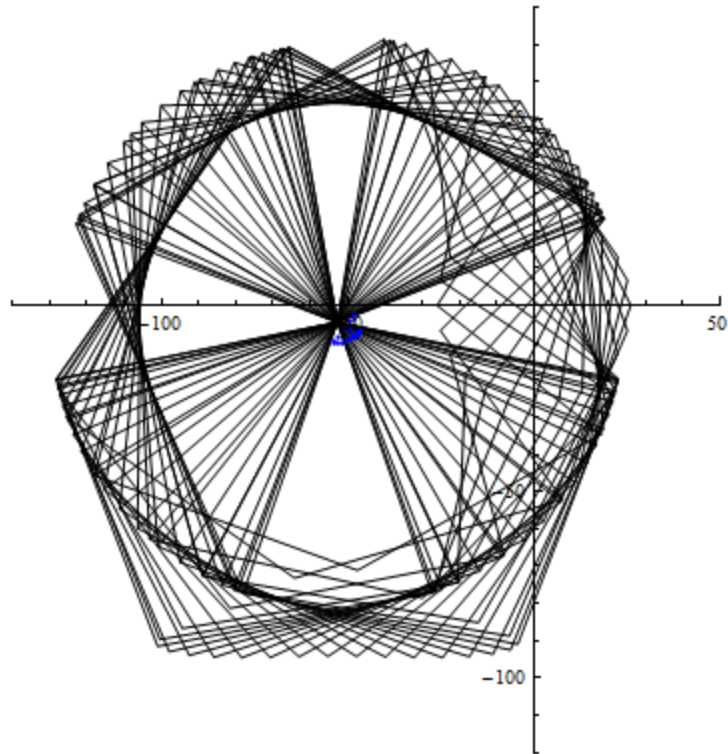

Figure 6.4.2: Total center of mass of one leg plotted for twenty four time steps of a complete locomotive cycle.

6.5 Analysis of Linkage Pair

Following directly from the reasoning described in section 3.3.6, this section will deal with the analysis of a complete linkage pair as well as a set of three pairs of legs with a phase difference of 120° . Figure 6.5.1 shows a pair of legs plotted on the same axis for 12 time steps. It is evident from the plot that a pair of legs cannot exist in the same plane because they will run into each other several times throughout one locomotive cycle. This means that the legs must be slightly offset from one another in the z dimension (extending out from the plane of the paper) if they are to be fabricated.

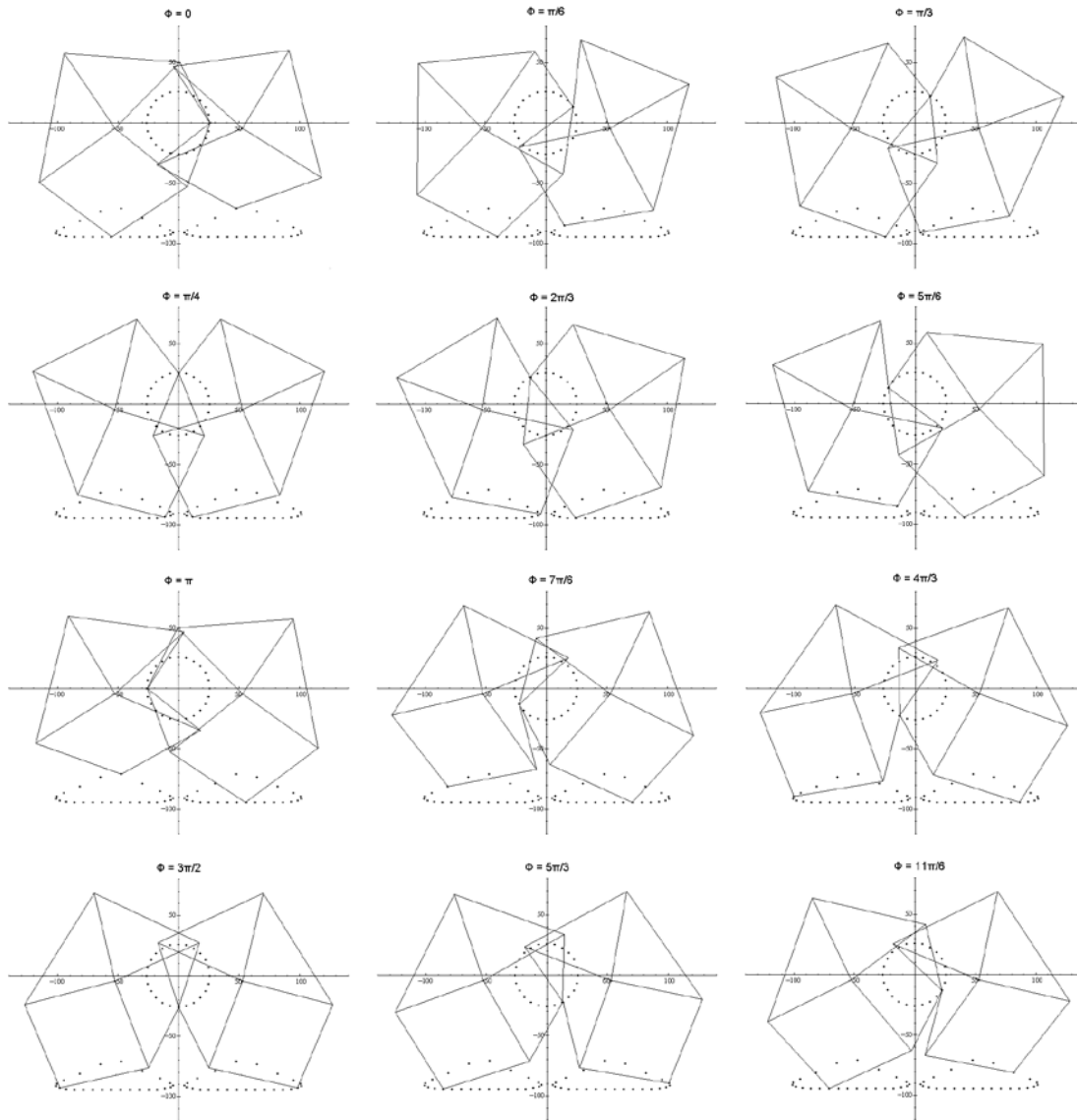

Figure 6.5.1: A pair of legs plotted over twelve time steps spanning an entire locomotive cycle. Position ϕ of crank is indicated in titles.

Figure 6.5.2 shows the total center of mass of a pair of legs plotted over an entire locomotive cycle. By pairing the legs, the total CM has less movement in both the x and y directions. Figure 6.5.3 and 6.5.4 show how 120° phasing of three leg pairs reduces the overall movement of the CM of the walker significantly (50-75%). The position of this six legged walker CM is plotted in Figure 6.5.5.

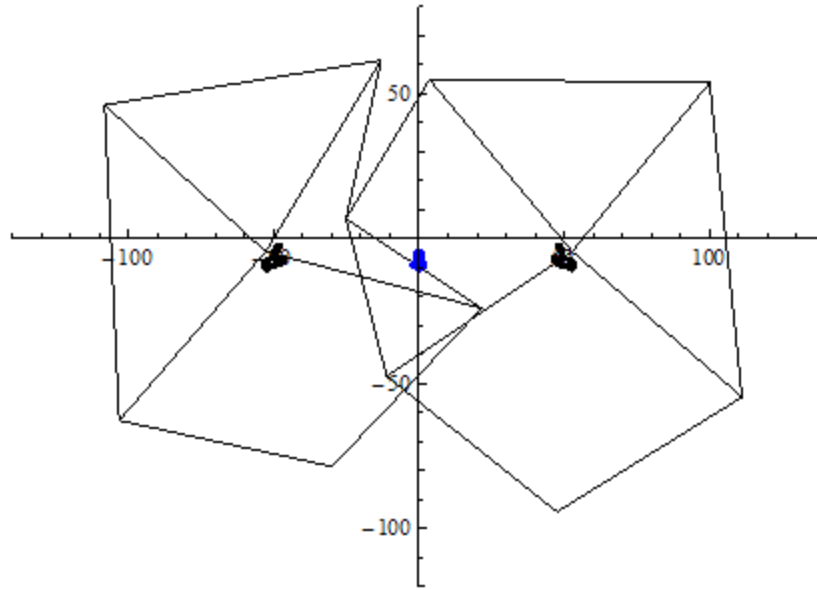

Figure 6.5.2: Total CM of leg pair (blue) plotted with contributing CMs of each leg (black) for 48 time steps of a complete locomotive cycle. Example of linkage pair is shown for reference.

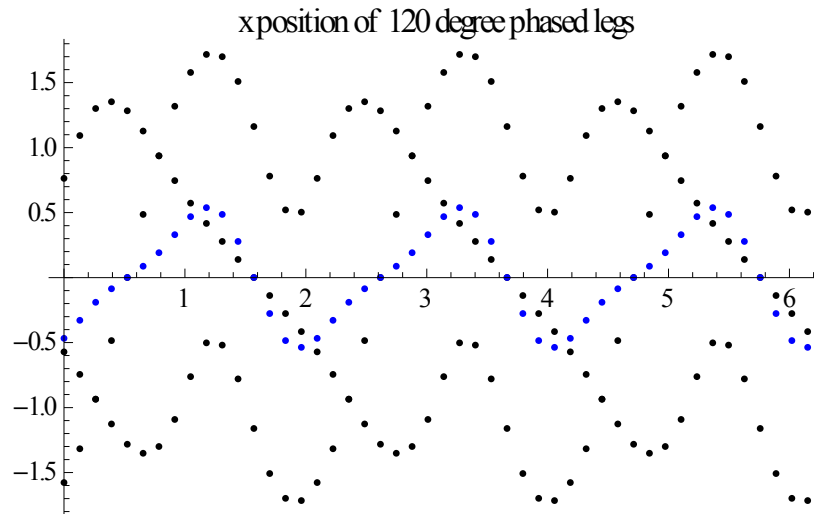

Figure 6.5.3: 120° phasing of three leg pairs in six legged walker. Contributions from each pair are shown in black and x position of total CM of walker is shown in blue for one complete locomotive cycle.

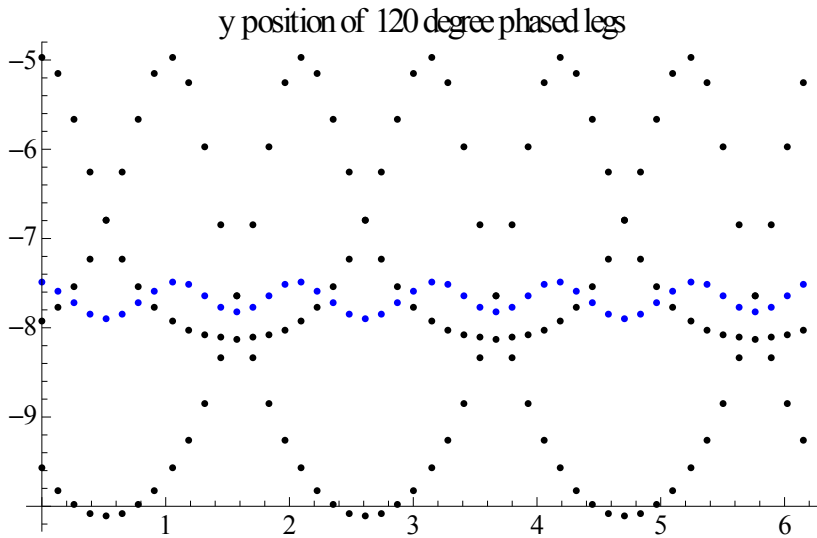

Figure 6.5.4: 120° phasing of three leg pairs in six legged walker. Contributions from each pair are shown in black and y position of total CM of walker is shown in blue for one complete locomotive cycle.

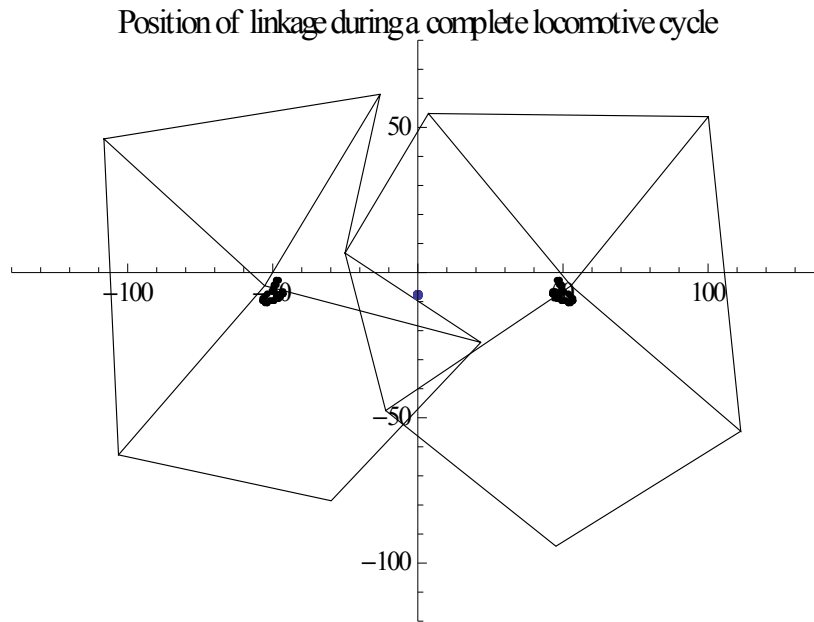

Figure 6.5.5: Total CM of six legged walker with 120° phasing of three leg pairs (blue) plotted with contributing CMs of individual legs (black) for 48 time steps of a complete locomotive cycle. Example of linkage pair is shown for reference.

Table 6.3.3 gives a brief qualitative summary of the effect of pairing and 120° phasing of leg pairs on the magnitude of movement of the CM over a complete locomotive cycle. These results will be normalized and compared to the Theo Jansen results from section 3.3.3 in the following section.

Table 6.3.3: CM Analysis (not normalized)

CM Y deviation (one leg)	7.7
CM X deviation (one leg)	6.9
CM Y deviation (leg pair)	5.1
CM X deviation (leg pair)	3.4
CM Y deviation (three leg pairs)	0.4
CM X deviation (three leg pairs)	1.1

6.6 Comparison with Theo Jansen Mechanism

In order to compare the locus of the Theo Jansen mechanism with my locus, I normalized both linkages in Mathematica so that the length of their strides was equal to 1. I determined the stride length by calculating the difference between the maximum and minimum x coordinate of each locus and normalized the linkage by dividing every parameter by this number.

Table 6.6.1 compares my optimized locus and the Theo Jansen optimized locus according to several parameters of interest. Additionally, Figure 6.6.1 shows both loci (normalized to their stride length) graphically overlaid on top of one another for comparison. The stride phase of my locus is both flatter and has a more constant velocity than the Theo Jansen Mechanism. The normalized standard deviation of the y position of the stride phase of my locus is more than 50% smaller than that of the Theo Jansen locus, although, as I have argued in section 3.3, the deviations in the y position are so small that any gains in flatness are negligible. The normalized standard deviation of the x velocity of my locus is also 50% smaller than that of the Theo Jansen mechanism. The normalized mean velocities of the stride phases of both mechanisms are comparable; the Theo Jansen stride is about 4% faster. Although my locus is more symmetric across the y axis, the Theo Jansen locus has a normalized step height that is about 33% higher. The normalized length of the crank shafts in my design is about 21% larger. The x and y deviations of the center of mass are consistently lower in my design; in fact the y deviations of the CM of the full six legged walker are more than 85% smaller in my design. Overall, the greatest advantages of my new design over the Theo Jansen mechanism are its small CM movement and more constant x velocity. The greatest advantages of the Theo Jansen mechanism are the increased step height and ability to put a linkage pair in the same plane.

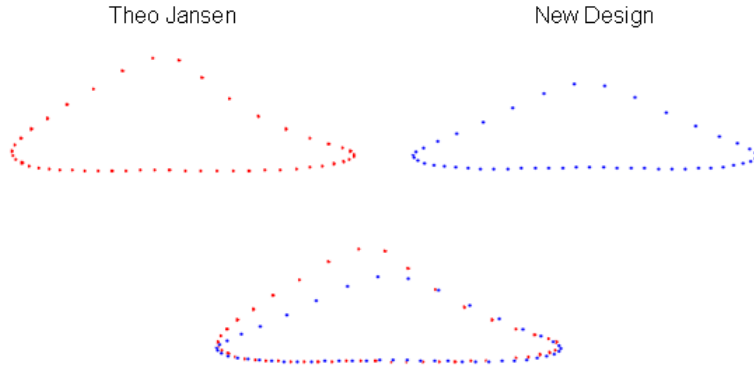

Figure 6.6.1: Comparison of Theo Jansen locus (red) and my locus (blue). Both loci have been normalized to their respective stride lengths. Notice how the step height of the Theo Jansen mechanism is higher when the loci have been normalized this way.

Table 6.6.1: Analysis of Normalized Loci

	Theo Jansen Mechanism	New Design
Normalized Stride Length	1	1
Normalized Step Height	0.33	0.2491
Normalized Standard Deviation of y position	0.0070	0.0030
Normalized Mean x Velocity	0.020	0.01871
Normalized Standard Deviation of x Velocity	0.0036	0.0018
Normalized crank radius	0.22	0.2682
Normalized CM Y deviation (one leg)	0.14	0.079
Normalized CM X deviation (one leg)	0.36	0.071
Normalized CM Y deviation (leg pair)	0.064	0.053
Normalized CM X deviation (leg pair)	0.31	0.035
Normalized CM Y deviation (three leg pairs)	0.031	0.0041
Normalized CM X deviation (three leg pairs)	0.018	0.011

Table 6.6.2: Summary of Linkage Comparison

Theo Jansen Mechanism Advantages	New Design Advantages
<ul style="list-style-type: none">• Step height 33% higher• 4% faster stride• Pair of legs may occupy same plane	<ul style="list-style-type: none">• Standard deviation of stride height is 50% lower• Standard deviation of stride x velocity is 50% lower• Locus is symmetric across the y axis• 85% less CM movement during locomotion

Chapter 7: Construction and Conclusions

7.1 Introduction

The final step of this project was to implement my leg design in a real life six legged walker made primarily out of PVC pipe. I chose to scale every 25 units of length in my Mathematica simulations to 1 foot. I chose this because it was the largest size I could build using the 10 foot sections of PVC that were available to me; I wanted to build the walker as large as possible so that I would minimize the percent error in my measurements.

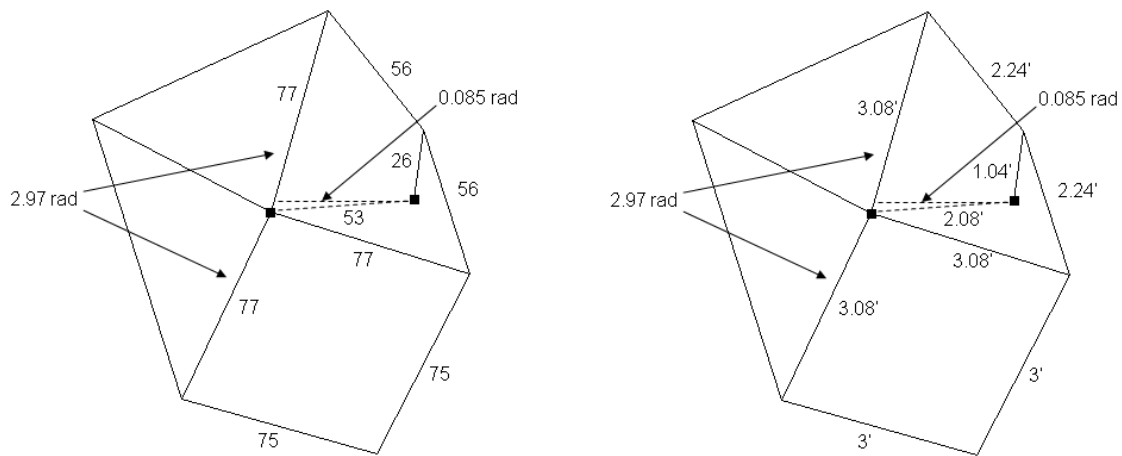

Figure 7.1.1: Optimized mechanism with Mathematica units on left and units of feet on right. Scale is 25 Mathematica units to 1 foot.

7.2 Construction

7.2.1 Materials

I used three types of 10' PVC pipe to construct my walking mechanism: 1" schedule 20, 1" schedule 40, and 1 1/4" schedule 40. All are picture in Figure 7.2.1. I used the 1" schedule 20 pipe all the structural parts of the walker because it is inexpensive, its thinner walls were easier to heat treat and bend, and because it's light weight and rigid enough for my purposes. I used the schedule 40 PVC pipe for the hinges of my walker because their thicker walls gave them extra structural stability. Additionally, the 1" schedule 40 pipe fits inside the 1 1/4" schedule 40 pipe with only about 1-2mm of extra space (Figure 7.2.2), making the pair of pipes ideal for the construction of a freely rotating hinge.

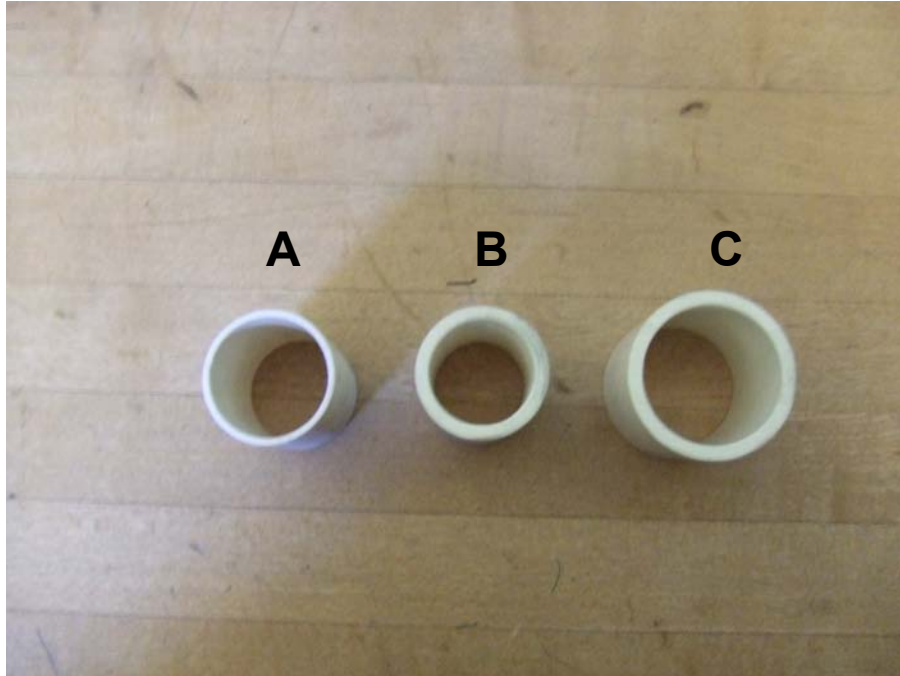

Figure 7.2.1: A 1" schedule 20 PVC pipe, B 1" schedule 40 PVC pipe, C 1 1/4" schedule 40 PVC pipe.



Figure 7.2.2: The 1" schedule 40 pipe fits inside the 1 1/4" schedule 40 pipe with only 1-2mm of free space. This type of fit was ideal for my hinge design (described in section 7.2.3).

I used both 8" and 11" zip ties to fasten the majority of the structural components. I used a zip tie gun to pull the zip ties tight and cut to size. Both the gun and the ties are shown below.



Figure 7.2.3 8" and 11" zip ties with zip tie gun.

7.2.2 Rigid Bodies

In order to ensure accuracy of linkage lengths in the construction of the legs, I used three jigs to construct all the rigid bodies. Each of the jigs was constructed with a wood frame and $1\frac{1}{4}$ " (inner diameter) steel water pipe. The outer diameter of the pipe is equal to the outer diameter of the $1\frac{1}{4}$ " schedule 40 PVC tube. The pipe was installed in the wood frame so that the distance of the center of one piece of water pipe to the center of the other pipe was equal to the exact length of a rigid body in my mechanism. Figures 7.2.4, 7.2.5 and 7.2.6 show the three jigs with center to center pipe distances indicated.

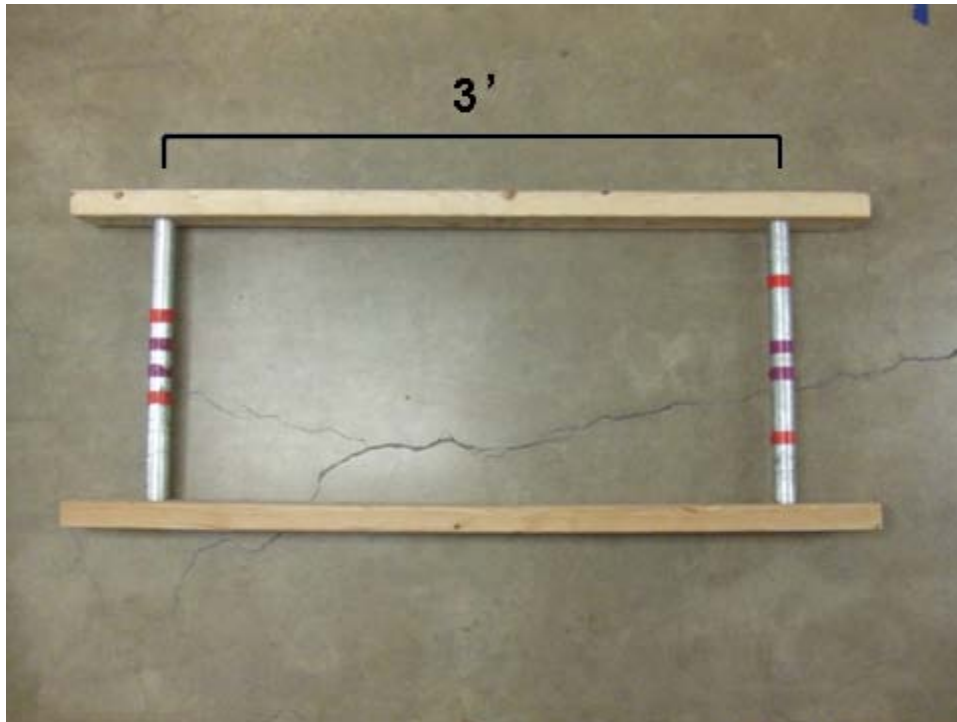

Figure 7.2.4: 3 foot jig.

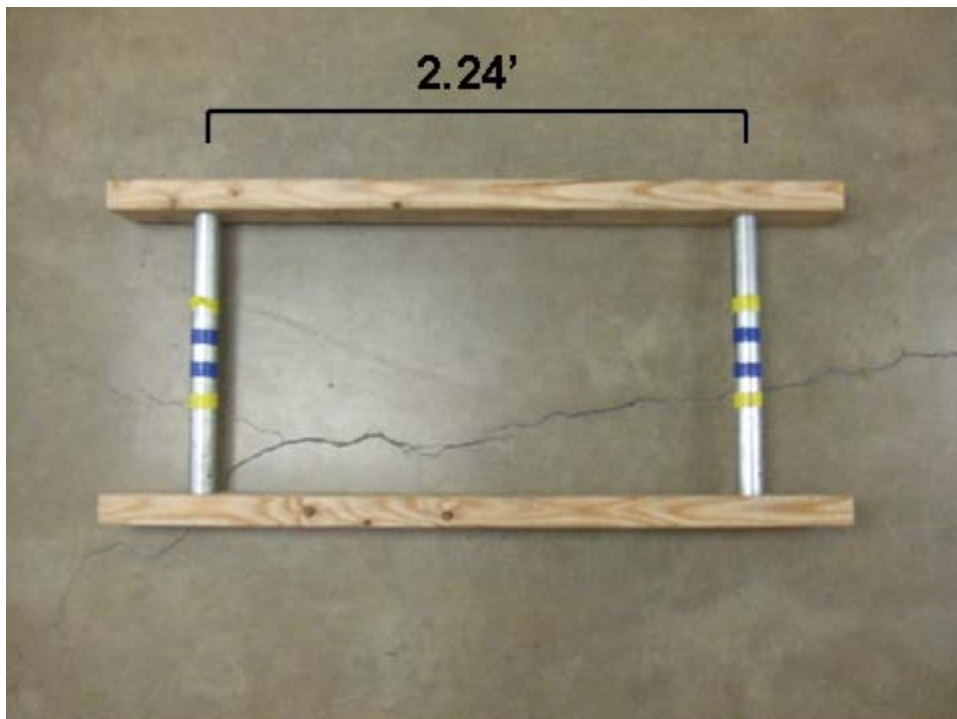

Figure 7.2.5: 2.24 foot jig



Figure 7.2.6: Jig for creating 2.97 radian displacement section and 3.08 foot sections.

Figures 7.2.8 through 7.2.13 show each of the six rigid bodies of one entire leg in their respective jigs. Each piece was constructed from 1" schedule 20 PVC, which was heated with a heat gun at 500 degrees F in a well ventilated space until it became malleable enough to bend and tie to the jig with zip ties. Care was taken to make sure that the bends of the rigid body pieces were tied tight enough to the pipe so that they formed to the curvature of the water pipe. Once cool, the zip ties fastening the PVC to the steel pipe were cut and the PVC piece was removed from the jig. The naming system of each of the pieces of the leg is shown below:

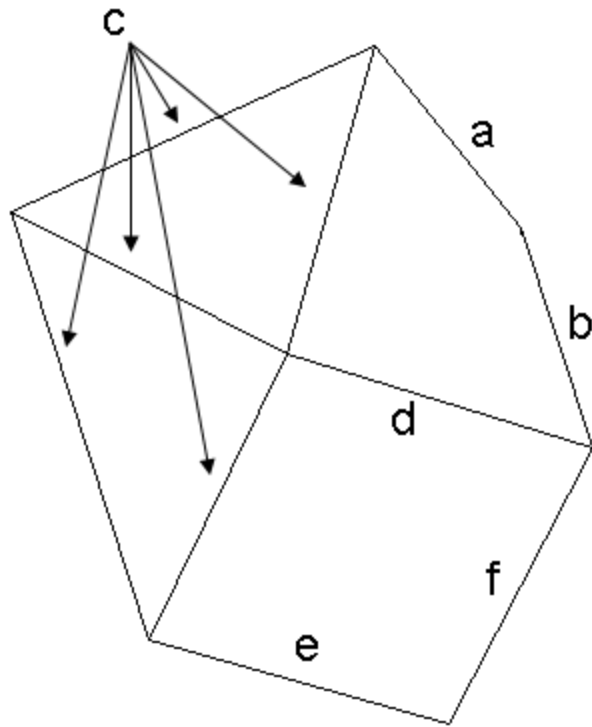

Figure 7.2.7: Naming system of each of the six leg pieces.



Figure 7.2.8: Leg part e.

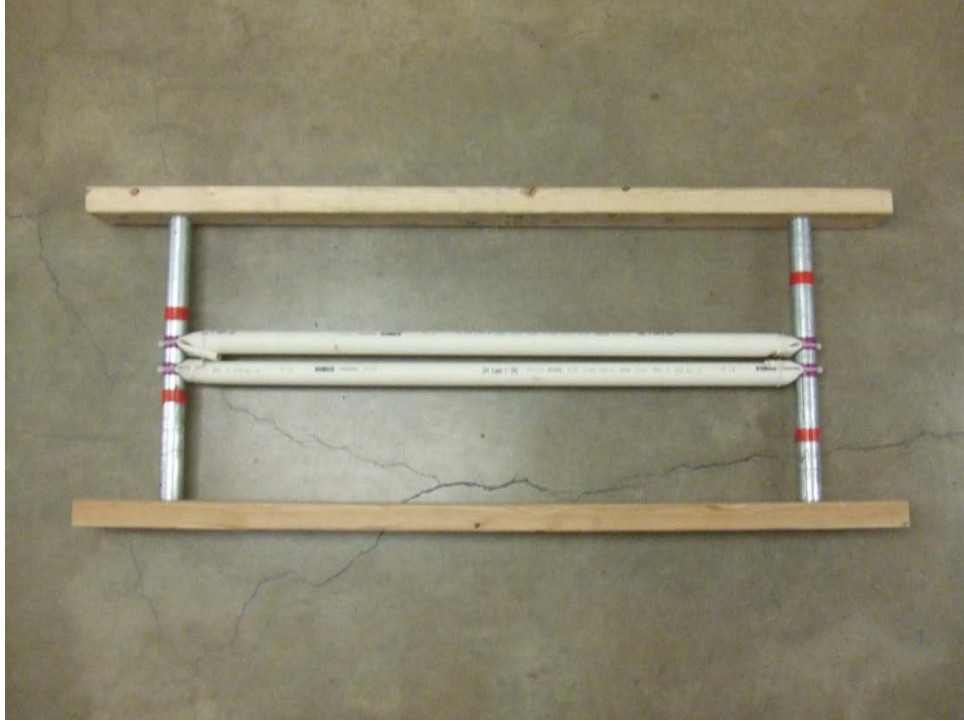

Figure 7.2.9: Leg part f



Figure 7.2.10: Leg part a.



Figure 7.2.11: Leg part b.

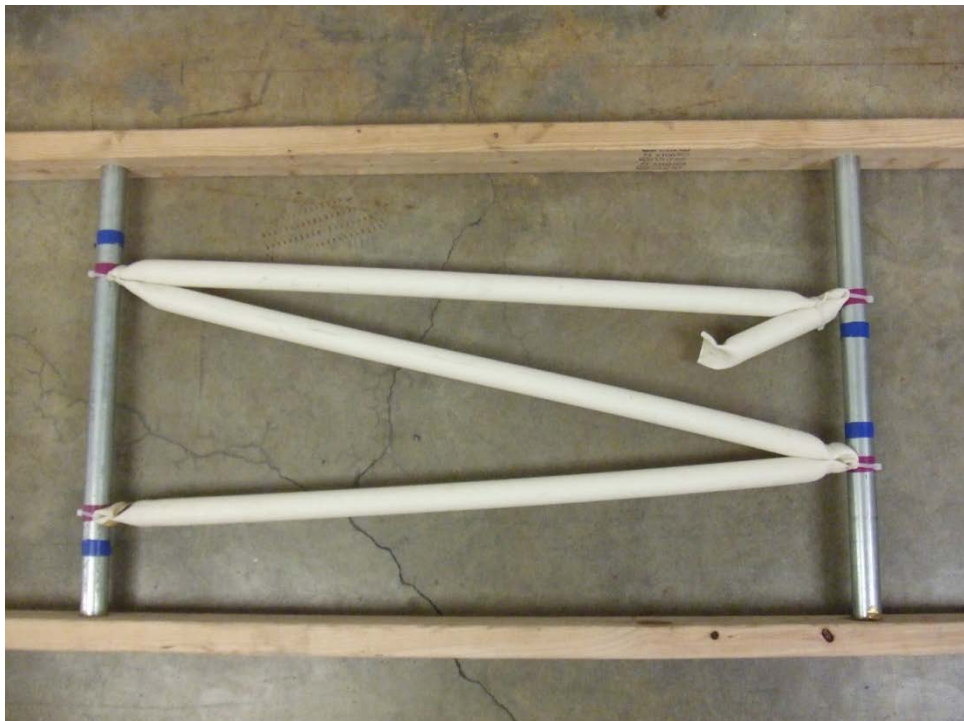

Figure 7.2.12: Leg part d.



Figure 7.2.13: Leg part c.

7.2.3 Hinges

The moving part of the hinges was made from short segments of schedule 40 1 1/4 inch diameter PVC that had been formed to a shape that could more easily attach to the rigid segments from the previous section. A section of schedule 40 1" PVC was threaded through these moving hinge parts so that they would rotate along the same axis.

The first step in creating the moving hinge parts was to cut 1 1/2 inch sections of schedule 40 1 1/4 inch diameter PVC pipe on the band saw (Figure 7.2.14). The fringes were removed from the edges of the cut pieces using a pair of PVC strippers (Figures 7.2.15 and 7.2.16).



Figure 7.2.14: cutting equal 1 ½ inch segments of 1 ¼ inch schedule 40 PVC on the band saw.



Figure 7.2.15: Short section of PVC tube cut on band saw.



Figure 7.2.16: Short section of PVC pipe cut on band saw with fringes removed.

The short sections of pipe were then placed in an oven in groups of four and heated at 410 degrees F for four minutes (Figure 7.2.17 and 7.2.18). Under a fume hood, the pieces of heated PVC (Figure 7.2.19) were taken out of the oven individually and pressed in an aluminum jig (Figures 7.2.20 and 7.2.21).



Figure 7.2.17: PVC sections being loaded into the oven in groups of four.



Figure 7.2.18: Oven set to 410 degrees F. Heat pipe for four minutes (with oven door closed).



Figure 7.2.19: Heated PVC is malleable and can be formed into a variety of shapes, but still maintains most of its original structure.



Figure 7.2.21: PVC section in jig before pressing.



Figure 7.2.22: PVC section in jig after pressing.

The jig is shown by itself in Figure 7.2.23; it consists of two angled sections cut to a 40 degree pitch and a $\frac{3}{4}$ inch spacer. A metal pin keeps the pieces of the jig centered during pressing. The heated PVC was pressed for about thirty seconds or until it had

cooled to a point where it would hold its shape. During the pressing I placed the jig and PVC on the floor and stepped on the top of the jig, using my own body weight to stretch and bend the PVC on the jig. The PVC was then removed from the jig and allowed to cool back to room temperature.



Figure 7.2.23: Hinge pressing jig with measurements and pitch indicated.

The final product of the pressing is shown in the figure below next to an unpressed section of tube. The inner diameter of the pressed pieces of pipe was about 1.05 inches; enough to allow them to rotate freely around a 1 inch diameter section of pipe with little friction, but not enough to cause instability.



Figure 7.2.24: Pressed and unpressed PVC pipe.

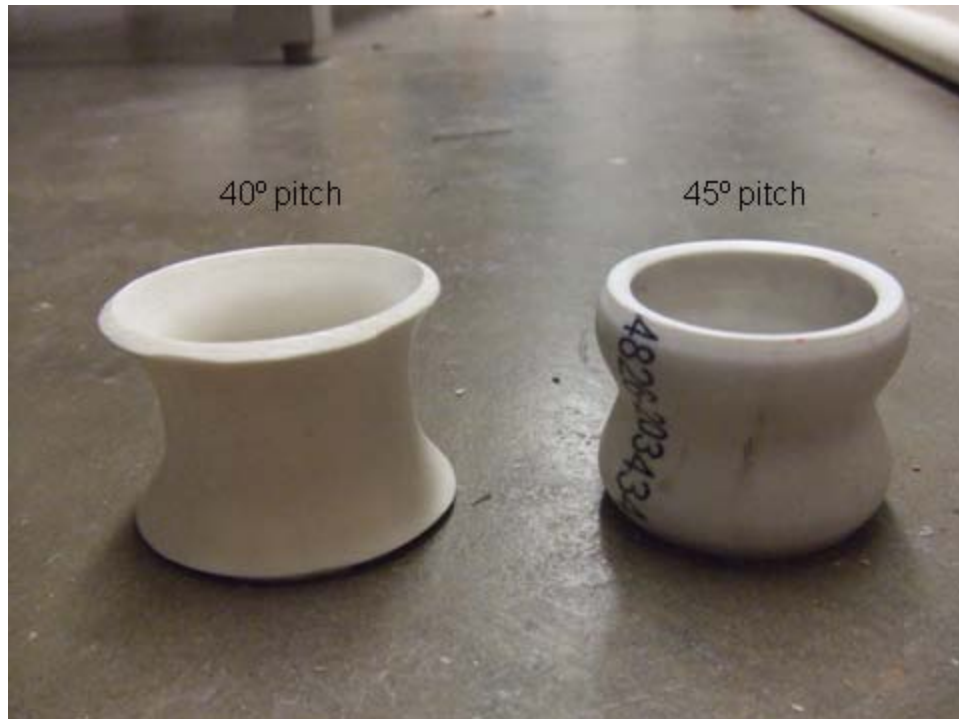

Figure 7.2.25: Bowing occurred when we tried increasing the pitch of the press from 40 to 45 degrees.

To construct the hinges, I cut a piece of 1" schedule 40 pvc to fit inside the pressed pieces (Figure 7.2.26). By slightly flaring out each end of the inner pvc tube, I was able to lock the pressed hinge pieces onto a pipe so that they all rotate around the same axis. Three example hinges are shown in Figure 7.2.27.



Figure 7.2.26: 1" schedule 40 PVC fits inside pressed hinge piece with enough room for rotation.



Figure 7.2.27: Three types of hinges, all are held together by a section of 1" schedule 40 pipe. A piece of 1 1/4" schedule 40 PVC pipe is used as a spacer in the largest hinge.

By attaching the rigid bodies to the rotating hinges with zip ties, I was able to create a hinge which is rotates freely in one plane. An example hinge is demonstrated in Figure 7.2.28.



Figure 7.2.28: Rigid bodies attached to hinge with zip ties so that they are constrained to planar rotation.

7.3 Comparison with theoretical model

The technique I used to fabricate the six legged walker caused all of the linkages to measured slightly larger than my theoretical model. Although I bent the PVC around metal pipe that matched the outer diameter of the hinge pieces, any small inconsistencies caused the pieces to fit together less tightly, thus, increasing the overall length of the linkage parts. Table 7.3.1 summarizes the error that I found in one leg of the walker compared to the theoretical model. As expected, the error in the linkage lengths is always high, usually around 1-2% increase in length.

Table 7.3.1: Comparison of Actual Linkage Lengths with Theoretical Model

Part Name	Theoretical Dimensions (Feet or Radians)	Actual Dimensions (Feet or Radians)	Error (Inches or Radians)	Percent Error
Crank Radius	1.04'	1.05'	0.12"	+0.96%
A	2.24'	2.29'	0.6"	+2.2%
B	2.24'	2.29'	0.6"	+2.2%
D	3.08'	3.13'	0.6"	+1.6%
E	3'	3.05'	0.6"	+1.7%
F	3'	3.05'	0.6"	+1.7%
C (Upper Section)	3.08'	3.13'	0.6"	+1.6%
C (Lower Section)	3.08'	3.13'	0.6"	+1.6%
C (Angle)	2.97 rad	3 rad	0.03 rad	+1.0%
Crank Axis to Fixed Hinge	2.08'	2.12'	0.48"	+1.9%
Crank Axis to Fixed Hinge (Angle)	0.085 rad	0.083 rad	-0.002 rad	-2.4%

I plugged in the actual measurements of the leg into Mathematica to see how much the locus would be affected by the error in the fabrication process. The results are shown in Figure 7.3.1.

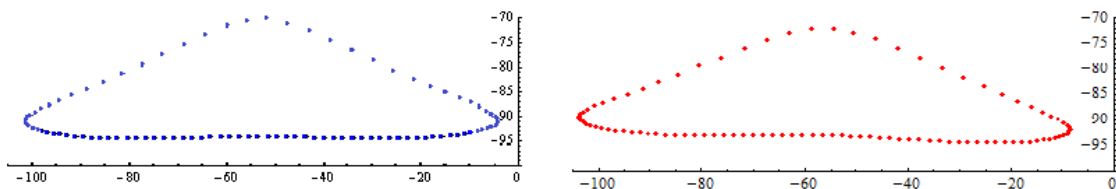

Figure 7.3.1: Comparison of theoretical locus (blue) and locus based on fabricated leg (red) shows that the overall shape of the locus is not affected significantly. The fabricated leg locus is turned slightly clockwise.

7.4 Possible Improvements/ Future Work

Currently, the full six legged walker has only been assembled once; this assembly is shown in Figure 7.4.1. Unfortunately, excess bowing in the frame caused the walker to be so unstable that it could not stand on its own. Additionally, the bowing in the frame put excess pressure on the hinges of the legs, which caused some of the zipties to stretch and break. In the future I will rebuild the frame using four ten foot metal conduit pipes as the main axial supports. I may also reinforce some of the leg hinges with 1/8" nylon rope if the stability of the hinges continues to be a problem. Eventually, I would like to attach a wind turbine to the central crank axis and attempt to power the walker with the wind.



Figure 7.4.1: Pomona Physics and Astronomy Department assembling six legged walker on Marston Quad.

Appendix A: Mathematica Code

This appendix contains the Mathematica code I used to generate all the plots and quantitative analysis in this paper. The first few sections are heavily commented, the last sections are less commented, but follow directly from the comments in the first sections.

```
Remove["Global`*"] (*remove saved variables*)
```

```
(*SOLVING AND PLOTTING POSITION OF THEO JANSEN MECHANISM*)
```

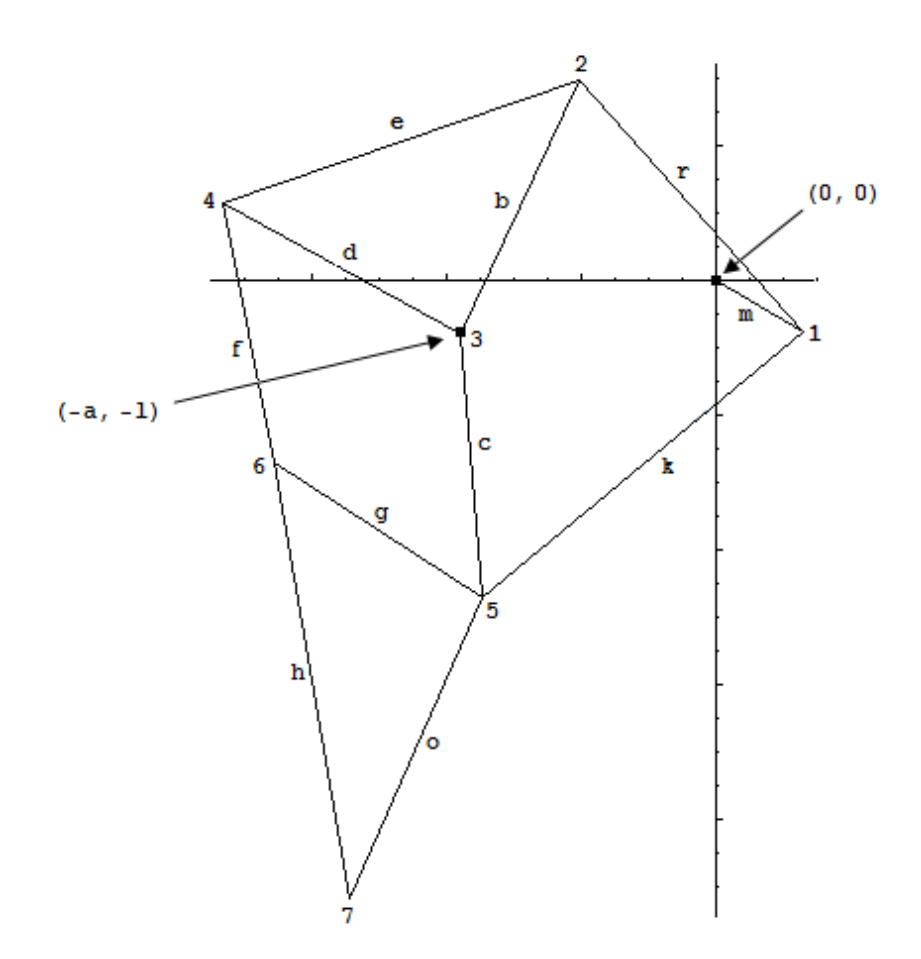

```
(*define variables*)
```

```
a = 38;  
b = 41.5;  
c = 39.3;
```

```

d = 40.1;
e = 55.8;
f = 39.4;
g = 36.7;
h = 65.7;
o = 49;
r = 50;
k = 61.9;
l = 7.8;
m = 15;
step = 48; (*number of time steps*)
example = 45; (*time step of full linkage plots*)

(*position of crank*)
xone[phi_] := m * Cos[phi];
yone[phi_] := m * Sin[phi];
x1 = ParallelTable[{xone[2 * (i - 1) * Pi / step], yone[2 * (i - 1) * Pi / step]}, {i, step}];
crank = ListPlot[x1, PlotLabel → "position of crank", AspectRatio → Automatic,
  PlotRange → {{-120, 30}, {-100, 40}}, PlotStyle → RGBColor[0, 0, 0]]
(*Plot of position of crank for one locomotive cycle*)

(*position of fixed point 3*)
xthree = -a;
ythree = -1;

(*position of point two*)
xtwo[thetaone_] := xthree + b * Cos[thetaone];
ytwo[thetaone_] := ythree + b * Sin[thetaone];
s := ParallelTable[
  Solve[
    {r^2 == (xtwo[z] - xone[2 * (i - 1) * Pi / step])^2 + (ytwo[z] - yone[2 * (i - 1) * Pi / step])^2},
    z], {i, step}]; (*solve equation for theta 1 for all time steps*)
z2 = z /. s;
z20 = Flatten[z2]; (*de-nest solutions*)
z2o = Select[z20, 0 < # < Pi &]; (*remove extraneous solutions*)
positiontwo = ListPlot[Thread[{xtwo[z2o], ytwo[z2o]}], PlotLabel → "position two",
  AspectRatio → Automatic, PlotRange → {{-120, 30}, {-100, 40}}, PlotStyle → RGBColor[0, 0, 0]]
(*position plot for entire locomotive cycle*)

ListPlot[{z2o}, PlotLabel → "theta one", PlotStyle → RGBColor[0, 0, 0]]
(*theta 1 plot for entire locomotive cycle*)

ListPlot[{xtwo[z2o]}, PlotLabel → "x two", PlotStyle → RGBColor[0, 0, 0]]
(*x position plot for entire locomotive cycle*)

ListPlot[{ytwo[z2o]}, PlotLabel → "y two", PlotStyle → RGBColor[0, 0, 0]]
(*y position plot for entire locomotive cycle*)

```

(*note: solving for the position of points four, five, and six follows the same method used for point two*)

(*position of point five*)

```

xfive[thetatwo_] := xthree + c * Cos[thetatwo];
yfive[thetatwo_] := ythree + c * Sin[thetatwo];
s1 := ParallelTable[
  Solve[{k^2 == (xfive[y] - xone[2 * (i - 1) * Pi / step])^2 +
    (yfive[y] - yone[2 * (i - 1) * Pi / step])^2}, y], {i, step}];
y2 = y /. s1;
y20 = Flatten[y2];
y2o = Select[y20, -Pi < # < -Pi / 4 &];
positionfive = ListPlot[Thread[{xfive[y2o], yfive[y2o]}], PlotLabel -> "position five",
  AspectRatio -> Automatic, PlotRange -> {{-120, 30}, {-100, 40}}, PlotStyle -> RGBColor[0, 0, 0]]

ListPlot[{y2o}, PlotLabel -> "theta two", PlotStyle -> RGBColor[0, 0, 0]]

ListPlot[{xfive[y2o]}, PlotLabel -> "x five", PlotStyle -> RGBColor[0, 0, 0]]

ListPlot[{yfive[y2o]}, PlotLabel -> "y five", PlotStyle -> RGBColor[0, 0, 0]]

```

(*position of point four*)

```

xfour[thetathree_] := xthree + d * Cos[thetathree];
yfour[thetathree_] := ythree + d * Sin[thetathree];
s2 := ParallelTable[
  Solve[
    {e^2 == (xfour[x] - xtwo[Extract[z2o, {i}])^2 + (yfour[x] - ytwo[Extract[z2o, {i}])^2},
    x], {i, step}];
x2 = x /. s2;
x20 = Flatten[x2];
x2o = Select[x20, Cos[#] < 0 &];
positionfour = ListPlot[Thread[{xfour[x2o], yfour[x2o]}], PlotLabel -> "position four",
  AspectRatio -> Automatic, PlotRange -> {{-120, 30}, {-100, 40}}, PlotStyle -> RGBColor[0, 0, 0]]

ListPlot[{x2o}, PlotLabel -> "theta three", PlotStyle -> RGBColor[0, 0, 0]]

ListPlot[{xfour[x2o]}, PlotLabel -> "x four", PlotStyle -> RGBColor[0, 0, 0]]

ListPlot[{yfour[x2o]}, PlotLabel -> "y four", PlotStyle -> RGBColor[0, 0, 0]]

```

(*position of point six*)

```

s3 := ParallelTable[
  Solve[{g^2 == (xfour[Extract[x2o, {i}]] + f * Cos[w] - xfive[Extract[y2o, {i}]])^2 +
    (yfour[Extract[x2o, {i}]] + f * Sin[w] - yfive[Extract[y2o, {i}]])^2}, w], {i, step}];
w2 = w /. s3;
w20 = Flatten[w2];
w2o = Select[w20, -Pi < # < -Pi / 4 &];
positionsix = ListPlot[Thread[{xfour[x2o] + f * Cos[w2o], yfour[x2o] + f * Sin[w2o]}],
  PlotLabel -> "position six", AspectRatio -> Automatic,

```

```

PlotRange → {{-120, 30}, {-100, 40}}, PlotStyle → RGBColor[0, 0, 0]]

ListPlot[{w2o}, PlotLabel → "theta four", PlotStyle → RGBColor[0, 0, 0]]

ListPlot[{xfour[x2o] + f * Cos[w2o]}, PlotLabel → "x six",
PlotStyle → RGBColor[0, 0, 0]]

ListPlot[{yfour[x2o] + f * Sin[w2o]}, PlotLabel → "y six", PlotStyle → RGBColor[0, 0, 0]]

(*position of foot*)
s4 := ParallelTable[
  Solve[{o^2 == (xfive[Extract[y2o, {i}]] - xseven)^2 + (yfive[Extract[y2o, {i}]] - yseven)^2,
    h^2 == (xfour[Extract[x2o, {i}]] + f * Cos[Extract[w2o, {i}]] - xseven)^2 +
    (yfour[Extract[x2o, {i}]] + f * Sin[Extract[w2o, {i}]] - yseven)^2},
    {xseven, yseven}], {i, step}]; (*solve system of equations
for x and y positions of foot for all time steps*)
y7 = yseven /. s4; (*it is easy to pick out the extraneous
solutions by looking at their y coordinates first*)
y7o = Flatten[y7]; (*de-nest solutions*)
y7o = Select[y7o, # < -25 &]; (*remove extraneous solutions*)
s5 := ParallelTable[Solve[{o^2 - h^2 == (yfive[Extract[y2o, {i}]] - Extract[y7o, {i}])^2 -
  (yfour[Extract[x2o, {i}]] + f * Sin[Extract[w2o, {i}]] - Extract[y7o, {i}])^2 +
  (xfive[Extract[y2o, {i}]] )^2 - 2 * xfive[Extract[y2o, {i}]] * xseven -
  (xfour[Extract[x2o, {i}]] + f * Cos[Extract[w2o, {i}]] )^2 + 2 *
  (xfour[Extract[x2o, {i}]] + f * Cos[Extract[w2o, {i}]] ) * xseven}, xseven], {i, step}];
(*plug in correct y solutions and solve again for x positions
for
all
time
steps*)
x7 = xseven /. s5;
x7o = Flatten[x7]; (*de-nest solutions*)
positionoffoot = ListPlot[Thread[{x7o, y7o}], PlotLabel → "position of foot",
  AspectRatio → Automatic, PlotRange → {{-120, 30}, {-100, 40}}, PlotStyle → RGBColor[0, 0, 0]]
(*plot position of foot for entire locomotive cycle*)

ListPlot[{x7o}, PlotLabel → "x seven", PlotStyle → RGBColor[0, 0, 0]]
(*plot of x position of foot for entire locomotive cycle*)

ListPlot[{y7o}, PlotLabel → "y seven", PlotStyle → RGBColor[0, 0, 0]]
(*plot of y position of foot for entire locomotive cycle*)

leg = ListLinePlot[{{xone[2 * (example - 1) * Pi / step], yone[2 * (example - 1) * Pi / step]},
  {xtwo[Extract[z2o, {example}]], ytwo[Extract[z2o, {example}]}}, {xthree, ythree},
  {xfive[Extract[y2o, {example}]], yfive[Extract[y2o, {example}]}},
  {xone[2 * (example - 1) * Pi / step], yone[2 * (example - 1) * Pi / step]}},
  {{xtwo[Extract[z2o, {example}]], ytwo[Extract[z2o, {example}]}},
  {xfour[Extract[x2o, {example}]], yfour[Extract[x2o, {example}]}}, {xthree, ythree}},
  {{xtwo[Extract[z2o, {example}]], ytwo[Extract[z2o, {example}]}},

```

```

    {xfour[Extract[x2o, {example}]], yfour[Extract[x2o, {example}]]}, {xthree, ythree}},
    {{xfour[Extract[x2o, {example}]], yfour[Extract[x2o, {example}]]},
    {xfour[Extract[x2o, {example}]] + f * Cos[Extract[w2o, {example}]],
    yfour[Extract[x2o, {example}]] + f * Sin[Extract[w2o, {example}]]},
    {xfive[Extract[y2o, {example}]], yfive[Extract[y2o, {example}]]},
    {Extract[x7o, {example}], Extract[y7o, {example}]},
    {xfour[Extract[x2o, {example}]] + f * Cos[Extract[w2o, {example}]],
    yfour[Extract[x2o, {example}]] + f * Sin[Extract[w2o, {example}]]}}},
    PlotStyle → RGBColor[0, 0, 0]; (*plot a diagram
of the linkage for a given time step
specified
by
"example"*)

```

```

ListLinePlot[Flatten[ParallelTable[
  {{xone[2 * (i - 1) * Pi / step], yone[2 * (i - 1) * Pi / step]}, {xtwo[Extract[z2o, {i}]],
  ytwo[Extract[z2o, {i}]]}, {xthree, ythree}, {xfive[Extract[y2o, {i}]],
  yfive[Extract[y2o, {i}]]}, {xone[2 * (i - 1) * Pi / step], yone[2 * (i - 1) * Pi / step]}},
  {{xtwo[Extract[z2o, {i}]], ytwo[Extract[z2o, {i}]]},
  {xfour[Extract[x2o, {i}]], yfour[Extract[x2o, {i}]]}, {xthree, ythree}},
  {{xtwo[Extract[z2o, {i}]], ytwo[Extract[z2o, {i}]]},
  {xfour[Extract[x2o, {i}]], yfour[Extract[x2o, {i}]]}, {xthree, ythree}},
  {{xfour[Extract[x2o, {i}]], yfour[Extract[x2o, {i}]]}, {xfour[Extract[x2o, {i}]] +
  f * Cos[Extract[w2o, {i}]], yfour[Extract[x2o, {i}]] + f * Sin[Extract[w2o, {i}]]},
  {xfive[Extract[y2o, {i}]], yfive[Extract[y2o, {i}]]}, {Extract[x7o, {i}],
  Extract[y7o, {i}]}, {xfour[Extract[x2o, {i}]] + f * Cos[Extract[w2o, {i}]],
  yfour[Extract[x2o, {i}]] + f * Sin[Extract[w2o, {i}]]}}}, {i, 1, step, step / 24}], 1],
PlotStyle → RGBColor[0, 0, 0], AspectRatio → Automatic,
PlotRange →
  {{-120, 30}, {-100, 40}},
PlotLabel → "Position of linkage during a complete locomotive cycle" (*Plot
a
diagram
of
the
linkage
for
24
equally
spaced
time
steps
in
locomotive
cycle
("step" must be an integer multiple of 24 for this to work properly)*)

```

```
Show[{crank, positionoffoot, positiontwo, positionfour, positionfive, positionsix, leg},
PlotRange → {{-120, 30}, {-100, 40}},
PlotLabel → "Theo Jansen mechanism with positions of all hinges"]
(*plot the position of the crank, foot, and points 2-6 for entire locomotive cycle*)
```

```
Show[{crank, positionoffoot, leg},
PlotRange → {{-120, 30}, {-100, 40}}, PlotLabel → "12 of 12"]
(*plot the position of the crank and foot for all time steps with a
diagram of the linkage at the time step specified by "example"*)
```

```
(*SOLVING FOR VELOCITY AND ACCELERATION*)
```

```
step = 48;
crankrate = 2 * Pi / step;
(*let the angular velocity of the crank be constant and =
2*Pi/step for entire locomotive cycle*)
phi = Table[i, {i, 0, (2 Pi - 2 Pi / step), 2 Pi / step}]; (*angular position of crank*)

(*crank*)
xonepos = Flatten[ParallelTable[xone[Extract[phi, {i}]], {i, step}]];
ListPlot[Thread[{phi, xonepos}],
PlotStyle → RGBColor[0, 0, 0], PlotLabel → "x position of point 1"]
xonevel = Flatten[{(1 / 2) * (-Extract[xonepos, {-1}] + Extract[xonepos, {2}]), ParallelTable[
(1 / 2) * (-Extract[xonepos, {i - 1}] + Extract[xonepos, {i + 1}]), {i, 2, step - 1}],
(1 / 2) * (-Extract[xonepos, {step - 1}] + Extract[xonepos, {1}])}]; (*slope of xonepos*)
ListPlot[Thread[{phi, xonevel}], PlotStyle → RGBColor[0, 0, 0],
PlotLabel → "x velocity of point 1"]
xoneacc = Flatten[{(1 / 2) * (-Extract[xonevel, {-1}] + Extract[xonevel, {2}]), ParallelTable[
(1 / 2) * (-Extract[xonevel, {i - 1}] + Extract[xonevel, {i - step}]), {i, 2, step - 1}],
(1 / 2) * (-Extract[xonevel, {step - 1}] + Extract[xonevel, {1}])}]; (*slope of xonevel*)
ListPlot[Thread[{phi, xoneacc}], PlotStyle → RGBColor[0, 0, 0],
PlotLabel → "x acceleration of point 1"]

yonepos = Flatten[ParallelTable[yone[Extract[phi, {i}]], {i, step}]];
ListPlot[Thread[{phi, yonepos}],
PlotStyle → RGBColor[0, 0, 0], PlotLabel → "y position of point 1"]
yonevel = Flatten[{(1 / 2) * (-Extract[yonepos, {-1}] + Extract[yonepos, {2}]), ParallelTable[
(1 / 2) * (-Extract[yonepos, {i - 1}] + Extract[yonepos, {i + 1}]), {i, 2, step - 1}],
(1 / 2) * (-Extract[yonepos, {step - 1}] + Extract[yonepos, {1}])}]; (*slope of yonepos*)
ListPlot[Thread[{phi, yonevel}], PlotStyle → RGBColor[0, 0, 0],
PlotLabel → "y velocity of point 1"]
```

```

yoneacc = Flatten[{(1/2) * (-Extract[yonevel, {-1}] + Extract[yonevel, {2}]), ParallelTable[
  (1/2) * (-Extract[yonevel, {i-1}] + Extract[yonevel, {i-step}]), {i, 2, step-1}],
  (1/2) * (-Extract[yonevel, {step-1}] + Extract[yonevel, {1}])]]; (*slope of yonevel*)
ListPlot[Thread[{phi, yoneacc}], PlotStyle -> RGBColor[0, 0, 0],
  PlotLabel -> "y acceleration of point 1"]
onevel = Sqrt[xonevel^2 + yonevel^2];
ListPlot[onevel, PlotStyle -> RGBColor[0, 0, 0],
  PlotLabel -> "magnitude of velocity of point 1"]
oneacc = Sqrt[xoneacc^2 + yoneacc^2];
ListPlot[oneacc, PlotStyle -> RGBColor[0, 0, 0],
  PlotLabel -> "magnitude of acceleration of point 1"]

(*velocity and acceleration of all points follows the same procedure as point 1*)

(*point 2*)
xtwopos = Flatten[ParallelTable[xtwo[Extract[z2o, {i}]], {i, step}]];
ListPlot[Thread[{phi, xtwopos}],
  PlotStyle -> RGBColor[0, 0, 0], PlotLabel -> "x position of point 2"]
xtwovel = Flatten[{(1/2) * (-Extract[xtwopos, {-1}] + Extract[xtwopos, {2}]),
  ParallelTable[(1/2) * (-Extract[xtwopos, {i-1}] + Extract[xtwopos, {i+1}]),
  {i, 2, step-1}], (1/2) * (-Extract[xtwopos, {step-1}] + Extract[xtwopos, {1}])]];
ListPlot[Thread[{phi, xtwovel}], PlotStyle -> RGBColor[0, 0, 0],
  PlotLabel -> "x velocity of point 2"]
xtwoacc = Flatten[{(1/2) * (-Extract[xtwovel, {-1}] + Extract[xtwovel, {2}]),
  ParallelTable[(1/2) * (-Extract[xtwovel, {i-1}] + Extract[xtwovel, {i-step}]),
  {i, 2, step-1}], (1/2) * (-Extract[xtwovel, {step-1}] + Extract[xtwovel, {1}])]];
ListPlot[Thread[{phi, xtwoacc}], PlotStyle -> RGBColor[0, 0, 0],
  PlotLabel -> "x acceleration of point 2"]

ytwopos = Flatten[ParallelTable[ytwo[Extract[z2o, {i}]], {i, step}]];
ListPlot[Thread[{phi, ytwopos}],
  PlotStyle -> RGBColor[0, 0, 0], PlotLabel -> "y position of point 2"]
ytwovel = Flatten[{(1/2) * (-Extract[ytwopos, {-1}] + Extract[ytwopos, {2}]),
  ParallelTable[(1/2) * (-Extract[ytwopos, {i-1}] + Extract[ytwopos, {i+1}]),
  {i, 2, step-1}], (1/2) * (-Extract[ytwopos, {step-1}] + Extract[ytwopos, {1}])]];
ListPlot[Thread[{phi, ytwovel}], PlotStyle -> RGBColor[0, 0, 0],
  PlotLabel -> "y velocity of point 2"]
ytwoacc = Flatten[{(1/2) * (-Extract[ytwovel, {-1}] + Extract[ytwovel, {2}]),
  ParallelTable[(1/2) * (-Extract[ytwovel, {i-1}] + Extract[ytwovel, {i-step}]),
  {i, 2, step-1}], (1/2) * (-Extract[ytwovel, {step-1}] + Extract[ytwovel, {1}])]];
ListPlot[Thread[{phi, ytwoacc}], PlotStyle -> RGBColor[0, 0, 0],
  PlotLabel -> "y acceleration of point 2"]
twovel = Sqrt[xtwovel^2 + ytwovel^2];
ListPlot[twovel, PlotStyle -> RGBColor[0, 0, 0],
  PlotLabel -> "magnitude of velocity of point 2"]
twoacc = Sqrt[xtwoacc^2 + ytwoacc^2];
ListPlot[twoacc, PlotStyle -> RGBColor[0, 0, 0],
  PlotLabel -> "magnitude of acceleration of point 2"]

```

```

(*point 4*)
xfourpos = Flatten[ParallelTable[xfour[Extract[x2o, {i}]], {i, step}]];
ListPlot[Thread[{phi, xfourpos}],
  PlotStyle → RGBColor[0, 0, 0], PlotLabel → "x position of point 4"]
xfourvel = Flatten[{{(1/2) * (-Extract[xfourpos, {-1}] + Extract[xfourpos, {2}]),
  ParallelTable[(1/2) * (-Extract[xfourpos, {i-1}] + Extract[xfourpos, {i+1}]),
    {i, 2, step-1}}, (1/2) * (-Extract[xfourpos, {step-1}] + Extract[xfourpos, {1}])}}];
ListPlot[Thread[{phi, xfourvel}], PlotStyle → RGBColor[0, 0, 0],
  PlotLabel → "x velocity of point 4"]
xfouracc = Flatten[{{(1/2) * (-Extract[xfourvel, {-1}] + Extract[xfourvel, {2}]),
  ParallelTable[(1/2) * (-Extract[xfourvel, {i-1}] + Extract[xfourvel, {i-step}]),
    {i, 2, step-1}}, (1/2) * (-Extract[xfourvel, {step-1}] + Extract[xfourvel, {1}])}}];
ListPlot[Thread[{phi, xfouracc}], PlotStyle → RGBColor[0, 0, 0],
  PlotLabel → "x acceleration of point 4"]

yfourpos = Flatten[ParallelTable[yfour[Extract[x2o, {i}]], {i, step}]];
ListPlot[Thread[{phi, yfourpos}],
  PlotStyle → RGBColor[0, 0, 0], PlotLabel → "y position of point 4"]
yfourvel = Flatten[{{(1/2) * (-Extract[yfourpos, {-1}] + Extract[yfourpos, {2}]),
  ParallelTable[(1/2) * (-Extract[yfourpos, {i-1}] + Extract[yfourpos, {i+1}]),
    {i, 2, step-1}}, (1/2) * (-Extract[yfourpos, {step-1}] + Extract[yfourpos, {1}])}}];
ListPlot[Thread[{phi, yfourvel}], PlotStyle → RGBColor[0, 0, 0],
  PlotLabel → "y velocity of point 4"]
yfouracc = Flatten[{{(1/2) * (-Extract[yfourvel, {-1}] + Extract[yfourvel, {2}]),
  ParallelTable[(1/2) * (-Extract[yfourvel, {i-1}] + Extract[yfourvel, {i-step}]),
    {i, 2, step-1}}, (1/2) * (-Extract[yfourvel, {step-1}] + Extract[yfourvel, {1}])}}];
ListPlot[Thread[{phi, yfouracc}], PlotStyle → RGBColor[0, 0, 0],
  PlotLabel → "y acceleration of point 4"]
fourvel = Sqrt[xfourvel^2 + yfourvel^2];
ListPlot[fourvel, PlotStyle → RGBColor[0, 0, 0],
  PlotLabel → "magnitude of velocity of point 4"]
fouracc = Sqrt[xfouracc^2 + yfouracc^2];
ListPlot[fouracc, PlotStyle → RGBColor[0, 0, 0],
  PlotLabel → "magnitude of acceleration of point 4"]

(*point 5*)
xfivepos = Flatten[ParallelTable[xfive[Extract[y2o, {i}]], {i, step}]];
ListPlot[Thread[{phi, xfivepos}],
  PlotStyle → RGBColor[0, 0, 0], PlotLabel → "x position of point 5"]
xfivevel = Flatten[{{(1/2) * (-Extract[xfivepos, {-1}] + Extract[xfivepos, {2}]),
  ParallelTable[(1/2) * (-Extract[xfivepos, {i-1}] + Extract[xfivepos, {i+1}]),
    {i, 2, step-1}}, (1/2) * (-Extract[xfivepos, {step-1}] + Extract[xfivepos, {1}])}}];
ListPlot[Thread[{phi, xfivevel}], PlotStyle → RGBColor[0, 0, 0],
  PlotLabel → "x velocity of point 5"]
xfiveacc = Flatten[{{(1/2) * (-Extract[xfivevel, {-1}] + Extract[xfivevel, {2}]),
  ParallelTable[(1/2) * (-Extract[xfivevel, {i-1}] + Extract[xfivevel, {i-step}]),
    {i, 2, step-1}}, (1/2) * (-Extract[xfivevel, {step-1}] + Extract[xfivevel, {1}])}}];
ListPlot[Thread[{phi, xfiveacc}], PlotStyle → RGBColor[0, 0, 0],
  PlotLabel → "x acceleration of point 5"]

```

```

yfivepos = Flatten[ParallelTable[yfive[Extract[y2o, {i}]], {i, step}]];
ListPlot[Thread[{phi, yfivepos}],
  PlotStyle → RGBColor[0, 0, 0], PlotLabel → "y position of point 5"]
yfivevel = Flatten[{(1/2) * (-Extract[yfivepos, {-1}] + Extract[yfivepos, {2}]),
  ParallelTable[(1/2) * (-Extract[yfivepos, {i-1}] + Extract[yfivepos, {i+1}]),
    {i, 2, step-1}], (1/2) * (-Extract[yfivepos, {step-1}] + Extract[yfivepos, {1}])}]];
ListPlot[Thread[{phi, yfivevel}], PlotStyle → RGBColor[0, 0, 0],
  PlotLabel → "y velocity of point 5"]
yfiveacc = Flatten[{(1/2) * (-Extract[yfivevel, {-1}] + Extract[yfivevel, {2}]),
  ParallelTable[(1/2) * (-Extract[yfivevel, {i-1}] + Extract[yfivevel, {i-step}]),
    {i, 2, step-1}], (1/2) * (-Extract[yfivevel, {step-1}] + Extract[yfivevel, {1}])}]];
ListPlot[Thread[{phi, yfiveacc}], PlotStyle → RGBColor[0, 0, 0],
  PlotLabel → "y acceleration of point 5", PlotRange → {{0, 2 * Pi}, {1.2, -1}}]
fivevel = Sqrt[xfivevel^2 + yfivevel^2];
ListPlot[fivevel, PlotStyle → RGBColor[0, 0, 0],
  PlotLabel → "magnitude of velocity of point 5"]
fiveacc = Sqrt[xfiveacc^2 + yfiveacc^2];
ListPlot[fiveacc, PlotStyle → RGBColor[0, 0, 0],
  PlotLabel → "magnitude of acceleration of point 5"]

(*point 6*)
xsixpos =
  Flatten[ParallelTable[xfour[Extract[x2o, {i}]] + f * Cos[Extract[w2o, {i}]], {i, step}]];
ListPlot[Thread[{phi, xsixpos}], PlotStyle → RGBColor[0, 0, 0],
  PlotLabel → "x position of point 6"]
xsixvel = Flatten[{(1/2) * (-Extract[xsixpos, {-1}] + Extract[xsixpos, {2}]),
  ParallelTable[(1/2) * (-Extract[xsixpos, {i-1}] + Extract[xsixpos, {i+1}]),
    {i, 2, step-1}], (1/2) * (-Extract[xsixpos, {step-1}] + Extract[xsixpos, {1}])}]];
ListPlot[Thread[{phi, xsixvel}], PlotStyle → RGBColor[0, 0, 0],
  PlotLabel → "x velocity of point 6"]
xsixacc = Flatten[{(1/2) * (-Extract[xsixvel, {-1}] + Extract[xsixvel, {2}]),
  ParallelTable[(1/2) * (-Extract[xsixvel, {i-1}] + Extract[xsixvel, {i-step}]),
    {i, 2, step-1}], (1/2) * (-Extract[xsixvel, {step-1}] + Extract[xsixvel, {1}])}]];
ListPlot[Thread[{phi, xsixacc}], PlotStyle → RGBColor[0, 0, 0],
  PlotLabel → "x acceleration of point 6"]

ysixpos =
  Flatten[ParallelTable[yfour[Extract[x2o, {i}]] + f * Sin[Extract[w2o, {i}]], {i, step}]];
ListPlot[Thread[{phi, ysixpos}], PlotStyle → RGBColor[0, 0, 0],
  PlotLabel → "y position of point 6"]
ysixvel = Flatten[{(1/2) * (-Extract[ysixpos, {-1}] + Extract[ysixpos, {2}]),
  ParallelTable[(1/2) * (-Extract[ysixpos, {i-1}] + Extract[ysixpos, {i+1}]),
    {i, 2, step-1}], (1/2) * (-Extract[ysixpos, {step-1}] + Extract[ysixpos, {1}])}]];
ListPlot[Thread[{phi, ysixvel}], PlotStyle → RGBColor[0, 0, 0],
  PlotLabel → "y velocity of point 6"]
ysixacc = Flatten[{(1/2) * (-Extract[ysixvel, {-1}] + Extract[ysixvel, {2}]),
  ParallelTable[(1/2) * (-Extract[ysixvel, {i-1}] + Extract[ysixvel, {i-step}]),
    {i, 2, step-1}], (1/2) * (-Extract[ysixvel, {step-1}] + Extract[ysixvel, {1}])}]];
ListPlot[Thread[{phi, ysixacc}], PlotStyle → RGBColor[0, 0, 0],
  PlotLabel → "y acceleration of point 6"]

```

```

sixvel = Sqrt[xsixvel^2 + ysixvel^2];
ListPlot[sixvel, PlotStyle → RGBColor[0, 0, 0],
  PlotLabel → "magnitude of velocity of point 6"]
sixacc = Sqrt[xsixacc^2 + ysixacc^2];
ListPlot[sixacc, PlotStyle → RGBColor[0, 0, 0],
  PlotLabel → "magnitude of acceleration of point 6"]

(*point 7*)
xsevenpos = x7o;
ListPlot[Thread[{phi, xsevenpos}],
  PlotStyle → RGBColor[0, 0, 0], PlotLabel → "x position of point 7"]
xsevenvel = Flatten[{(1/2) * (-Extract[xsevenpos, {-1}] + Extract[xsevenpos, {2}]),
  ParallelTable[(1/2) * (-Extract[xsevenpos, {i-1}] + Extract[xsevenpos, {i+1}]),
    {i, 2, step-1}], (1/2) * (-Extract[xsevenpos, {step-1}] + Extract[xsevenpos, {1}])}];
ListPlot[Thread[{phi, xsevenvel}], PlotStyle → RGBColor[0, 0, 0],
  PlotLabel → "x velocity of point 7"]
xsevenacc = Flatten[{(1/2) * (-Extract[xsevenvel, {-1}] + Extract[xsevenvel, {2}]),
  ParallelTable[(1/2) * (-Extract[xsevenvel, {i-1}] + Extract[xsevenvel, {i-step}]),
    {i, 2, step-1}], (1/2) * (-Extract[xsevenvel, {step-1}] + Extract[xsevenvel, {1}])}];
ListPlot[Thread[{phi, xsevenacc}], PlotStyle → RGBColor[0, 0, 0],
  PlotLabel → "x acceleration of point 7"]

ysevenpos = y7o;
ListPlot[Thread[{phi, ysevenpos}],
  PlotStyle → RGBColor[0, 0, 0], PlotLabel → "y position of point 7"]
ysevenvel = Flatten[{(1/2) * (-Extract[ysevenpos, {-1}] + Extract[ysevenpos, {2}]),
  ParallelTable[(1/2) * (-Extract[ysevenpos, {i-1}] + Extract[ysevenpos, {i+1}]),
    {i, 2, step-1}], (1/2) * (-Extract[ysevenpos, {step-1}] + Extract[ysevenpos, {1}])}];
ListPlot[Thread[{phi, ysevenvel}], PlotStyle → RGBColor[0, 0, 0],
  PlotLabel → "y velocity of point 7"]
ysevenacc = Flatten[{(1/2) * (-Extract[ysevenvel, {-1}] + Extract[ysevenvel, {2}]),
  ParallelTable[(1/2) * (-Extract[ysevenvel, {i-1}] + Extract[ysevenvel, {i-step}]),
    {i, 2, step-1}], (1/2) * (-Extract[ysevenvel, {step-1}] + Extract[ysevenvel, {1}])}];
ListPlot[Thread[{phi, ysevenacc}], PlotStyle → RGBColor[0, 0, 0],
  PlotLabel → "y acceleration of point 7"]
sevenvel = Sqrt[xsevenvel^2 + ysevenvel^2];
ListPlot[Thread[{phi, sevenvel}], PlotStyle → RGBColor[0, 0, 0],
  PlotLabel → "magnitude of velocity of point 7"]
sevenacc = Sqrt[xsevenacc^2 + ysevenacc^2];
ListPlot[Thread[{phi, sevenacc}], PlotStyle → RGBColor[0, 0, 0],
  PlotLabel → "magnitude of acceleration of point 7"]

```

```
(*POSITION OF CRANK PAIR*)
```



```

(*reverse the order of the elements in each array to get pair to trace each
 path backwards, all x coordinates of pair have opposite sign as original leg*)
xonepair = -Reverse[xonepos];
xtwopair = -Reverse[xtwopos];
xthreepair = a;
xfourpair = -Reverse[xfourpos];
xfivepair = -Reverse[xfivepos];
xsixpair = -Reverse[xsixpos];
xsevenpair = -Reverse[xsevenpos];
yonepair = Reverse[yonepos];
ytwopair = Reverse[ytwopos];
ythreepair = -1;
yfourpair = Reverse[yfourpos];
yfivepair = Reverse[yfivepos];
ysixpair = Reverse[ysixpos];
ysevenpair = Reverse[ysevenpos];
positionoffootpair =
  ListPlot[Thread[{xsevenpair, ysevenpair}], PlotStyle → RGBColor[0, 0, 0]];

legpair = ListLinePlot[
  {{Extract[xonepair, {example - step / 2 - 1}], Extract[yonepair, {example - step / 2 - 1}]},
   {Extract[xtwopair, {example - step / 2 - 1}], Extract[ytwopair, {example - step / 2 - 1}]},
   {xthreepair, ythreepair},
   {Extract[xfivepair, {example - step / 2 - 1}], Extract[yfivepair, {example - step / 2 - 1}]},
   {Extract[xonepair, {example - step / 2 - 1}], Extract[yonepair, {example - step / 2 - 1}]},
   {{Extract[xtwopair, {example - step / 2 - 1}], Extract[ytwopair, {example - step / 2 - 1}]},
    {Extract[xfourpair, {example - step / 2 - 1}], Extract[yfourpair, {example - step / 2 - 1}]},
    {xthreepair, ythreepair}},
   {{Extract[xfourpair, {example - step / 2 - 1}], Extract[yfourpair, {example - step / 2 - 1}]},
    {Extract[xsixpair, {example - step / 2 - 1}], Extract[ysixpair, {example - step / 2 - 1}]},
    {Extract[xfivepair, {example - step / 2 - 1}], Extract[yfivepair, {example - step / 2 - 1}]},
    {Extract[xsevenpair, {example - step / 2 - 1}], Extract[ysevenpair, {example - step / 2 - 1}]},
    {Extract[xsixpair, {example - step / 2 - 1}], Extract[ysixpair, {example - step / 2 - 1}]}}},
  PlotStyle → RGBColor[0, 0, 0]]; (*plot a diagram
of the linkage's pair for a given
time
step
specified
by
"example,"
also
introduce
a
phase
shift
of
1/2*)

```

```

leg = ListLinePlot[{{xone[2 * (example - 1) * Pi / step], yone[2 * (example - 1) * Pi / step]},
  {xtwo[Extract[z2o, {example}]], ytwo[Extract[z2o, {example}]]}, {xthree, ythree},
  {xfive[Extract[y2o, {example}]], yfive[Extract[y2o, {example}]]},
  {xone[2 * (example - 1) * Pi / step], yone[2 * (example - 1) * Pi / step]}},
  {{xtwo[Extract[z2o, {example}]], ytwo[Extract[z2o, {example}]]},
  {xfour[Extract[x2o, {example}]], yfour[Extract[x2o, {example}]]}, {xthree, ythree}},
  {{xtwo[Extract[z2o, {example}]], ytwo[Extract[z2o, {example}]]},
  {xfour[Extract[x2o, {example}]], yfour[Extract[x2o, {example}]]}, {xthree, ythree}},
  {{xfour[Extract[x2o, {example}]], yfour[Extract[x2o, {example}]]},
  {xfour[Extract[x2o, {example}]] + f * Cos[Extract[w2o, {example}]],
   yfour[Extract[x2o, {example}]] + f * Sin[Extract[w2o, {example}]]},
  {xfive[Extract[y2o, {example}]], yfive[Extract[y2o, {example}]]},
  {Extract[x7o, {example}], Extract[y7o, {example}]},
  {xfour[Extract[x2o, {example}]] + f * Cos[Extract[w2o, {example}]],
   yfour[Extract[x2o, {example}]] + f * Sin[Extract[w2o, {example}]]}}},
  PlotStyle → RGBColor[0, 0, 0]]; (*plot a diagram
of the linkage for a given time step
specified
by
"example"*)

```

```

Show[{crank, positionoffoot, leg, positionoffootpair, legpair},
  PlotRange → {{-120, 120}, {-100, 40}}, PlotLabel → "12 of 12"
] (*plot the position of the crank and both pairs of feet for all time steps
with a diagram of the linkage at the time step specified by "example"*)

```

(*SOLVING AND PLOTTING CENTER OF MASS*)

```

(*define vecotors describing x and y positions of crank (point 1)*)
xxone = ParallelTable[{xone[2 * (i - 1) * Pi / step]}, {i, step}];
yyone = ParallelTable[{yone[2 * (i - 1) * Pi / step]}, {i, step}];

(*define position of crank axis (point 0)*)
xzero = 0;
yzero = 0;

(*note: all of these calculations assume uniform density throughout the linkage, thus,
the center of mass of each part of the linkage is located at the center of each link*)

(*halfway between points 0 and 1*)
cmxzeroone = Flatten[ParallelTable[{xzero + m / 2 * Cos[2 * (i - 1) * Pi / step]}, {i, step}]];
cmzeroone = Flatten[ParallelTable[{yzero + m / 2 * Sin[2 * (i - 1) * Pi / step]}, {i, step}]];
cmzeroone =

```

```

ListPlot[Thread[{cmxzeroone, cmyzeroone}], PlotLabel → "crank cm", AspectRatio → Automatic,
PlotRange → {{-120, 30}, {-100, 40}}, PlotStyle → {RGBColor[0, 0, 1], PointSize[0.007]};
(*plot the position of cm for entire locomotive cycle*)
Show[ListLinePlot[ParallelTable[
  {{xone[2 * (i - 1) * Pi / step], yone[2 * (i - 1) * Pi / step]}, {xzero, yzero}}, {i, step}},
  AspectRatio → Automatic, PlotRange → {{-120, 30}, {-100, 40}},
  PlotStyle → RGBColor[0, 0, 0]], cmzeroone, PlotLabel → "CM of crank"]
(*superimpose the position of the linkage joining points 0 and
1 for entire locomotive cycle on the previous plot*)

(*halfway between points 2 and 3*)
cmxtwothree[thetaone_] := xthree + b / 2 * Cos[thetaone];
cmytwothree[thetaone_] := ythree + b / 2 * Sin[thetaone];
cmthreetwo = ListPlot[Thread[{cmxtwothree[z2o], cmytwothree[z2o]}],
  PlotLabel → position_twocm, AspectRatio → Automatic,
  PlotRange → {{-120, 30}, {-100, 40}}, PlotStyle → {RGBColor[0, 0, 1], PointSize[0.007]};
(*plot the position of cm for entire locomotive cycle*)
Show[ListLinePlot[ParallelTable[
  {{xtwo[Extract[z2o, {i}]], ytwo[Extract[z2o, {i}]]}, {xthree, ythree}}, {i, step}},
  AspectRatio → Automatic, PlotRange → {{-120, 30}, {-100, 40}}, PlotStyle → RGBColor[0, 0, 0]],
  cmthreetwo, PlotLabel → "CM of bar between points 2 and 3"]
(*superimpose the position of the linkage joining points 2
and 3 for entire locomotive cycle on the previous plot*)

(*halfway between points 5 and 3*)
cmxfivethree[thetatwo_] := xthree + c / 2 * Cos[thetatwo];
cmyfivethree[thetatwo_] := ythree + c / 2 * Sin[thetatwo];
cmthreefive = ListPlot[Thread[{cmxfivethree[y2o], cmyfivethree[y2o]}],
  PlotLabel → position_fivecm, AspectRatio → Automatic,
  PlotRange → {{-120, 30}, {-100, 40}}, PlotStyle → {RGBColor[0, 0, 1], PointSize[0.007]};
(*plot the position of cm for entire locomotive cycle*)
Show[ListLinePlot[ParallelTable[
  {{xthree, ythree}, {xfive[Extract[y2o, {i}]], yfive[Extract[y2o, {i}]]}}, {i, step}},
  AspectRatio → Automatic, PlotRange → {{-120, 30}, {-100, 40}}, PlotStyle → RGBColor[0, 0, 0]],
  cmthreefive, PlotLabel → "CM of bar between points 5 and 3"]
(*superimpose the position of the linkage joining points 5
and 3 for entire locomotive cycle on the previous plot*)

(*halfway between points 4 and 3*)
cmxfourthree[thetathree_] := xthree + d / 2 * Cos[thetathree];
cmyfourthree[thetathree_] := ythree + d / 2 * Sin[thetathree];
cmthreefour = ListPlot[Thread[{cmxfourthree[x2o], cmyfourthree[x2o]}],
  PlotLabel → position_fourcm, AspectRatio → Automatic,
  PlotRange → {{-120, 30}, {-100, 40}}, PlotStyle → {RGBColor[0, 0, 1], PointSize[0.007]};
(*plot the position of cm for entire locomotive cycle*)
Show[ListLinePlot[ParallelTable[
  {{xthree, ythree}, {xfour[Extract[x2o, {i}]], yfour[Extract[x2o, {i}]]}}, {i, step}},
  AspectRatio → Automatic, PlotRange → {{-120, 30}, {-100, 40}}, PlotStyle → RGBColor[0, 0, 0]],

```

```

cmthreefour, PlotLabel → "CM of bar between points 4 and 3"]
(*superimpose the position of the linkage joining points 4
and 3 for entire locomotive cycle on the previous plot*)

(*halfway between points 1 and 2*)
cmxonetwo = Flatten[
  ParallelTable[(1/2) Extract[xxone, {i}] + (1/2) xtwo[Extract[z2o, {i}]], {i, step}]];
cmyonetwo = Flatten[ParallelTable[(1/2) Extract[yyone, {i}] +
  (1/2) ytwo[Extract[z2o, {i}]], {i, step}]];
cmonetwo = ListPlot[Thread[{cmxonetwo, cmyonetwo}], AspectRatio → Automatic,
  PlotRange → {{-120, 30}, {-100, 40}}, PlotStyle → {RGBColor[0, 0, 1], PointSize[0.007]}];
(*plot the position of cm for entire locomotive cycle*)
Show[ListLinePlot[ParallelTable[{{xone[2 * (i - 1) * Pi / step], yone[2 * (i - 1) * Pi / step]},
  {xtwo[Extract[z2o, {i}]], ytwo[Extract[z2o, {i}]]}}, {i, step}], AspectRatio → Automatic,
  PlotRange → {{-120, 30}, {-100, 40}}, PlotStyle → RGBColor[0, 0, 0]],
  cmonetwo, PlotLabel → "CM of bar between points 1 and 2"]
(*superimpose the position of the linkage joining points 1
and 2 for entire locomotive cycle on the previous plot*)

(*halfway between points 1 and 5*)
cmxonefive = Flatten[
  ParallelTable[(1/2) Extract[xxone, {i}] + (1/2) xfive[Extract[y2o, {i}]], {i, step}]];
cmyonefive = Flatten[ParallelTable[(1/2) Extract[yyone, {i}] +
  (1/2) yfive[Extract[y2o, {i}]], {i, step}]];
cmonefive = ListPlot[Thread[{cmxonefive, cmyonefive}], AspectRatio → Automatic,
  PlotRange → {{-120, 30}, {-100, 40}}, PlotStyle → {RGBColor[0, 0, 1], PointSize[0.007]}];
(*plot the position of cm for entire locomotive cycle*)
Show[ListLinePlot[ParallelTable[{{xfive[Extract[y2o, {i}]], yfive[Extract[y2o, {i}]]},
  {xone[2 * (i - 1) * Pi / step], yone[2 * (i - 1) * Pi / step]}}, {i, step}],
  AspectRatio → Automatic, PlotRange → {{-120, 30}, {-100, 40}}, PlotStyle → RGBColor[0, 0, 0]],
  cmonefive, PlotLabel → "CM of bar between points 1 and 5"]
(*superimpose the position of the linkage joining points 1
and 5 for entire locomotive cycle on the previous plot*)

(*halfway between points 2 and 4*)
cmxtwofour = Flatten[
  ParallelTable[(1/2) xtwo[Extract[z2o, {i}]] + (1/2) xfour[Extract[x2o, {i}]], {i, step}]];
cmytwofour = Flatten[ParallelTable[(1/2) ytwo[Extract[z2o, {i}]] +
  (1/2) yfour[Extract[x2o, {i}]], {i, step}]];
cmtwofour = ListPlot[Thread[{cmxtwofour, cmytwofour}], AspectRatio → Automatic,
  PlotRange → {{-120, 30}, {-100, 40}}, PlotStyle → {RGBColor[0, 0, 1], PointSize[0.007]}];
(*plot the position of cm for entire locomotive cycle*)
Show[ListLinePlot[ParallelTable[{{xtwo[Extract[z2o, {i}]], ytwo[Extract[z2o, {i}]]},
  {xfour[Extract[x2o, {i}]], yfour[Extract[x2o, {i}]]}}, {i, step}],
  AspectRatio → Automatic, PlotRange → {{-120, 30}, {-100, 40}}, PlotStyle → RGBColor[0, 0, 0]],
  cmtwofour, PlotLabel → "CM of bar between points 2 and 4"]
(*superimpose the position of the linkage joining points 2
and 4 for entire locomotive cycle on the previous plot*)

```

```

(*halfway between points 4 and 6*)
cmxfoursix =
  Flatten[ParallelTable[xfour[Extract[x2o, {i}]] + f / 2 * Cos[Extract[w2o, {i}]], {i, step}]];
cmyfoursix = Flatten[ParallelTable[
  yfour[Extract[x2o, {i}]] + f / 2 * Sin[Extract[w2o, {i}]], {i, step}]];
cmfoursix = ListPlot[Thread[{cmxfoursix, cmyfoursix}], AspectRatio → Automatic,
  PlotRange → {{-120, 30}, {-100, 40}}, PlotStyle → {RGBColor[0, 0, 1], PointSize[0.007]};
(*plot the position of cm for entire locomotive cycle*)
Show[ListLinePlot[ParallelTable[{xfour[Extract[x2o, {i}]], yfour[Extract[x2o, {i}]],
  {xfour[Extract[x2o, {i}]] + f * Cos[Extract[w2o, {i}]],
  yfour[Extract[x2o, {i}]] + f * Sin[Extract[w2o, {i}]]}], {i, step}],
  AspectRatio → Automatic, PlotRange → {{-120, 30}, {-100, 40}},
  PlotStyle → RGBColor[0, 0, 0], cmfoursix,
  PlotLabel → "CM of bar between points 4 and 6"]
(*superimpose the position of the linkage joining points 4
and 6 for entire locomotive cycle on the previous plot*)

```

```

(*halfway between points 5 and 6*)
cmxfivesix =
  Flatten[ParallelTable[(1 / 2) (xfour[Extract[x2o, {i}]] + f * Cos[Extract[w2o, {i}]] +
  (1 / 2) xfive[Extract[y2o, i]], {i, step}]];
cmyfivesix = Flatten[ParallelTable[(1 / 2) (yfour[Extract[x2o, {i}]] +
  f * Sin[Extract[w2o, {i}]] + (1 / 2) yfive[Extract[y2o, i]], {i, step}]];
cmfivesix = ListPlot[Thread[{cmxfivesix, cmyfivesix}], AspectRatio → Automatic,
  PlotRange → {{-120, 30}, {-100, 40}}, PlotStyle → {RGBColor[0, 0, 1], PointSize[0.007]};
(*plot the position of cm for entire locomotive cycle*)
Show[ListLinePlot[ParallelTable[{xfour[Extract[x2o, {i}]] + f * Cos[Extract[w2o, {i}]],
  yfour[Extract[x2o, {i}]] + f * Sin[Extract[w2o, {i}]]},
  {xfive[Extract[y2o, {i}]], yfive[Extract[y2o, {i}]]}], {i, step}],
  AspectRatio → Automatic, PlotRange → {{-120, 30}, {-100, 40}},
  PlotStyle → RGBColor[0, 0, 0], cmfivesix,
  PlotLabel → "CM of bar between points 5 and 6"]
(*superimpose the position of the linkage joining points 5
and 6 for entire locomotive cycle on the previous plot*)

```

```

(*halfway between points 7 and 6*)
cmxsevensix =
  Flatten[ParallelTable[(1 / 2) (xfour[Extract[x2o, {i}]] + f * Cos[Extract[w2o, {i}]] +
  (1 / 2) Extract[x7o, i], {i, step}]];
cmysevensix = Flatten[ParallelTable[(1 / 2) (yfour[Extract[x2o, {i}]] +
  f * Sin[Extract[w2o, {i}]] + (1 / 2) Extract[y7o, i], {i, step}]];
cmsevensix = ListPlot[Thread[{cmxsevensix, cmysevensix}], AspectRatio → Automatic,
  PlotRange → {{-120, 30}, {-100, 40}}, PlotStyle → {RGBColor[0, 0, 1], PointSize[0.007]};
(*plot the position of cm for entire locomotive cycle*)
Show[ListLinePlot[ParallelTable[{xfour[Extract[x2o, {i}]] + f * Cos[Extract[w2o, {i}]],
  yfour[Extract[x2o, {i}]] + f * Sin[Extract[w2o, {i}]]},
  {Extract[x7o, {i}], Extract[y7o, {i}]}], {i, step}], AspectRatio → Automatic,

```

```

PlotRange → {{-120, 30}, {-100, 40}}, PlotStyle → RGBColor[0, 0, 0],
cmsevenix, PlotLabel → "CM of bar between points 7 and 6"
(*superimpose the position of the linkage joining points 7
and 6 for entire locomotive cycle on the previous plot*)

(*halfway between points 7 and 5*)
cmsevenfive = Flatten[
  ParallelTable[(1/2) Extract[x7o, {i}] + (1/2) xfive[Extract[y2o, {i}]], {i, step}]];
cmsevenfive = Flatten[ParallelTable[(1/2) Extract[y7o, {i}] +
  (1/2) yfive[Extract[y2o, {i}]], {i, step}]];
cmsevenfive = ListPlot[Thread[{cmsevenfive, cmsevenfive}], AspectRatio → Automatic,
  PlotRange → {{-120, 30}, {-100, 40}}, PlotStyle → {RGBColor[0, 0, 1], PointSize[0.007]}];
(*plot the position of cm for entire locomotive cycle*)
Show[ListLinePlot[ParallelTable[{xfive[Extract[y2o, {i}]], yfive[Extract[y2o, {i}]]},
  {Extract[x7o, {i}], Extract[y7o, {i}]], {i, step}], AspectRatio → Automatic,
  PlotRange → {{-120, 30}, {-100, 40}}, PlotStyle → RGBColor[0, 0, 0]],
  cmsevenfive, PlotLabel → "CM of bar between points 7 and 5"
(*superimpose the position of the linkage joining points 7
and 6 for entire locomotive cycle on the previous plot*)

(*the center of mass of the entire linkage is the superposition of each
contributing part weighted by its mass. Since mass is proportional to length,
I have multiplied by length instead of mass*)
cmx = Flatten[ParallelTable[
  {(m * Extract[cmxzeroone, {i}] + r * Extract[cmxonetwo, {i}] + k * Extract[cmxonefive, {i}] +
  e * Extract[cmxtwofour, {i}] + f * Extract[cmxfoursix, {i}] +
  g * Extract[cmxfivesix, {i}] + h * Extract[cmxsevensix, {i}] +
  o * Extract[cmxsevenfive, {i}] + b * cmxtwothree[Extract[z2o, {i}]] +
  c * cmxfivethree[Extract[y2o, {i}]] + d * cmxfourthree[Extract[x2o, {i}]]} /
  (m + r + k + e + f + g + h + o + b + c + d)}, {i, step}]];
cmy = Flatten[ParallelTable[{(m * Extract[cmyzeroone, {i}] + r * Extract[cmyonetwo, {i}] +
  k * Extract[cmyonefive, {i}] + e * Extract[cmytwofour, {i}] +
  f * Extract[cmyfoursix, {i}] + g * Extract[cmyfivesix, {i}] +
  h * Extract[cmysevensix, {i}] + o * Extract[cmysevenfive, {i}] +
  b * cmytwothree[Extract[z2o, {i}]] + c * cmyfivethree[Extract[y2o, {i}]] +
  d * cmyfourthree[Extract[x2o, {i}]]} / (m + r + k + e + f + g + h + o + b + c + d)}, {i, step}]];
cm = ListPlot[Thread[{cmx, cmy}], PlotLabel → "CM", AspectRatio → Automatic,
  PlotRange → {{-120, 30}, {-100, 40}}, PlotStyle → {RGBColor[0, 0, 1], PointSize[0.007]}];
(*plot position of total center of mass for entire locomotive cycle*)

Show[ListLinePlot[Flatten[
  ParallelTable[{{xzero, yzero}, {xone[2 * (i - 1) * Pi / step], yone[2 * (i - 1) * Pi / step]},
  {xtwo[Extract[z2o, {i}]], ytwo[Extract[z2o, {i}]]}, {xthree, ythree},
  {xfive[Extract[y2o, {i}]], yfive[Extract[y2o, {i}]]}, {xone[2 * (i - 1) * Pi / step],
  yone[2 * (i - 1) * Pi / step]}, {{xtwo[Extract[z2o, {i}]], ytwo[Extract[z2o, {i}]]},
  {xfour[Extract[x2o, {i}]], yfour[Extract[x2o, {i}]]}, {xthree, ythree}},
  {{xtwo[Extract[z2o, {i}]], ytwo[Extract[z2o, {i}]]}},

```

```

    {xfour[Extract[x2o, {i}]], yfour[Extract[x2o, {i}]]}, {xthree, ythree}},
    {{xfour[Extract[x2o, {i}]], yfour[Extract[x2o, {i}]]}, {xfour[Extract[x2o, {i}]] +
      f * Cos[Extract[w2o, {i}]], yfour[Extract[x2o, {i}]] + f * Sin[Extract[w2o, {i}]]},
    {xfive[Extract[y2o, {i}]], yfive[Extract[y2o, {i}]]}, {Extract[x7o, {i}],
      Extract[y7o, {i}]}, {xfour[Extract[x2o, {i}]] + f * Cos[Extract[w2o, {i}]],
      yfour[Extract[x2o, {i}]] + f * Sin[Extract[w2o, {i}]]}}, {i, 1, step, step / 24}], 1],
    PlotStyle → RGBColor[0, 0, 0], cmzeroone, cmthreetwo,
    cmthreefive, cmthreefour,
    cmonetwo,
    cmonefive,
    cmtwofour,
    cmfoursix,
    cmfivesix,
    cmsevensix,
    cmsevenfive,
    AspectRatio → Automatic,
    PlotRange → {{-120, 30}, {-100, 40}},
    PlotLabel →
    "Linkage with CM of each link shown for entire locomotive cycle"]
(*superimpose plots of contributing
center
of
masses
over
diagram
of
linkage
for
entire
locomotive
cycle*)

```

```

Show[ListLinePlot[Flatten[
  ParallelTable[{{{xzero, yzero}, {xone[2 * (i - 1) * Pi / step], yone[2 * (i - 1) * Pi / step]},
    {xtwo[Extract[z2o, {i}]], ytwo[Extract[z2o, {i}]]}, {xthree, ythree},
    {xfive[Extract[y2o, {i}]], yfive[Extract[y2o, {i}]]}, {xone[2 * (i - 1) * Pi / step],
      yone[2 * (i - 1) * Pi / step]}}, {{xtwo[Extract[z2o, {i}]], ytwo[Extract[z2o, {i}]]},
    {xfour[Extract[x2o, {i}]], yfour[Extract[x2o, {i}]]}, {xthree, ythree}},
    {{xtwo[Extract[z2o, {i}]], ytwo[Extract[z2o, {i}]]},
    {xfour[Extract[x2o, {i}]], yfour[Extract[x2o, {i}]]}, {xthree, ythree}},
    {{xfour[Extract[x2o, {i}]], yfour[Extract[x2o, {i}]]}, {xfour[Extract[x2o, {i}]] +
      f * Cos[Extract[w2o, {i}]], yfour[Extract[x2o, {i}]] + f * Sin[Extract[w2o, {i}]]},
    {xfive[Extract[y2o, {i}]], yfive[Extract[y2o, {i}]]}, {Extract[x7o, {i}],
      Extract[y7o, {i}]}, {xfour[Extract[x2o, {i}]] + f * Cos[Extract[w2o, {i}]],
      yfour[Extract[x2o, {i}]] + f * Sin[Extract[w2o, {i}]]}}, {i, 1, step, step / 24}], 1],
    PlotStyle → RGBColor[0, 0, 0], AspectRatio → Automatic,
    PlotRange → {{-120, 30}, {-100, 40}}, cm,
    PlotLabel → "Total CM shown with linkage for entire locomotive cycle"]
(*superimpose

```

```

plot
of
total
center
of
mass
over
plot
of
linkage
over
entire
locomotive
cycle*)

ListPlot[cmx, PlotStyle → RGBColor[0, 0, 0],
  PlotLabel → "x position of CM in one locomotive cycle"
  (*plot x position of total center of mass*)
ListPlot[cmx, PlotStyle → RGBColor[0, 0, 0],
  PlotLabel → "y position of CM in one locomotive cycle"
  (*plot y position of total center of mass*)

(*x and y velocity and acceleration of total cm*)
cmxvel = Flatten[{(1/2) * (-Extract[cmx, {-1}] + Extract[cmx, {2}]),
  ParallelTable[(1/2) * (-Extract[cmx, {i-1}] + Extract[cmx, {i+1}]), {i, 2, step-1}],
  (1/2) * (-Extract[cmx, {step-1}] + Extract[cmx, {1}])}];
ListPlot[cmxvel, PlotStyle → RGBColor[0, 0, 0], PlotLabel → "x velocity of total CM"
cmxacc = Flatten[{(1/2) * (-Extract[cmxvel, {-1}] + Extract[cmxvel, {2}]),
  ParallelTable[(1/2) * (-Extract[cmxvel, {i-1}] + Extract[cmxvel, {i-step}]),
  {i, 2, step-1}], (1/2) * (-Extract[cmxvel, {step-1}] + Extract[cmxvel, {1}])}];
ListPlot[cmxacc, PlotStyle → RGBColor[0, 0, 0], PlotLabel → "x acceleration of total CM"
cmxvel = Flatten[{(1/2) * (-Extract[cmx, {-1}] + Extract[cmx, {2}]),
  ParallelTable[(1/2) * (-Extract[cmx, {i-1}] + Extract[cmx, {i+1}]), {i, 2, step-1}],
  (1/2) * (-Extract[cmx, {step-1}] + Extract[cmx, {1}])}];
ListPlot[cmxvel, PlotStyle → RGBColor[0, 0, 0], PlotLabel → "y velocity of total CM"
cmxacc = Flatten[{(1/2) * (-Extract[cmxvel, {-1}] + Extract[cmxvel, {2}]),
  ParallelTable[(1/2) * (-Extract[cmxvel, {i-1}] + Extract[cmxvel, {i-step}]),
  {i, 2, step-1}], (1/2) * (-Extract[cmxvel, {step-1}] + Extract[cmxvel, {1}])}];
ListPlot[cmxacc, PlotStyle → RGBColor[0, 0, 0], PlotLabel → "y acceleration of total CM"
cmvel = Sqrt[cmxvel^2 + cmxacc^2];
ListPlot[cmvel, PlotStyle → RGBColor[0, 0, 0],
  PlotLabel → "magnitude of velocity of total CM"
cmacc = Sqrt[cmxacc^2 + cmxvel^2];
ListPlot[cmacc, PlotStyle → RGBColor[0, 0, 0],
  PlotLabel → "magnitude of acceleration of total CM"

```

(*TOTAL CM OF CRANK PAIR*)

```
Partition[cmx, step / 2];
revcmx = Flatten[Reverse[Partition[cmx, step / 2], 2]];
revcmx2 = Insert[revcmx, Extract[revcmx, {step}], 1];
pcmx = Delete[revcmx2, step + 1]; (*the last four lines rearrange the original
matrix so that it describes the leg pair and is reused throughout this section*)
ListPlot[cmx]; (*plot the x position of cm of leg 1*)
ListPlot[-pcmx]; (*plot the x position of cm of leg 2*)
ListPlot[Thread[{phi, (cmx - pcmx) / 2}], PlotStyle -> RGBColor[0, 0, 0],
PlotLabel -> "x position of leg pair total cm"] (*plot the total x cm for both legs*)
```

(*the y cm manipulation follows directly from the x*)

```
Partition[cmx, step / 2];
revcmx = Flatten[Reverse[Partition[cmx, step / 2], 2]];
revcmx2 = Insert[revcmx, Extract[revcmx, {step}], 1];
pcmx = Delete[revcmx2, step + 1];
ListPlot[cmx];
ListPlot[pcmx];
ListPlot[Thread[{phi, (cmx + pcmx) / 2}], PlotStyle -> RGBColor[0, 0, 0],
PlotLabel -> "y position of leg pair total cm"] (*plot the total y cm for both legs*)
```

```
cm = ListPlot[Thread[{cmx, cmx}], PlotStyle -> RGBColor[0, 0, 0]]; (*plot cm of leg 1*)
pcm = ListPlot[Thread[{-pcmx, pcmx}], PlotStyle -> RGBColor[0, 0, 0]]; (*plot cm of leg 2*)
totcm = ListPlot[Thread[{(cmx - pcmx) / 2, (cmx + pcmx) / 2}], PlotStyle -> RGBColor[0, 0, 1]]
(*plot total cm of leg pair*)
Show[leg, legpair, totcm, cm, pcm,
AspectRatio -> Automatic, PlotRange -> {{-120, 120}, {-100, 40}}]
(*show three previous plots together with pair of legs at time "example"*)
Show[ListLinePlot[ParallelTable[{{Extract[cmx, {i}], Extract[cmx, {i}]},
{-Extract[pcm, {i}], Extract[pcm, {i}]}}, {i, step}], PlotStyle -> RGBColor[0, 0, 0]],
totcm] (*check that the total cm plots lie at the center of the
line connecting cm to cm pair*)
```

(*TOTAL CM OF THREE PAIRS OF LEGS OFFSET BY 120 DEGREES*)

```

cmxpart = Partition[(cmx - pcmx) / 2, step / 3];
(*manipulate original cmx to crate phase shifted arrays*)
cmxphase = Delete[Insert[cmxpart, Extract[cmxpart, {3}], 1], 4];
cmxphase2 = Delete[Insert[cmxphase, Extract[cmxphase, {3}], 1], 4];
cmxphase0 = Flatten[cmxphase]; (*120 degree phase shift*)
cmxphase20 = Flatten[cmxphase2]; (*240 degree phase shift*)
cmxphasefinal = ((cmx - pcmx) / 2 + cmxphase0 + cmxphase20) / 3; (*total cm of three pairs*)
Show[ListPlot[Thread[{phi, (cmx - pcmx) / 2}], PlotStyle -> RGBColor[0, 0, 0]],
  ListPlot[Thread[{phi, cmxphase0}], PlotStyle -> RGBColor[0, 0, 0]],
  ListPlot[Thread[{phi, cmxphase20}], PlotStyle -> RGBColor[0, 0, 0]],
  ListPlot[Thread[{phi, cmxphasefinal}], PlotStyle -> RGBColor[0, 0, 1]],
  PlotLabel -> "x position of 120 degree phased legs" (*plot all four*)

cmypart = Partition[(cmy + pcmy) / 2, step / 3];
(*manipulate original cmy to crate phase shifted arrays*)
cmypart = Delete[Insert[cmypart, Extract[cmypart, {3}], 1], 4];
cmypart2 = Delete[Insert[cmypart, Extract[cmypart, {3}], 1], 4];
cmypart0 = Flatten[cmypart]; (*120 degree phase shift*)
cmypart20 = Flatten[cmypart2]; (*240 degree phase shift*)
cmypartfinal = ((cmy + pcmy) / 2 + cmypart0 + cmypart20) / 3; (*total cm of three pairs*)
Show[ListPlot[Thread[{phi, (cmy + pcmy) / 2}], PlotStyle -> RGBColor[0, 0, 0]],
  ListPlot[Thread[{phi, cmypart0}], PlotStyle -> RGBColor[0, 0, 0]],
  ListPlot[Thread[{phi, cmypart20}], PlotStyle -> RGBColor[0, 0, 0]],
  ListPlot[Thread[{phi, cmypartfinal}], PlotStyle -> RGBColor[0, 0, 1]],
  PlotLabel -> "y position of 120 degree phased legs" (*plot all four*)

ListPlot[Thread[{cmxphasefinal, cmypartfinal}], AspectRatio -> Automatic] (*plot position*)
Show[leg, legpair, ListPlot[Thread[{cmxphasefinal, cmypartfinal}],
  cm, pcm, AspectRatio -> Automatic, PlotRange -> {{-120, 120}, {-100, 40}}]
  (*plot position of cm with legs and individual cms of legs*)

```

(*CALCULATION OF KINETIC AND POTENTIAL ENERGY FOR THEO JANSEN MECHANISM*)

```

phi = Table[i, {i, 0, (2 Pi - 2 Pi / step), 2 Pi / step}]; (*angular position of crank*)

(*potential energy calculation:

```

multiply y position of CM of each link by mass and acceleration due to gravity,
here I let each unit of length equal one kg*)

```
grav = 9.8; (*acceleration due to gravity*)
```

```
(*kinetic energy calculation:  
superposition of rotational and translational kinetic energy of each part of link*)
```

```
(*rotational kinetic energy =  
1/2*(moment of inertia)*(angular velocity)^2 moment of inertia of a rod =  
mass*length^2 = length^3 in this case mass is proportional to length  
translational kinetic energy = (1/2)*m*v^2 *)
```

```
(*crank calculations*)
```

```
ket0x = 0; (*zero x translational kinetic energy*)  
ket0y = 0; (*zero y translational kinetic energy*)  
omega0 = 2 * Pi / step;  
ker0 = (1 / 2) * (1 / 3) * m^3 * omega0^2; (*rotational kinetic energy*)  
ke0 = Table[ket0x + ket0y + ker0, {step}]; (*total kinetic energy*)  
pe0 = cmzeroone * grav * m; (*use CM to calculate potential energy*)  
e0 = ke0 + pe0; (*total energy, check that this is constant*)  
ListPlot[ke0, PlotLabel -> "KE01", PlotStyle -> RGBColor[0, 0, 0]]  
ListPlot[pe0, PlotLabel -> "PE01", PlotStyle -> RGBColor[0, 0, 0]]  
ListPlot[e0, PlotLabel -> "Total energy of link between points 0 and 1",  
PlotStyle -> RGBColor[0, 0, 0]] (*plot total energy*)
```

```
(*baronetwo calculations*)
```

```
ket1x = (1 / 2) * r * (-m * Sin[phi])^2;  
(*translational kinetic energy: x translational velocity = derivative of xone*)  
ket1y = (1 / 2) * r * (m * Cos[phi])^2;  
(*translational kinetic energy: y translational velocity = derivative of yone*)  
int1 := ParallelTable[  
Solve[{xone[Extract[phi, {i}]] + r * Cos[intomegal] == xtwo[Extract[z2o, {i}]], intomegal],  
{i, step}]; (*solve for the position of the angle of rotation of link at point one*)  
intomegal2 = intomegal /. int1;  
intomegal10 = Flatten[intomegal2];  
intomegal0 = Select[intomegal10, 0 < # &]; (*remove extraneous solutions*)  
omega1 = Flatten[{(1 / 2) * ((Extract[intomegal0, {1}] - Extract[intomegal0, {-1}]) +  
(Extract[intomegal0, {2}] - Extract[intomegal0, {1}]))},  
ParallelTable[(1 / 2) * ((Extract[intomegal0, {i}] - Extract[intomegal0, {i - 1}]) +  
(Extract[intomegal0, {i - step}] - Extract[intomegal0, {i}]))], {i, 2, step - 1}],  
(1 / 2) * ((Extract[intomegal0, {step}] - Extract[intomegal0, {step - 1}]) +  
(Extract[intomegal0, {1}] - Extract[intomegal0, {step}]))}];  
(*solve for angular velocity at time step i by averaging the  
slope between steps i and i-  
1 with the slope of steps i and i+  
1*)  
ListPlot[omega1, PlotStyle -> RGBColor[0, 0, 0]]  
ListPlot[intomegal0, PlotStyle -> RGBColor[0, 0, 0]]  
ker1 = (1 / 2) * (1 / 3) * r^3 * omega1^2; (*rotational kinetic energy*)
```

```

ket1 = ket1x + ket1y + ker1; (*total kinetic energy*)
ListPlot[ket1, PlotLabel → "KE12", PlotStyle → RGBColor[0, 0, 0]]
(*plot total kinetic energy for one locomotive cycle*)
pe1 = cmyonetwo * grav * r; (*potential energy*)
ListPlot[pe1, PlotLabel → "PE12", PlotStyle → RGBColor[0, 0, 0]]
(*translational kinetic energy*)
e1 = ket1 + pe1; (*total energy*)
(*ListPlot[ket1, pe1, e1]; *)
ListPlot[e1, PlotStyle → RGBColor[0, 0, 0],
PlotLabel → "total energy of link between points 1 and 2"] (*plot total energy*)

(*bartwothree calculations*)
ket2x = 0; (*point three is stationary*)
ket2y = 0;
intomega2o := z2o; (*position of the angle of rotation of link at point three*)
omega2 = Flatten[{(1/2) * ((Extract[intomega2o, {1}] - Extract[intomega2o, {-1}]) +
(Extract[intomega2o, {2}] - Extract[intomega2o, {1}])),
ParallelTable[(1/2) * ((Extract[intomega2o, {i}] - Extract[intomega2o, {i-1}]) +
(Extract[intomega2o, {i-step}] - Extract[intomega2o, {i}))), {i, 2, step-1}],
(1/2) * ((Extract[intomega2o, {step}] - Extract[intomega2o, {step-1}]) +
(Extract[intomega2o, {1}] - Extract[intomega2o, {step}])))];
(*solve for angular velocity at time step i by averaging the
slope between steps i and i-
1 with the slope of steps i and i+
1*)
ListPlot[omega2, PlotLabel → "omega2", PlotStyle → RGBColor[0, 0, 0]]
ListPlot[intomega2o, PlotLabel → "intomega2", PlotStyle → RGBColor[0, 0, 0]]
ker2 = (1/2) * b^3 * omega2^2; (*rotational kinetic energy*)
ke2 = ket2x + ket2y + ker2; (*total kinetic energy*)
ListPlot[ke2, PlotLabel → "KE23", PlotStyle → RGBColor[0, 0, 0]]
(*plot total kinetic energy for one locomotive cycle*)
pe2 = cmytwothree[z2o] * grav * b; (*potential energy*)
ListPlot[pe2, PlotLabel → "PE23", PlotStyle → RGBColor[0, 0, 0]]
(*translational kinetic energy*)
e2 = ke2 + pe2; (*total energy*)
ListPlot[e2, PlotStyle → RGBColor[0, 0, 0],
PlotLabel → "total energy of link between points 2 and 3"] (*plot total energy*)

(*barfivethree calculations*)
ket5x = 0; (*point three is stationary*)
ket5y = 0;
intomega5o = y2o; (*position of the angle of rotation of link at point three*)
omega5 = Flatten[{(1/2) * ((Extract[intomega5o, {1}] - Extract[intomega5o, {-1}]) +
(Extract[intomega5o, {2}] - Extract[intomega5o, {1}])),
ParallelTable[(1/2) * ((Extract[intomega5o, {i}] - Extract[intomega5o, {i-1}]) +
(Extract[intomega5o, {i-step}] - Extract[intomega5o, {i}))), {i, 2, step-1}],
(1/2) * ((Extract[intomega5o, {step}] - Extract[intomega5o, {step-1}]) +
(Extract[intomega5o, {1}] - Extract[intomega5o, {step}])))];
(*solve for angular velocity at time step i by averaging the

```

```

    slope between steps i and i-
  1 with the slope of steps i and i+
  1*)
ListPlot[omega5, PlotLabel -> "omega5", PlotStyle -> RGBColor[0, 0, 0]]
ListPlot[intomega5o, PlotLabel -> "intomega5", PlotStyle -> RGBColor[0, 0, 0]]
ker5 = (1/2) * (1/3) * c^3 * omega5^2; (*rotational kinetic energy*)
ke5 = ket5x + ket5y + ker5; (*total kinetic energy*)
ListPlot[ke5, PlotLabel -> "KE35", PlotStyle -> RGBColor[0, 0, 0],
  PlotRange -> {{0, step}, {0, 400}}] (*plot total kinetic energy for one locomotive cycle*)
pe5 = cmyfivethree[y2o] * grav * c; (*potential energy*)
ListPlot[pe5, PlotLabel -> "PE35", PlotStyle -> RGBColor[0, 0, 0]]
(*translational kinetic energy*)
e5 = ke5 + pe5; (*total energy*)
ListPlot[e5, PlotStyle -> RGBColor[0, 0, 0],
  PlotLabel -> "total energy of link between points 3 and 5"] (*plot total energy*)

(*bartwofour calculations*)
ket6x = xtwovel; (*point three is stationary*)
ket6y = ytwovel;
int6 := ParallelTable[
  Solve[{xtwo[Extract[z2o, {i}]] + e * Cos[intomega6] == xfour[Extract[x2o, {i}]]}, intomega6],
  {i, step}]
intomega6o = Flatten[intomega6 /. int6]; (*position of the
  angle of rotation of link at point two*)
intomega6o = Select[intomega6o, # < 0 &]; (*remove extraneous solutions*)
omega6 = Flatten[{{(1/2) * ((Extract[intomega6o, {1}] - Extract[intomega6o, {-1}]) +
  (Extract[intomega6o, {2}] - Extract[intomega6o, {1}]}),
  ParallelTable[(1/2) * ((Extract[intomega6o, {i}] - Extract[intomega6o, {i-1}]) +
  (Extract[intomega6o, {i-step}] - Extract[intomega6o, {i}]}), {i, 2, step-1}],
  (1/2) * ((Extract[intomega6o, {step}] - Extract[intomega6o, {step-1}]) +
  (Extract[intomega6o, {1}] - Extract[intomega6o, {step}]))}]]];
(*solve for angular velocity at time step i by averaging the
  slope between steps i and i-
  1 with the slope of steps i and i+
  1*)
ListPlot[omega6, PlotLabel -> "omega6", PlotStyle -> RGBColor[0, 0, 0]]
ListPlot[intomega6o, PlotLabel -> "intomega6", PlotStyle -> RGBColor[0, 0, 0]]
ker6 = (1/2) * (1/3) * e^3 * omega6^2; (*rotational kinetic energy*)
ke6 = ket6x + ket6y + ker6; (*total kinetic energy*)
ListPlot[ke6, PlotLabel -> "KE24", PlotStyle -> RGBColor[0, 0, 0]]
(*plot total kinetic energy for one locomotive cycle*)
pe6 = cmytwofour * grav * e; (*potential energy*)
ListPlot[pe6, PlotLabel -> "PE24", PlotStyle -> RGBColor[0, 0, 0]]
(*translational kinetic energy*)
e6 = ke6 + pe6; (*total energy*)
ListPlot[e6, PlotStyle -> RGBColor[0, 0, 0],
  PlotLabel -> "total energy of link between points 2 and 4"] (*plot total energy*)

(*barfiveone calculations*)

```

```

ket7x = xonevel; (*point three is stationary*)
ket7y = yonevel;
int7 := ParallelTable[
  Solve[{xone[Extract[phi, {i}]] + k * Cos[intomega7] == xfive[Extract[y2o, {i}]]}, intomega7],
  {i, step}]
intomega70 = Flatten[intomega7 /. int7]; (*position of the
  angle of rotation of link at point one*)
intomega7o = Select[intomega70, # < 0 &]; (*remove extraneous solutions*)
omega7 = Flatten[{(1/2) * ((Extract[intomega7o, {1}] - Extract[intomega7o, {-1}]) +
  (Extract[intomega7o, {2}] - Extract[intomega7o, {1}))),
  ParallelTable[(1/2) * ((Extract[intomega7o, {i}] - Extract[intomega7o, {i-1}]) +
  (Extract[intomega7o, {i-step}] - Extract[intomega7o, {i}))), {i, 2, step-1}],
  (1/2) * ((Extract[intomega7o, {step}] - Extract[intomega7o, {step-1}]) +
  (Extract[intomega7o, {1}] - Extract[intomega7o, {step}]))}];
(*solve for angular velocity at time step i by averaging the
  slope between steps i and i-
  1 with the slope of steps i and i+
  1*)
ListPlot[omega7, PlotLabel -> "omega7", PlotStyle -> RGBColor[0, 0, 0]]
ListPlot[intomega7o, PlotLabel -> "intomega7", PlotStyle -> RGBColor[0, 0, 0]]
ker7 = (1/2) * (1/3) * k^3 * omega7^2; (*rotational kinetic energy*)
ke7 = ket7x + ket7y + ker7; (*total kinetic energy*)
ListPlot[ke7, PlotLabel -> "KE15", PlotStyle -> RGBColor[0, 0, 0],
  PlotRange -> {{0, step}, {0, 800}}] (*plot total kinetic energy for one locomotive cycle*)
pe7 = cmyonefive * grav * k; (*potential energy*)
ListPlot[pe7, PlotLabel -> "PE15", PlotStyle -> RGBColor[0, 0, 0]]
(*translational kinetic energy*)
e7 = ke7 + pe7; (*total energy*)
ListPlot[e7, PlotStyle -> RGBColor[0, 0, 0],
  PlotLabel -> "total energy of link between points 1 and 5"] (*plot total energy*)

(*barfoursix calculations*)
ket8x = xfourvel; (*point three is stationary*)
ket8y = yfourvel;
intomega8o = w2o;
omega8 = Flatten[{(1/2) * ((Extract[intomega8o, {1}] - Extract[intomega8o, {-1}]) +
  (Extract[intomega8o, {2}] - Extract[intomega8o, {1}))),
  ParallelTable[(1/2) * ((Extract[intomega8o, {i}] - Extract[intomega8o, {i-1}]) +
  (Extract[intomega8o, {i-step}] - Extract[intomega8o, {i}))), {i, 2, step-1}],
  (1/2) * ((Extract[intomega8o, {step}] - Extract[intomega8o, {step-1}]) +
  (Extract[intomega8o, {1}] - Extract[intomega8o, {step}]))}];
(*solve for angular velocity at time step i by averaging the
  slope between steps i and i-
  1 with the slope of steps i and i+
  1*)
ListPlot[omega8, PlotLabel -> "omega8", PlotStyle -> RGBColor[0, 0, 0]]
ListPlot[intomega8o, PlotLabel -> "intomega8", PlotStyle -> RGBColor[0, 0, 0]]
ker8 = (1/2) * (1/3) * f^3 * omega8^2; (*rotational kinetic energy*)
ke8 = ket8x + ket8y + ker8; (*total kinetic energy*)
ListPlot[ke8, PlotLabel -> "KE46", PlotStyle -> RGBColor[0, 0, 0]]

```

```

(*plot total kinetic energy for one locomotive cycle*)
pe8 = cmyfoursix * grav * f; (*potential energy*)
ListPlot[pe8, PlotLabel → "PE46", PlotStyle → RGBColor[0, 0, 0]]
(*translational kinetic energy*)
e8 = ke8 + pe8; (*total energy*)
ListPlot[e8, PlotStyle → RGBColor[0, 0, 0],
  PlotLabel → "total energy of link between points 4 and 6"] (*plot total energy*)

(*barfivesix calculations*)
ket9x = xfivevel; (*point three is stationary*)
ket9y = yfivevel;
int9 := ParallelTable[Solve[{yfive[Extract[y2o, {i}]] + g * Sin[intomega9] ==
  yfour[Extract[x2o, {i}]] + f * Sin[Extract[w2o, {i}]]}, intomega9], {i, step}]
intomega9o = Flatten[intomega9 /. int9]; (*position of the angle of
rotation of link at point five*)
intomega9o = -intomega9o + Pi;
omega9 = Flatten[{(1/2) * ((Extract[intomega9o, {1}] - Extract[intomega9o, {-1}]) +
  (Extract[intomega9o, {2}] - Extract[intomega9o, {1}])),
  ParallelTable[(1/2) * ((Extract[intomega9o, {i}] - Extract[intomega9o, {i-1}]) +
  (Extract[intomega9o, {i-step}] - Extract[intomega9o, {i}])), {i, 2, step-1}],
  (1/2) * ((Extract[intomega9o, {step}] - Extract[intomega9o, {step-1}]) +
  (Extract[intomega9o, {1}] - Extract[intomega9o, {step}]))}];
(*solve for angular velocity at time step i by averaging the
slope between steps i and i-
1 with the slope of steps i and i+
1*)
ListPlot[omega9, PlotLabel → "omega9", PlotStyle → RGBColor[0, 0, 0]]
ListPlot[intomega9o, PlotLabel → "intomega9", PlotStyle → RGBColor[0, 0, 0]]
ker9 = (1/2) * (1/3) * g^3 * omega9^2; (*rotational kinetic energy*)
ke9 = ket9x + ket9y + ker9; (*total kinetic energy*)
ListPlot[ke9, PlotLabel → "KE56", PlotStyle → RGBColor[0, 0, 0]]
(*plot total kinetic energy for one locomotive cycle*)
pe9 = cmyfivesix * grav * g; (*potential energy*)
ListPlot[pe9, PlotLabel → "PE56", PlotStyle → RGBColor[0, 0, 0]]
(*translational kinetic energy*)
e9 = ke9 + pe9; (*total energy*)
ListPlot[e9, PlotStyle → RGBColor[0, 0, 0],
  PlotLabel → "total energy of link between points 5 and 6"] (*plot total energy*)

(*barfiveseven calculations*)
ket10x = xfivevel; (*point three is stationary*)
ket10y = yfivevel;
int10 := ParallelTable[
  Solve[{xfive[Extract[y2o, {i}]] + o * Cos[intomegaten] == Extract[x7o, {i}]}, intomegaten],
  {i, step}]
intomega10o = Flatten[intomegaten /. int10];
(*position of the angle of rotation of link at point five*)
intomega10o = Select[intomega10o, # < 0 &];
omega10 = Flatten[{(1/2) * ((Extract[intomega10o, {1}] - Extract[intomega10o, {-1}]) +

```

```

      (Extract[intomegal0o, {2}] - Extract[intomegal0o, {1}]),
      ParallelTable[(1/2) * ((Extract[intomegal0o, {i}] - Extract[intomegal0o, {i-1}]) +
        (Extract[intomegal0o, {i-step}] - Extract[intomegal0o, {i}]), {i, 2, step-1}],
      (1/2) * ((Extract[intomegal0o, {step}] - Extract[intomegal0o, {step-1}]) +
        (Extract[intomegal0o, {1}] - Extract[intomegal0o, {step}]))];
    (*solve for angular velocity at time step i by averaging the
      slope between steps i and i-
      1 with the slope of steps i and i+
      1*)
  ListPlot[omega10, PlotLabel -> "omega10", PlotStyle -> RGBColor[0, 0, 0]]
  ListPlot[intomegal0o, PlotLabel -> "intomegal0", PlotStyle -> RGBColor[0, 0, 0]]
  ker10 = (1/2) * (1/3) * o^3 * omega10^2; (*rotational kinetic energy*)
  ke10 = ket10x + ket10y + ker10; (*total kinetic energy*)
  ListPlot[ke10, PlotLabel -> "KE57", PlotStyle -> RGBColor[0, 0, 0],
    PlotRange -> {{0, step}, {0, 400}}] (*plot total kinetic energy for one locomotive cycle*)
  pe10 = cmysevenfive * grav * o; (*potential energy*)
  ListPlot[pe10, PlotLabel -> "PE57", PlotStyle -> RGBColor[0, 0, 0]]
  (*translational kinetic energy*)
  e10 = ke10 + pe10; (*total energy*)
  ListPlot[e10, PlotStyle -> RGBColor[0, 0, 0],
    PlotLabel -> "total energy of link between points 5 and 7"] (*plot total energy*)

  (*barsixseven calculations*)
  ket11x = xsevenvel; (*point three is stationary*)
  ket11y = ysevenvel;
  int11 := ParallelTable[Solve[{Extract[x7o, {i}] + h * Cos[intomegal11] ==
    xfour[Extract[x2o, {i}]] + f * Cos[Extract[w2o, {i}]]}], intomegal11, {i, step}]
  intomegal10 = Flatten[intomegal11 /. int11]; (*position of the angle
    of rotation of link at point seven*)
  intomegal10 = Select[intomegal10, # < 0 &];
  omega11 = Flatten[{(1/2) * ((Extract[intomegal10, {1}] - Extract[intomegal10, {-1}]) +
    (Extract[intomegal10, {2}] - Extract[intomegal10, {1}]),
    ParallelTable[(1/2) * ((Extract[intomegal10, {i}] - Extract[intomegal10, {i-1}]) +
      (Extract[intomegal10, {i-step}] - Extract[intomegal10, {i}]), {i, 2, step-1}],
    (1/2) * ((Extract[intomegal10, {step}] - Extract[intomegal10, {step-1}]) +
      (Extract[intomegal10, {1}] - Extract[intomegal10, {step}])))];
    (*solve for angular velocity at time step i by averaging the
      slope between steps i and i-
      1 with the slope of steps i and i+
      1*)
  ListPlot[omega11, PlotLabel -> "omega11", PlotStyle -> RGBColor[0, 0, 0]]
  ListPlot[intomegal10, PlotLabel -> "intomegal1", PlotStyle -> RGBColor[0, 0, 0]]
  ker11 = (1/2) * (1/3) * h^3 * omega11^2; (*rotational kinetic energy*)
  ke11 = ket11x + ket11y + ker11; (*total kinetic energy*)
  ListPlot[ke11, PlotLabel -> "KE67", PlotStyle -> RGBColor[0, 0, 0],
    PlotRange -> {{0, step}, {0, 1000}}] (*plot total kinetic energy for one locomotive cycle*)
  pe11 = cmysevensix * grav * h; (*potential energy*)
  ListPlot[pe11, PlotLabel -> "PE67", PlotStyle -> RGBColor[0, 0, 0]]
  (*translational kinetic energy*)

```



```
e11 = ke11 + pe11; (*total energy*)
ListPlot[e11, PlotStyle -> RGBColor[0, 0, 0],
PlotLabel -> "total energy of link between points 6 and 7"] (*plot total energy*)
```

```
(*CHEBYSHEV LINKAGE*)
```

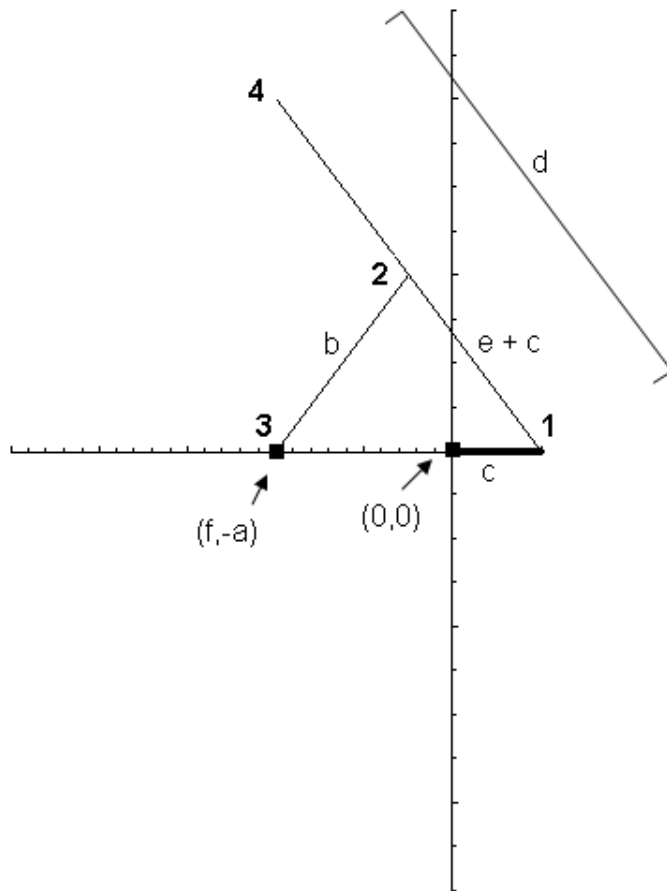

```
a = 2;
b = 2.5;
c = 1;
d = 5;
e = Sqrt[(b^2 - a^2)];
```

```

f = 0;
g = 2;
h = 5;
k = 2.5;
l = 3;
step = 24;

(*position of crank*)
phi = Table[i, {i, 0, (2 Pi - 2 Pi / step), 2 Pi / step}];
xone = ParallelTable[c * Cos[Extract[phi, {i}]], {i, step}];
yone = ParallelTable[c * Sin[Extract[phi, {i}]], {i, step}];
one = ListPlot[Thread[{xone, yone}], AspectRatio -> Automatic,
  PlotStyle -> RGBColor[0, 0, 0], PlotRange -> {{-5, 1}, {-1, 5}}]
  (*Plot of position of crank for one locomotive cycle*)

(*position of fixed point 3*)
xthree = -a;
ythree = f;
x3 = Table[xthree, {step}];
y3 = Table[ythree, {step}];

(*position of point two*)
xtwo[thetaone_] := xthree + b * Cos[thetaone];
ytwo[thetaone_] := ythree + b * Sin[thetaone];
s := ParallelTable[
  Solve[{(e + c)^2 == (xtwo[z] - Extract[xone, {i}])^2 + (ytwo[z] - Extract[yone, {i}])^2}, z],
  {i, step}]; (*solve equation for theta 1 for all time steps*)
z2o = Select[Flatten[z /. s], # > 0 &]; two = ListPlot[Thread[{xtwo[z2o], ytwo[z2o]}],
  PlotLabel -> "position two", AspectRatio -> Automatic, PlotStyle -> RGBColor[0, 0, 0],
  PlotRange -> {{-5, 1}, {-1, 5}}] (*position plot for entire locomotive cycle*)

thetatwo = ParallelTable[
  ArcCos[1 / (e + c) * (xtwo[Extract[z2o, {i}]] - c * Cos[Extract[phi, {i}]])], {i, step}];
ListPlot[thetatwo];
xfour = ParallelTable[c * Cos[Extract[phi, {i}]] + d * Cos[Extract[thetatwo, {i}]], {i, step}];
yfour = ParallelTable[c * Sin[Extract[phi, {i}]] + d * Sin[Extract[thetatwo, {i}]], {i, step}];
four = ListPlot[Thread[{xfour, yfour}], AspectRatio -> Automatic,
  PlotStyle -> RGBColor[0, 0, 0], PlotRange -> {{-5, 1}, {-1, 5}}]

Show[one, two, four]

link =
  ListLinePlot[Flatten[{{Extract[xone, {1}], Extract[yone, {1}]}, {xtwo[Extract[z2o, {1}]],
    ytwo[Extract[z2o, {1}]]}, {xthree, ythree}}, {{xtwo[Extract[z2o, {1}]],
    ytwo[Extract[z2o, {1}]]}, {Extract[xfour, {1}], Extract[yfour, {1}]}}, 1],
  AspectRatio -> Automatic, PlotStyle -> RGBColor[0, 0, 0], PlotRange -> {{-5, 1}, {-1, 5}}]

Show[link, one, four]

```



```

l = 2.5;
m = 2.5;
n = 5;
step = 24;

(*position of crank*)
phi = Table[i, {i, 0, (2 Pi - 2 Pi / step), 2 Pi / step}];
xone = ParallelTable[c * Cos[Extract[phi, {i}]], {i, step}];
yone = ParallelTable[c * Sin[Extract[phi, {i}]], {i, step}];
one = ListPlot[Thread[{xone, yone}], AspectRatio → Automatic,
  PlotStyle → RGBColor[0, 0, 0], PlotRange → {{-5, 2}, {2, -12}}]
  (*Plot of position of crank for one locomotive cycle*)

(*position of fixed point 3*)
xthree = -a;
ythree = 0;
x3 = Table[xthree, {step}];
y3 = Table[ythree, {step}];

(*position of point two*)
xtwo[thetaone_] := xthree + b * Cos[thetaone];
ytwo[thetaone_] := ythree + b * Sin[thetaone];
s := ParallelTable[
  Solve[{(e + c) ^ 2 == (xtwo[z] - Extract[xone, {i}]) ^ 2 + (ytwo[z] - Extract[yone, {i}]) ^ 2}, z],
  {i, step}]; (*solve equation for theta 1 for all time steps*)
z2o = Select[Flatten[z /. s], # < 0 &]; two = ListPlot[Thread[{xtwo[z2o], ytwo[z2o]}],
  PlotLabel → "position two", AspectRatio → Automatic,
  PlotStyle → RGBColor[0, 0, 0], PlotRange → {{-5, 2}, {2, -12}}]
ListPlot[xtwo[z2o], PlotLabel → "position two x"]
ListPlot[ytwo[z2o], PlotLabel → "position two y"]

z2oo = Select[Flatten[z /. s], # > 0 &];
ListPlot[Thread[{xtwo[z2oo], ytwo[z2oo]}], PlotLabel → "position two pos",
  AspectRatio → Automatic, PlotStyle → RGBColor[0, 0, 0], PlotRange → {{-5, 2}, {5, -12}}]
ListPlot[xtwo[z2oo], PlotLabel → "position two x pos"]
ListPlot[ytwo[z2oo], PlotLabel → "position two y pos"]

z2ooo = z2oo - Pi / 2
ListPlot[Thread[{xtwo[z2ooo], ytwo[z2ooo]}], PlotLabel → "position two pos",
  AspectRatio → Automatic, PlotStyle → RGBColor[0, 0, 0], PlotRange → {{-5, 2}, {5, -12}}]
ListPlot[xtwo[z2ooo], PlotLabel → "position two x pos2"]
ListPlot[ytwo[z2ooo], PlotLabel → "position two y pos2"]
(*position plot for entire locomotive cycle*)

thetatwo = -ParallelTable[
  ArcCos[1 / (e + c) * (xtwo[Extract[z2o, {i}]] - c * Cos[Extract[phi, {i}]])], {i, step}];
ListPlot[thetatwo];
xfour = ParallelTable[c * Cos[Extract[phi, {i}]] + d * Cos[Extract[thetatwo, {i}]], {i, step}];

```

```

yfour = ParallelTable[c * Sin[Extract[phi, {i}]] + d * Sin[Extract[thetatwo, {i}]], {i, step}];
four = ListPlot[Thread[{xfour, yfour}], AspectRatio → Automatic,
  PlotStyle → RGBColor[0, 0, 0], PlotRange → {{-5, 2}, {2, -12}}]

(*fixed point 6*)
xsix = -a;
ysix = k;

(*position of hinge 7*)
xseven[thetathree_] := xsix + h * Cos[thetathree];
yseven[thetathree_] := ysix + h * Sin[thetathree];
s := ParallelTable[
  Solve[{(1)^2 == (xseven[w] - Extract[xfour, {i}])^2 + (yseven[w] - Extract[yfour, {i}])^2},
    w], {i, step}];
w2o = Delete[Flatten[w / . s], ParallelTable[{2 * i}, {i, step}]];
ListPlot[w2o, PlotLabel → "seven"]
(*ListPlot[w2o-Pi, PlotLabel→"nine"*)
x7 = Flatten[ParallelTable[xseven[Extract[w2o, {i}]], {i, step}]];
y7 = Flatten[ParallelTable[yseven[Extract[w2o, {i}]], {i, step}]];
seven = ListPlot[Thread[{x7, y7}], AspectRatio → Automatic,
  PlotStyle → RGBColor[0, 0, 0], PlotRange → {{-5, 2}, {2, -10}}]

(*position of hinge 8*)
v2o = Delete[Flatten[w / . s], ParallelTable[{2 * i - 1}, {i, step}]];
ListPlot[v2o, PlotLabel → "eight", PlotStyle → RGBColor[1, 0, 0]]
(*ListPlot[v2o-Pi, PlotLabel→"ten", PlotStyle→RGBColor[1,0,0]*)
x8 = Flatten[ParallelTable[xseven[Extract[v2o, {i}]], {i, step}]];
y8 = Flatten[ParallelTable[yseven[Extract[v2o, {i}]], {i, step}]];
eight = ListPlot[Thread[{x8, y8}], AspectRatio → Automatic,
  PlotStyle → RGBColor[0, 0, 0], PlotRange → {{-5, 2}, {2, -12}}]

(*position of hinge 9*)
x9 = 2 * xsix - x7;
ListPlot[x9]
y9 = 2 * ysix - y7;
ListPlot[y9, PlotLabel → "y9"]
nine = ListPlot[Thread[{x9, y9}], AspectRatio → Automatic,
  PlotStyle → RGBColor[0, 0, 0], PlotRange → {{-5, 2}, {2, -12}}, PlotLabel → "nine"]

(*position of hinge 10*)
x10 = 2 * xsix - x8;
ListPlot[x10]
y10 = 2 * ysix - y8;
ListPlot[y10, PlotLabel → "y10"]
ten = ListPlot[Thread[{x10, y10}], AspectRatio → Automatic,
  PlotStyle → RGBColor[0, 0, 0], PlotRange → {{-5, 2}, {2, -12}}, PlotLabel → "ten"]

theta9 = ArcSin[(y9 - ysix) / h]
theta10 = ArcSin[(y10 - ysix) / h]
ListPlot[Thread[{phi, theta9}], PlotStyle → RGBColor[0, 0, 1], PlotLabel → "nine"]
ListPlot[Thread[{phi, theta10}], PlotStyle → RGBColor[1, 0, 0], PlotLabel → "ten"]

```

```

(*position of foot*)
s := ParallelTable[
  Solve[{(m)^2 == (Extract[x9, {i}] + m * Cos[u] - Extract[x10, {i}])^2 +
    (Extract[y9, {i}] + m * Sin[u] - Extract[y10, {i}])^2}, u, {i, step}];
ListPlot[Flatten[u /. s]]
u2 = Re[Flatten[u /. s]];
u2o = Flatten[ParallelTable[Extract[u2, {4 * i - 1}], {i, step}]]
u2oo = Flatten[ParallelTable[Extract[u2, {4 * i}], {i, step}]]
eleven = ListPlot[Thread[{x9 + m * Cos[u2o], y9 + m * Sin[u2o]}],
  AspectRatio → Automatic, PlotStyle → RGBColor[0, 0, 0], PlotRange → {{-5, 2}, {2, -12}}]
eleven2 = ListPlot[Thread[{x9 + m * Cos[u2oo], y9 + m * Sin[u2oo]}], AspectRatio → Automatic,
  PlotStyle → RGBColor[0, 0, 0], PlotRange → {{-5, 2}, {2, -12}}]

Show[one, two, four, seven, eight, nine, ten, eleven, eleven2]

(*show full leg*)
link = ListLinePlot[
  Flatten[ParallelTable[{{Extract[xone, {i}], Extract[yone, {i}]}, {xtwo[Extract[z2o, {i}]],
    ytwo[Extract[z2o, {i}]]}, {xthree, ythree}}, {{xtwo[Extract[z2o, {i}]],
    ytwo[Extract[z2o, {i}]]}, {Extract[xfour, {i}], Extract[yfour, {i}]}, {{xsix, ysix},
    {Extract[x7, {i}], Extract[y7, {i}]}, {Extract[xfour, {i}], Extract[yfour, {i}]},
    {Extract[x8, {i}], Extract[y8, {i}]}, {xsix, ysix}}, {{xsix, ysix},
    {Extract[x9, {i}], Extract[y9, {i}]}, {Extract[x11, {i}], Extract[y11, {i}]},
    {Extract[x10, {i}], Extract[y10, {i}]}, {xsix, ysix}}, {i, step}], 1],
  AspectRatio → Automatic, PlotStyle → RGBColor[0, 0, 0],
  PlotRange → {{-5, 2}, {2, -12}}]

(*FOUR BAR LINKAGE #1 OPTIMIZATION*)

```

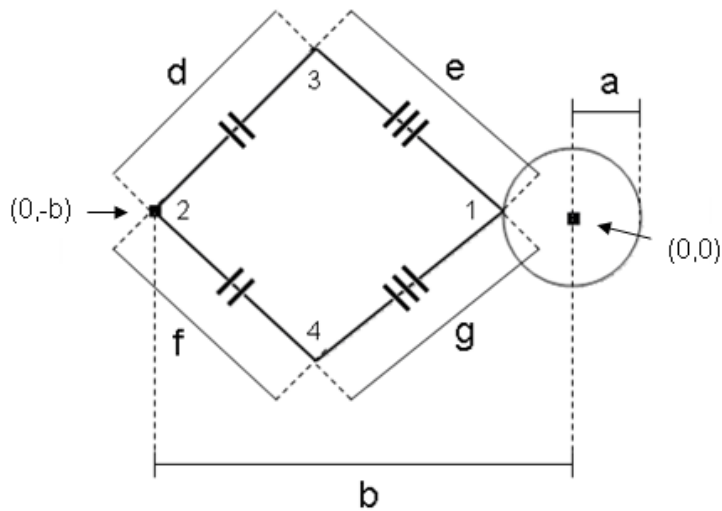

```
(*define variables*)
```

```
(*crank*)
```

```
a = 25;
```

```
(*distance of crank from hinge*)
```

```
b = 55;
```

```
(*three*)
```

```
d = 70;
```

```
e = 50;
```

```
(*four*)
```

```
f = d;
```

```
g = e;
```

```
step = 24; (*number of time steps*)
```

```
example = 10; (*time step of full linkage plots*)
```

```
(*position of crank*)
```

```
phi = Table[i, {i, 0, (2 Pi - 2 Pi / step), 2 Pi / step}];
```

```
xone = ParallelTable[a * Cos[Extract[phi, {i}]], {i, step}];
```

```
yone = ParallelTable[a * Sin[Extract[phi, {i}]], {i, step}];
```

```
one = ListPlot[Thread[{xone, yone}], AspectRatio -> Automatic,  
PlotStyle -> RGBColor[0, 0, 0], PlotRange -> {{-120, 30}, {-100, 80}}]
```

```
(*position of fixed hinge*)
```

```

xtwo = -b;
ytwo = 0;

(*hinge 3*)
xthree[thetaone_] := xtwo + d * Cos[thetaone];
ythree[thetaone_] := ytwo + d * Sin[thetaone];
s := ParallelTable[
  Solve[{(e)^2 == (xthree[z] - Extract[xone, {i}])^2 + (ythree[z] - Extract[yone, {i}])^2}, z],
  {i, step}];
ListPlot[Flatten[z /. s]]
z2 = Select[Flatten[z /. s], # > 0 &]

three = ListPlot[Thread[{xthree[z2], ythree[z2]}], PlotLabel -> "position three",
  AspectRatio -> Automatic, PlotStyle -> RGBColor[0, 0, 0], PlotRange -> {{-120, 30}, {-100, 80}}]
(*ListPlot[xthree[z2], PlotLabel -> "position three x"]
ListPlot[ythree[z2], PlotLabel -> "position three y"]*)

(*hinge four*)
xfour[thetaone_] := xtwo + f * Cos[thetaone];
yfour[thetaone_] := ytwo + f * Sin[thetaone];
s := ParallelTable[
  Solve[{(g)^2 == (xfour[y] - Extract[xone, {i}])^2 + (yfour[y] - Extract[yone, {i}])^2}, y],
  {i, step}];
ListPlot[Flatten[y /. s]]
y2 = Select[Flatten[y /. s], # < 0 &]

four = ListPlot[Thread[{xfour[y2], yfour[y2]}], PlotLabel -> "position four",
  AspectRatio -> Automatic, PlotStyle -> RGBColor[0, 0, 0], PlotRange -> {{-120, 30}, {-100, 80}}]

xxfour = N[xfour[N[y2]]];
yyfour = N[yfour[N[y2]]];

(*plots*)
thetathree =
  ListPlot[Thread[{phi, z2 - 2.2}], PlotLabel -> "theta three", PlotStyle -> RGBColor[1, 0, 0]];
thetafour = ListPlot[Thread[{phi, y2}], PlotLabel -> "theta four",
  PlotStyle -> RGBColor[0, 0, 1]];

Show[one, three, four]
Show[one, three, four]

Show[thetathree, thetathree]

(*FULL LINKAGE POSITION PLOTS*)

```

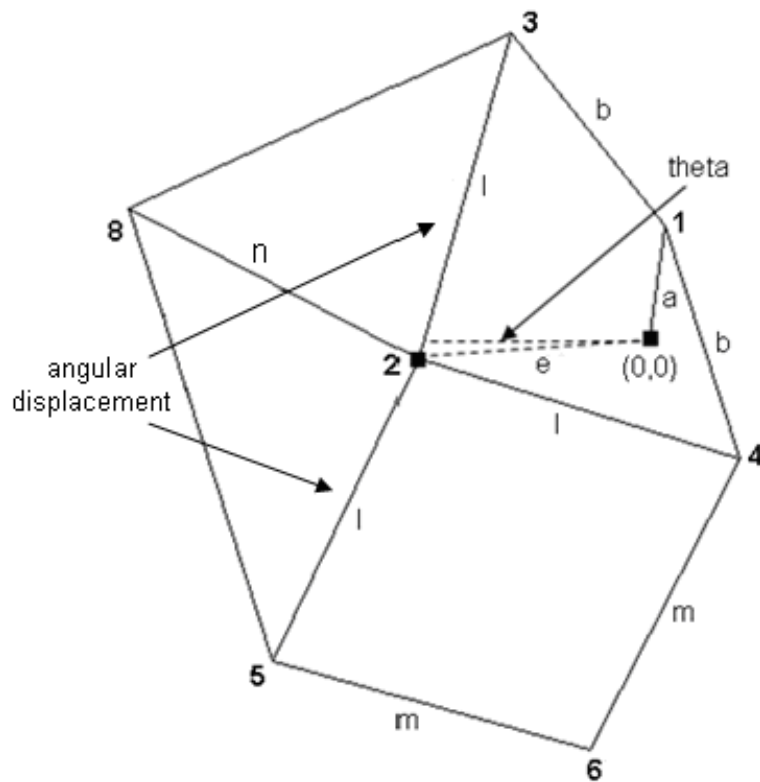
```

(*crank*)
a = 26;
(*distance of crank from hinge*)
b = 53;
theta = -Pi + .085;
(*hinge rod*)
l = 77;
(*crank rod*)
e = 56;
(*separation of foot rods*)
separation = -1.815

m = 1 - 2;
(*(*foot rod*)
l=65;*)
step = 24; (*number of time steps*)
example = 23; (*time step of full linkage plots*)

```

```

(*position of crank*)
phi = Table[i, {i, 0, (2 Pi - 2 Pi / step), 2 Pi / step}];
xone = ParallelTable[a * Cos[Extract[phi, {i}]], {i, step}];
yone = ParallelTable[a * Sin[Extract[phi, {i}]], {i, step}];
one = ListPlot[Thread[{xone, yone}], AspectRatio → Automatic,
  PlotStyle → RGBColor[0, 0, 0], PlotLabel → "angular position of crank"]
xonepos = xone;
yonepos = yone;

(*position of fixed hinge 2*)
xtwo = b * Cos[theta];
ytwo = b * Sin[theta];
xtwopos = xtwo;
ytwopos = ytwo;

(*position of hinge 3*)
xthree[thetaone_] := xtwo + 1 * Cos[thetaone];
ythree[thetaone_] := ytwo + 1 * Sin[thetaone];
s := ParallelTable[
  Solve[{(e)^2 == (xthree[z] - Extract[xone, {i}])^2 + (ythree[z] - Extract[yone, {i}])^2}, z],
  {i, step}];
ListPlot[Flatten[z /. s]]
z2 = Select[Flatten[z /. s], # > 0 &]
three = ListPlot[Thread[{xthree[z2], ythree[z2]}], PlotLabel → "position three",
  AspectRatio → Automatic, PlotStyle → RGBColor[0, 0, 0], PlotRange → {{-140, 50}, {-120, 80}}]
xthreepos = xthree[z2];
ythreepos = ythree[z2];

(*position of hinge four*)
xfour[thetaone_] := xtwo + 1 * Cos[thetaone];
yfour[thetaone_] := ytwo + 1 * Sin[thetaone];
s := ParallelTable[
  Solve[{(e)^2 == (xfour[y] - Extract[xone, {i}])^2 + (yfour[y] - Extract[yone, {i}])^2}, y],
  {i, step}];
ListPlot[Flatten[y /. s]]
y2 = Select[Flatten[y /. s], # < 0 &]
four = ListPlot[Thread[{xfour[y2], yfour[y2]}], PlotLabel → "position four",
  AspectRatio → Automatic, PlotStyle → RGBColor[0, 0, 0], PlotRange → {{-140, 50}, {-120, 80}}]
xxfour = N[xfour[N[y2]]];
yyfour = N[yfour[N[y2]]];
xfourpos = xfour[y2];
yfourpos = yfour[y2];

(*constant separation of left and right foot hinges*)
x20 = z2 - 1.8;
(*N[Mean[y2]];
N[Mean[x20]];
N[Mean[y2]] - N[Mean[x20]];*)

```

```

diff = separation + (N[Mean[y2]] - N[Mean[x20]]);
(*actual angular displacement between hinges 3 and five*)
x2 = x20 + diff;
(*2*Pi - (z2 - x2);
N[Mean[y2]] - N[Mean[x2]]; *)

(*position of hinge five*)
xfive[thetaone_] := xtwo + l * Cos[thetaone];
yfive[thetaone_] := ytwo + l * Sin[thetaone];
five = ListPlot[Thread[{xfive[x2], yfive[x2]}], PlotLabel -> "position five",
  AspectRatio -> Automatic, PlotStyle -> RGBColor[0, 0, 0], PlotRange -> {{-140, 50}, {-120, 80}}]
five2 = ListPlot[Thread[{xfive[x2], yfive[x2]}], PlotLabel -> "position five",
  AspectRatio -> Automatic, PlotStyle -> RGBColor[1, 0, 0], PlotRange -> {{-140, 50}, {-120, 80}}]
xxfive = N[xfive[N[x2]]];
yyfive = N[yfive[N[x2]]];
xfivepos = xfive[x2];
yfivepos = yfive[x2];

(*position of hinge eight*)
xeight = xtwo + m * Cos[z2 + 7 * Pi / 16]
yeight = ytwo + m * Sin[z2 + 7 * Pi / 16]
ListPlot[Thread[{xeight, yeight}]]
xeightpos = xeight;
yeightpos = yeight;

(*Show[three, five2, four]*)

(*position of foot*)
difx = Flatten[ParallelTable[Extract[xxfive, {i}] - Extract[xxfour, {i}], {i, step}]]
dify = Flatten[ParallelTable[Extract[yyfive, {i}] - Extract[yyfour, {i}], {i, step}]]
s := ParallelTable[
  Solve[{(m)^2 == (Extract[difx, {i}] + m * Cos[v])^2 + (Extract[dify, {i}] + m * Sin[v])^2}, v],
  {i, step}];
ListPlot[Flatten[v /. s]]
v2 = Select[Flatten[v /. s], # < 0 &]
v2o = Flatten[v2 /. s][[Flatten[ParallelTable[2 i, {i, step}]]]]
six = ListPlot[Thread[{xfive[x2] + m * Cos[v2o], yfive[x2] + m * Sin[v2o]}],
  PlotLabel -> "position six", AspectRatio -> Automatic,
  PlotStyle -> RGBColor[0, 0, 0], PlotRange -> {{-140, 50}, {-120, 80}}]
xsix = xfive[x2] + m * Cos[v2o]
ysix = yfive[x2] + m * Sin[v2o]
ListPlot[Thread[{phi, ysix}]]
v2oo = Flatten[v2 /. s][[Flatten[ParallelTable[2 i - 1, {i, step}]]]]
seven = ListPlot[Thread[{xfive[x2] + m * Cos[v2oo], yfive[x2] + m * Sin[v2oo]}],
  PlotLabel -> "position seven", AspectRatio -> Automatic,
  PlotStyle -> RGBColor[0, 0, 0], PlotRange -> {{-140, 50}, {-120, 80}}]
seven2 = ListPlot[Thread[{xfive[x2] + m * Cos[v2oo], yfive[x2] + m * Sin[v2oo]}],
  PlotLabel -> "position seven", AspectRatio -> Automatic, PlotStyle -> RGBColor[0, 0, 0]]
xseven = xfive[x2] + m * Cos[v2oo]
yseven = yfive[x2] + m * Sin[v2oo]
ListPlot[Thread[{phi, yseven}]]

```

```

xseven = xfive[x2] + m * Cos[v2oo];
(*xvseven=Flatten[{(1/2)*(-Extract[xseven,{-1}]+Extract[xseven,{2}]),
  ParallelTable[(1/2)*(-Extract[xseven,{i-1}]+Extract[xseven,{i+1}]),{i,2,step-1}],
  (1/2)*(-Extract[xseven,{step-1}]+Extract[xseven,{1}])}]
xaccseven=Flatten[{(1/2)*(-Extract[xvseven,{-1}]+Extract[xvseven,{2}]),
  ParallelTable[(1/2)*(-Extract[xvseven,{i-1}]+Extract[xvseven,{i+1}]),{i,2,step-1}],
  (1/2)*(-Extract[xvseven,{step-1}]+Extract[xvseven,{1}])}]*)

(*angular plots*)
ListPlot[Thread[{phi, z2}], PlotLabel -> "theta three", PlotStyle -> RGBColor[0, 0, 0]]
ListPlot[Thread[{phi, y2}], PlotLabel -> "theta four", PlotStyle -> RGBColor[1, 0, 0]]
ListPlot[Thread[{phi, x2}], PlotLabel -> "theta five", PlotStyle -> RGBColor[0, 0, 1]]

(*full linkage (one is extraneous solution, must plot both to check)*)
leg = ListLinePlot[{{Extract[xone, {example}], Extract[yone, {example}]},
  {xthree[Extract[z2, {example}]], ythree[Extract[z2, {example}]]},
  {xtwo, ytwo}, {xfour[Extract[y2, {example}]], yfour[Extract[y2, {example}]]},
  {Extract[xone, {example}], Extract[yone, {example}]},
  {{xthree[Extract[z2, {example}]], ythree[Extract[z2, {example}]]},
  {Extract[xeight, {example}], Extract[yeight, {example}]},
  {xfive[Extract[x2, {example}]], yfive[Extract[x2, {example}]]},
  {xtwo, ytwo}, {Extract[xeight, {example}], Extract[yeight, {example}]},
  {{xfive[Extract[x2, {example}]], yfive[Extract[x2, {example}]]},
  {xfive[Extract[x2, {example}]] + m * Cos[Extract[v2oo, {example}]],
  yfive[Extract[x2, {example}]] + m * Sin[Extract[v2oo, {example}]]},
  {xfour[Extract[y2, {example}]], yfour[Extract[y2, {example}]]}},
  PlotStyle -> RGBColor[0, 0, 0], AspectRatio -> Automatic,
  PlotRange -> {{-140, 50}, {-120, 80}},
  PlotLabel -> "Position of linkage during a complete locomotive cycle"]
leg2 = ListLinePlot[{{0, 0}, {Extract[xone, {example}], Extract[yone, {example}]},
  {xthree[Extract[z2, {example}]], ythree[Extract[z2, {example}]]},
  {xtwo, ytwo}, {xfour[Extract[y2, {example}]], yfour[Extract[y2, {example}]]},
  {Extract[xone, {example}], Extract[yone, {example}]},
  {{xthree[Extract[z2, {example}]], ythree[Extract[z2, {example}]]},
  {Extract[xeight, {example}], Extract[yeight, {example}]},
  {xfive[Extract[x2, {example}]], yfive[Extract[x2, {example}]]},
  {xtwo, ytwo}, {Extract[xeight, {example}], Extract[yeight, {example}]},
  {{xfive[Extract[x2, {example}]], yfive[Extract[x2, {example}]]},
  {xfive[Extract[x2, {example}]] + m * Cos[Extract[v2o, {example}]],
  yfive[Extract[x2, {example}]] + m * Sin[Extract[v2o, {example}]]},
  {xfour[Extract[y2, {example}]], yfour[Extract[y2, {example}]]}},
  PlotStyle -> RGBColor[0, 0, 0], AspectRatio -> Automatic,
  PlotRange -> {{-140, 50}, {-120, 80}},
  PlotLabel -> "Position of linkage during a complete locomotive cycle", Axes -> False]

(*plots of all hinge movement with and without leg*)
(*Show[four, five2]*)
Show[one, three, four, five, six, seven, leg]
Show[one, three, four, five, six, seven, leg2]
Show[one, three, four, five, seven]

```

```

six2 = ListPlot[Thread[{xfive[x2] + m * Cos[v2o], yfive[x2] + m * Sin[v2o]}],
  PlotLabel → "position six", AspectRatio → Automatic,
  PlotStyle → RGBColor[0, 0, 0], PlotRange → {{-140, 50}, {-120, 80}}];
seven2 = ListPlot[Thread[{xfive[x2] + m * Cos[v2oo], yfive[x2] + m * Sin[v2oo]}],
  PlotLabel → "position seven", AspectRatio → Automatic,
  PlotStyle → RGBColor[0, 0, 0], PlotRange → {{-140, 50}, {-120, 80}}];
(*locus plot*)
Show[six2, seven2]

(*y position of locus plot*)
yone1 = ListPlot[Thread[{phi, yfive[x2] + m * Sin[v2o]}],
  PlotStyle → RGBColor[0, 0, 0], PlotRange → {{0, 2 * Pi}, {-99, -75}}];
ytwo2 = ListPlot[Thread[{phi, yfive[x2] + m * Sin[v2oo]}],
  PlotStyle → RGBColor[0, 0, 0], PlotRange → {{0, 2 * Pi}, {-99, -75}}];
Show[yone1, ytwo2]

(*remove extraneous locus values for 24 time steps*)
xlocus24 =
  Flatten[{Extract[xseven, {1}], Flatten[ParallelTable[Extract[xsix, {i}], {i, 2, 13}]],
    Flatten[ParallelTable[Extract[xseven, {i}], {i, 14, 24}]]];
ylocus24 = Flatten[{Extract[yseven, {1}], Flatten[ParallelTable[Extract[ysix, {i}],
  {i, 2, 13}]], Flatten[ParallelTable[Extract[yseven, {i}], {i, 14, 24}]]];
ListPlot[Thread[{xlocus24, ylocus24}], AspectRatio → Automatic]

(*remove extraneous locus values for 48 time steps*)
xlocus48 =
  Flatten[{Extract[xseven, {1}], Flatten[ParallelTable[Extract[xsix, {i}], {i, 2, 25}]],
    Flatten[ParallelTable[Extract[xseven, {i}], {i, 26, 48}]]];
ylocus48 = Flatten[{Extract[yseven, {1}], Flatten[ParallelTable[Extract[ysix, {i}],
  {i, 2, 25}]], Flatten[ParallelTable[Extract[yseven, {i}], {i, 26, 48}]]];
ListPlot[Thread[{xlocus48, ylocus48}], AspectRatio → Automatic]

(*remove extraneous locus values for 96 time steps*)
xlocus96 = Flatten[
  {Extract[xseven, {{1}, {2}}], Flatten[ParallelTable[Extract[xsix, {i}], {i, 3, 49}]],
    Flatten[ParallelTable[Extract[xseven, {i}], {i, 50, 96}]]];
ylocus96 = Flatten[{Extract[yseven, {{1}, {2}}],
  Flatten[ParallelTable[Extract[ysix, {i}], {i, 3, 49}]],
    Flatten[ParallelTable[Extract[yseven, {i}], {i, 50, 96}]]];
ListPlot[Thread[{xlocus96, ylocus96}], PlotLabel → "support phase",
  PlotRange → {{-105, 0}, {-96, -90}}, PlotStyle → RGBColor[0, 0, 0]
(*plot x velocity and acceleration*)
xloc96vel =
  Flatten[{(1/2) * (-Extract[xlocus96, {-1}] + Extract[xlocus48, {2}]), ParallelTable[
    (1/2) * (-Extract[xlocus96, {i - 1}] + Extract[xlocus96, {i + 1}]), {i, 2, step - 1}],
    (1/2) * (-Extract[xlocus96, {step - 1}] + Extract[xlocus96, {1}])]; (*slope of xonepos*)
ListPlot[Thread[{phi, xloc96vel}], PlotStyle → RGBColor[0, 0, 0],
  PlotLabel → "x velocity of locus"]
xloc96acc = Flatten[{(1/2) * (-Extract[xloc96vel, {-1}] + Extract[xloc96vel, {2}]),
  ParallelTable[(1/2) * (-Extract[xloc96vel, {i - 1}] + Extract[xloc96vel, {i - step}]),
    {i, 2, step - 1}], (1/2) *

```

```

      (-Extract[xloc96vel, {step - 1}] + Extract[xloc96vel, {1}]]]; (*x velocity of locus*)
ListPlot[Thread[{phi, xloc96acc}], PlotStyle → RGBColor[0, 0, 0],
  PlotLabel → "x acceleration of locus"]

(*superimpose plot of leg over 24 time steps*)
multileg = ListLinePlot[Flatten[
  ParallelTable[{{Extract[xone, {i}], Extract[yone, {i}]}, {xthree[Extract[z2, {i}]],
    ythree[Extract[z2, {i}]]}, {xtwo, ytwo}, {xfour[Extract[y2, {i}]],
    yfour[Extract[y2, {i}]]}, {Extract[xone, {i}], Extract[yone, {i}]}}},
  {{xthree[Extract[z2, {i}]], ythree[Extract[z2, {i}]]}, {Extract[xeight, {i}],
    Extract[yeight, {i}]}, {xfive[Extract[x2, {i}]], yfive[Extract[x2, {i}]]},
  {xtwo, ytwo}, {Extract[xeight, {i}], Extract[yeight, {i}]}}},
  {{xfive[Extract[x2, {i}]], yfive[Extract[x2, {i}]]},
  {Extract[xlocus24, {i}], Extract[ylocus24, {i}]},
  {xfour[Extract[y2, {i}]], yfour[Extract[y2, {i}]]}}}, {i, step}], 1],
PlotStyle → RGBColor[0, 0, 0], AspectRatio → Automatic,
PlotRange → {{-140, 50}, {-120, 80}},
PlotLabel → "Position of linkage during a complete locomotive cycle"]

```

(*CRANK PAIR*)

```
(*reverse the order of the elements in each array to get pair to trace each
  path backwards, all x coordinates of pair have opposite sign as original leg*)
xonepair = -Reverse[xonepos];
xtwopair = -xtwopos;
xthreepair = -Reverse[xthreepos];
xfourpair = -Reverse[xfourpos];
xfivepair = -Reverse[xfivepos];
xsixpair = -Reverse[xsixpos];
xeightpair = -Reverse[xeightpos];
yonepair = Reverse[yonepos];
ytwopair = ytwopos;
ythreepair = Reverse[ythreepos];
yfourpair = Reverse[yfourpos];
yfivepair = Reverse[yfivepos];
ysixpair = Reverse[ysixpos];
yeightpair = Reverse[yeightpos];
positionoffootpair = ListPlot[Thread[{xsixpair, ysixpair}], PlotStyle -> RGBColor[0, 0, 0]];

leg3 = ListLinePlot[{{Extract[xone, {example}], Extract[yone, {example}]},
  {xthree[Extract[z2, {example}]], ythree[Extract[z2, {example}]]},
  {xtwo, ytwo}, {xfour[Extract[y2, {example}]], yfour[Extract[y2, {example}]]},
  {Extract[xone, {example}], Extract[yone, {example}]},
  {{xthree[Extract[z2, {example}]], ythree[Extract[z2, {example}]]},
  {Extract[xeight, {example}], Extract[yeight, {example}]},
  {xfive[Extract[x2, {example}]], yfive[Extract[x2, {example}]]},
  {xtwo, ytwo}, {Extract[xeight, {example}], Extract[yeight, {example}]},
  {{xfive[Extract[x2, {example}]], yfive[Extract[x2, {example}]]},
  {Extract[xsixpos, {example}], Extract[ysixpos, {example}]},
  {xfour[Extract[y2, {example}]], yfour[Extract[y2, {example}]]}},
  PlotStyle -> RGBColor[0, 0, 0], AspectRatio -> Automatic,
  PlotRange -> {{-140, 140}, {-120, 80}},
  PlotLabel -> "Position of linkage during a complete locomotive cycle"]
legpair = ListLinePlot[{{Extract[xonepair, {example - step / 2 - 2}],
  Extract[yonepair, {example - step / 2 - 2}]}, {Extract[xthreepair, {example - step / 2 - 2}],
  Extract[ythreepair, {example - step / 2 - 2}]}, {xtwopair, ytwopair},
  {Extract[xfourpair, {example - step / 2 - 2}], Extract[yfourpair, {example - step / 2 - 2}]},
  {Extract[xonepair, {example - step / 2 - 2}], Extract[yonepair, {example - step / 2 - 2}]},
  {{Extract[xthreepair, {example - step / 2 - 2}], Extract[ythreepair, {example - step / 2 - 2}]},
  {Extract[xeightpair, {example - step / 2 - 2}], Extract[yeightpair, {example - step / 2 - 2}]},
  {Extract[xfivepair, {example - step / 2 - 2}], Extract[yfivepair, {example - step / 2 - 2}]},
  {xtwopair, ytwopair}, {Extract[xeightpair, {example - step / 2 - 2}],
  Extract[yeightpair, {example - step / 2 - 2}]},
  {{Extract[xfivepair, {example - step / 2 - 2}], Extract[yfivepair, {example - step / 2 - 2}]},
  {Extract[xsixpair, {example - step / 2 - 2}], Extract[ysixpair, {example - step / 2 - 2}]},
  {Extract[xfourpair, {example - step / 2 - 2}], Extract[yfourpair, {example - step / 2 - 2}]},
  PlotStyle -> RGBColor[0, 0, 0], AspectRatio -> Automatic,
  PlotRange -> {{140, -140}, {-120, 80}},
  PlotLabel -> "Position of linkage during a complete locomotive cycle"]
(*plot a diagram of the linkage's pair for a given
time step specified by
"example," also introduce
a phase shift of 1/2*)
Show[leg3, legpair]
```

(*POSITION OF CM*)

```
(*position of crank cm*)
phi = Table[i, {i, 0, (2 Pi - 2 Pi / step), 2 Pi / step}];
xonecm = ParallelTable[a / 2 * Cos[Extract[phi, {i}]], {i, step}];
yonecm = ParallelTable[a / 2 * Sin[Extract[phi, {i}]], {i, step}];
cm1 = ListPlot[Thread[{xonecm, yonecm}],
  AspectRatio → Automatic, PlotRange → {{-140, 50}, {-120, 80}},
  PlotStyle → {RGBColor[0, 0, 1], PointSize[0.007]}, PlotLabel → "crank CM"];
one = ListLinePlot[Flatten[ParallelTable[{{0, 0}, {Extract[xone, {i}], Extract[yone, {i}]}},
  {i, step}], 1], AspectRatio → Automatic,
  PlotStyle → RGBColor[0, 0, 0], PlotRange → {{-140, 50}, {-120, 80}}];
CRANKCM = Show[cm1, one]
```

(*position of fixed hinge 2*)

```
xtwo = b * Cos[theta];
ytwo = b * Sin[theta];
```

(*cm of link 2,3*)

```
xthree[thetaone_] := xtwo + l * Cos[thetaone];
ythree[thetaone_] := ytwo + l * Sin[thetaone];
xthreecm[thetaone_] := xtwo + l / 2 * Cos[thetaone];
ythreecm[thetaone_] := ytwo + l / 2 * Sin[thetaone];
cm23 =
  ListPlot[Thread[{xthreecm[z2], ythreecm[z2]}], PlotLabel → "CM 23", AspectRatio → Automatic,
  PlotStyle → {RGBColor[0, 0, 1], PointSize[0.007]}, PlotRange → {{-140, 50}, {-120, 80}}];
twothree = ListLinePlot[Flatten[ParallelTable[
  {{xthree[Extract[z2, {i}]], ythree[Extract[z2, {i}]]}, {xtwo, ytwo}}, {i, step}], 1],
  AspectRatio → Automatic, PlotStyle → RGBColor[0, 0, 0],
  PlotRange → {{-140, 50}, {-120, 80}}];
CM23 = Show[cm23, twothree]
```

(*cm of link 1,3*)

```
xcm13 = Flatten[ParallelTable[{xthree[Extract[z2, {i}]] + Extract[xone, {i}]} / 2, {i, step}]]
ycm13 = Flatten[ParallelTable[{ythree[Extract[z2, {i}]] + Extract[yone, {i}]} / 2, {i, step}]]
cm13 = ListPlot[Thread[{xcm13, ycm13}], AspectRatio → Automatic,
  PlotStyle → {RGBColor[0, 0, 1], PointSize[0.007]}, PlotRange → {{-140, 50}, {-120, 80}}];
onethree = ListLinePlot[ParallelTable[{{xthree[Extract[z2, {i}]], ythree[Extract[z2, {i}]]},
  {Extract[xone, {i}], Extract[yone, {i}]}}, {i, step}], AspectRatio → Automatic,
  PlotStyle → RGBColor[0, 0, 0], PlotRange → {{-140, 50}, {-120, 80}}, PlotLabel → "CM 13"];
CM13 = Show[cm13, onethree]
```

(*cm of link 2,4*)

```

xfour[thetaone_] := xtwo + 1 * Cos[thetaone];
yfour[thetaone_] := ytwo + 1 * Sin[thetaone];
xfourcm[thetaone_] := xtwo + 1 / 2 * Cos[thetaone];
yfourcm[thetaone_] := ytwo + 1 / 2 * Sin[thetaone];
cm24 = ListPlot[Thread[{xfourcm[y2], yfourcm[y2]}],
  PlotLabel -> "position four", AspectRatio -> Automatic,
  PlotStyle -> {RGBColor[0, 0, 1], PointSize[0.007]}, PlotRange -> {{-140, 50}, {-120, 80}}];
twofour = ListLinePlot[ParallelTable[{xfour[Extract[y2, {i}]], yfour[Extract[y2, {i}]]},
  {xtwo, ytwo}}, {i, step}], PlotLabel -> "CM 24", AspectRatio -> Automatic,
  PlotStyle -> RGBColor[0, 0, 0], PlotRange -> {{-140, 50}, {-120, 80}}];
CM24 = Show[cm24, twofour]

(*cm of link 1,4*)
xcm14 = Flatten[ParallelTable[{xfour[Extract[y2, {i}]] + Extract[xone, {i}]] / 2, {i, step}]]
ycm14 = Flatten[ParallelTable[{yfour[Extract[y2, {i}]] + Extract[yone, {i}]] / 2, {i, step}]]
cm14 = ListPlot[Thread[{xcm14, ycm14}], AspectRatio -> Automatic,
  PlotStyle -> {RGBColor[0, 0, 1], PointSize[0.007]}, PlotRange -> {{-140, 50}, {-120, 80}}];
onefour = ListLinePlot[ParallelTable[{xfour[Extract[y2, {i}]], yfour[Extract[y2, {i}]]},
  {Extract[xone, {i}], Extract[yone, {i}]}], {i, step}], AspectRatio -> Automatic,
  PlotStyle -> RGBColor[0, 0, 0], PlotLabel -> "CM 14", PlotRange -> {{-140, 50}, {-120, 80}}];
CM14 = Show[cm14, onefour]

(*cm of link 2,5*)
xfive[thetaone_] := xtwo + 1 * Cos[thetaone];
yfive[thetaone_] := ytwo + 1 * Sin[thetaone];
xfivecm[thetaone_] := xtwo + 1 / 2 * Cos[thetaone];
yfivecm[thetaone_] := ytwo + 1 / 2 * Sin[thetaone];
cm25 = ListPlot[Thread[{xfivecm[x2], yfivecm[x2]}],
  PlotLabel -> "position five", AspectRatio -> Automatic,
  PlotStyle -> {RGBColor[0, 0, 1], PointSize[0.007]}, PlotRange -> {{-140, 50}, {-120, 80}}];
twofive = ListLinePlot[ParallelTable[{xfive[Extract[x2, {i}]], yfive[Extract[x2, {i}]]},
  {xtwo, ytwo}}, {i, step}], PlotLabel -> "CM 25", AspectRatio -> Automatic,
  PlotStyle -> RGBColor[0, 0, 0], PlotRange -> {{-140, 50}, {-120, 80}}];
CM25 = Show[cm25, twofive]

(*cm of link 2,8*)
xeight = xtwo + m * Cos[z2 + 7 * Pi / 16];
yeight = ytwo + m * Sin[z2 + 7 * Pi / 16];
xeightcm = xtwo + m / 2 * Cos[z2 + 7 * Pi / 16];
yeightcm = ytwo + m / 2 * Sin[z2 + 7 * Pi / 16];
cm28 = ListPlot[Thread[{xeightcm, yeightcm}],
  PlotLabel -> "position eight", AspectRatio -> Automatic,
  PlotStyle -> {RGBColor[0, 0, 1], PointSize[0.007]}, PlotRange -> {{-140, 50}, {-120, 80}}];
twoeight = ListLinePlot[ParallelTable[{Extract[xeight, {i}], Extract[yeight, {i}]}],
  {xtwo, ytwo}}, {i, step}], PlotLabel -> "CM28", AspectRatio -> Automatic,
  PlotStyle -> RGBColor[0, 0, 0], PlotRange -> {{-140, 50}, {-120, 80}}];
CM28 = Show[cm28, twoeight]

```

```
(*cm of link 8,3*)
xcm83 =
  Flatten[ParallelTable[{xthree[Extract[z2, {i}]] + Extract[xeight, {i}]} / 2, {i, step}]]
ycm83 = Flatten[ParallelTable[{ythree[Extract[z2, {i}]] + Extract[yeight, {i}]} / 2, {i, step}]]
cm83 = ListPlot[Thread[{xcm83, ycm83}], AspectRatio → Automatic,
  PlotStyle → {RGBColor[0, 0, 1], PointSize[0.007]}, PlotRange → {{-140, 50}, {-120, 80}}];
eightthree = ListLinePlot[ParallelTable[{{xthree[Extract[z2, {i}]], ythree[Extract[z2, {i}]]},
  {Extract[xeight, {i}], Extract[yeight, {i}]}}, {i, step}], AspectRatio → Automatic,
  PlotStyle → RGBColor[0, 0, 0], PlotLabel → "CM 83", PlotRange → {{-140, 50}, {-120, 80}}];
CM83 = Show[cm83, eightthree]
```

```
(*cm of link 8,5*)
xcm85 = Flatten[ParallelTable[{xfive[Extract[x2, {i}]] + Extract[xeight, {i}]} / 2, {i, step}]]
ycm85 = Flatten[ParallelTable[{yfive[Extract[x2, {i}]] + Extract[yeight, {i}]} / 2, {i, step}]]
cm85 = ListPlot[Thread[{xcm85, ycm85}], AspectRatio → Automatic,
  PlotStyle → {RGBColor[0, 0, 1], PointSize[0.007]}, PlotRange → {{-140, 50}, {-120, 80}}];
eightfive = ListLinePlot[ParallelTable[{{xfive[Extract[x2, {i}]], yfive[Extract[x2, {i}]]},
  {Extract[xeight, {i}], Extract[yeight, {i}]}}, {i, step}], AspectRatio → Automatic,
  PlotStyle → RGBColor[0, 0, 0], PlotLabel → "CM 85", PlotRange → {{-140, 50}, {-120, 80}}];
CM85 = Show[cm85, eightfive]
```

```
(*cm of link between foot and hinge five*)
xcm75 =
  Flatten[ParallelTable[{xfive[Extract[x2, {i}]] + Extract[xlocus48, {i}]} / 2, {i, step}]]
ycm75 = Flatten[ParallelTable[
  {yfive[Extract[x2, {i}]] + Extract[ylocus48, {i}]} / 2, {i, step}]]
cm75 = ListPlot[Thread[{xcm75, ycm75}], AspectRatio → Automatic,
  PlotStyle → {RGBColor[0, 0, 1], PointSize[0.007]}, PlotRange → {{-140, 50}, {-120, 80}}];
sevenfive = ListLinePlot[ParallelTable[{{xfive[Extract[x2, {i}]], yfive[Extract[x2, {i}]]},
  {Extract[xlocus48, {i}], Extract[ylocus48, {i}]}}, {i, step}], AspectRatio → Automatic,
  PlotStyle → RGBColor[0, 0, 0], PlotLabel → "CM 75", PlotRange → {{-140, 50}, {-120, 80}}];
CM75 = Show[cm75, sevenfive]
```

```
(*cm of link between foot and hinge four*)
xcm74 =
  Flatten[ParallelTable[{xfour[Extract[y2, {i}]] + Extract[xlocus48, {i}]} / 2, {i, step}]]
ycm74 = Flatten[ParallelTable[
  {yfour[Extract[y2, {i}]] + Extract[ylocus48, {i}]} / 2, {i, step}]]
cm74 = ListPlot[Thread[{xcm74, ycm74}], AspectRatio → Automatic,
  PlotStyle → {RGBColor[0, 0, 1], PointSize[0.007]}, PlotRange → {{-140, 50}, {-120, 80}}];
sevenfour = ListLinePlot[ParallelTable[{{xfour[Extract[y2, {i}]], yfour[Extract[y2, {i}]]},
  {Extract[xlocus48, {i}], Extract[ylocus48, {i}]}}, {i, step}], AspectRatio → Automatic,
  PlotLabel → "CM 74", PlotStyle → RGBColor[0, 0, 0], PlotRange → {{-140, 50}, {-120, 80}}];
CM74 = Show[cm74, sevenfour]
```

```
(*plot all cm plots together*)
Show[CRANKCM, CM13, CM14, CM23, CM24, CM83, CM28, CM85, CM25, CM74, CM75]
```

```
(*caluclate total cm and plot*)
```

```

Sqrt[(Extract[xeight, {1}] - xthree[Extract[z2, {1}]])^2 +
      (Extract[yeight, {1}] - ythree[Extract[z2, {1}]])^2]
xtotcm = (a * xonecm + b * xcml3 + b * xcml4 + l * xthreecm[z2] + 1 * xfourcm[y2] +
          Sqrt[(Extract[xeight, {1}] - xthree[Extract[z2, {1}]])^2 +
              (Extract[yeight, {1}] - ythree[Extract[z2, {1}]])^2] * xcm83 +
          m * xeightcm + Sqrt[(Extract[xeight, {1}] - xthree[Extract[z2, {1}]])^2 +
              (Extract[yeight, {1}] - ythree[Extract[z2, {1}]])^2] * xcm85 + 1 * xfivecm[x2] + m * xcm74 +
          m * xcm75) / (a + b + b + l + l + Sqrt[(Extract[xeight, {1}] - xthree[Extract[z2, {1}]])^2 +
              (Extract[yeight, {1}] - ythree[Extract[z2, {1}]])^2] +
          m + Sqrt[(Extract[xeight, {1}] - xthree[Extract[z2, {1}]])^2 +
              (Extract[yeight, {1}] - ythree[Extract[z2, {1}]])^2] + 1 + m + m)
ytotcm = (a * yonecm + b * ycml3 + b * ycml4 + l * ythreecm[z2] + 1 * yfourcm[y2] +
          Sqrt[(Extract[xeight, {1}] - xthree[Extract[z2, {1}]])^2 +
              (Extract[yeight, {1}] - ythree[Extract[z2, {1}]])^2] * ycm83 +
          m * yeightcm + Sqrt[(Extract[xeight, {1}] - xthree[Extract[z2, {1}]])^2 +
              (Extract[yeight, {1}] - ythree[Extract[z2, {1}]])^2] * ycm85 + 1 * yfivecm[x2] + m * ycm74 +
          m * ycm75) / (a + b + b + l + l + Sqrt[(Extract[xeight, {1}] - xthree[Extract[z2, {1}]])^2 +
              (Extract[yeight, {1}] - ythree[Extract[z2, {1}]])^2] +
          m + Sqrt[(Extract[xeight, {1}] - xthree[Extract[z2, {1}]])^2 +
              (Extract[yeight, {1}] - ythree[Extract[z2, {1}]])^2] + 1 + m + m)
TOT = ListPlot[Thread[{xtotcm, ytotcm}], AspectRatio -> Automatic,
               PlotStyle -> {RGBColor[0, 0, 1], PointSize[0.007]}, PlotRange -> {{-140, 50}, {-120, 80}}];
Show[multileg, TOT]
Max[xtotcm] - Min[xtotcm]
Max[ytotcm] - Min[ytotcm]

```

(*CM OF PAIR*)

```

(*x cm manipulation*)
Partition[xtotcm, step / 2];
revcmx = Flatten[Reverse[Partition[xtotcm, step / 2], 2]];
revcmx2 = Insert[revcmx, Extract[revcmx, {step}], 1];
pcmx = Delete[revcmx2, step + 1]; (*the last four lines rearrange the original
matrix so that it describes the leg pair and is reused throughout this section*)
ListPlot[xtotcm]; (*plot the x position of cm of leg 1*)
ListPlot[-pcmx]; (*plot the x position of cm of leg 2*)
ListPlot[Thread[{phi, (xtotcm - pcmx) / 2}], PlotStyle -> RGBColor[0, 0, 0],
PlotLabel -> "x position of leg pair total cm"] (*plot the total x cm for both legs*)
Max[(xtotcm - pcmx) / 2] - Min[(xtotcm - pcmx) / 2]

(*the y cm manipulation follows directly from the x*)
Partition[ytotcm, step / 2];
revcmx = Flatten[Reverse[Partition[ytotcm, step / 2], 2]];
revcmx2 = Insert[revcmx, Extract[revcmx, {step}], 1];
pcmy = Delete[revcmx2, step + 1];
ListPlot[ytotcm];
ListPlot[pcmy];
ListPlot[Thread[{phi, (ytotcm + pcmy) / 2}], PlotStyle -> RGBColor[0, 0, 0],
PlotLabel -> "y position of leg pair total cm"] (*plot the total y cm for both legs*)
Max[(ytotcm - pcmy) / 2] - Min[(ytotcm - pcmy) / 2]

cm = ListPlot[Thread[{xtotcm, ytotcm}], PlotStyle -> RGBColor[0, 0, 0]]; (*plot cm of leg 1*)
pcm = ListPlot[Thread[{-pcmx, pcmy}], PlotStyle -> RGBColor[0, 0, 0]]; (*plot cm of leg 2*)
totcm = ListPlot[Thread[{(xtotcm - pcmx) / 2, (ytotcm + pcmy) / 2}], PlotStyle -> RGBColor[0, 0, 1]]
(*plot total cm of leg pair*)
Show[leg3, legpair, totcm, cm, pcm,
AspectRatio -> Automatic, PlotRange -> {{-140, 140}, {-120, 80}}]
(*show three previous plots together with pair of legs at time "example"*)
Show[ListLinePlot[ParallelTable[{{Extract[xtotcm, {i}], Extract[ytotcm, {i}]},
{-Extract[pcmx, {i}], Extract[pcmy, {i}]}], {i, step}], PlotStyle -> RGBColor[0, 0, 0]],
totcm] (*check that the total cm plots lie at the center of the
line connecting cm to cm pair*)

```

(*TOTAL CM OF THREE PAIRS OF LEGS OFFSET BY 120 DEGREES*)

```

cmxpart = Partition[(xtotcm - pcmx) / 2, step / 3];
(*manipulate original cmx to crate phase shifted arrays*)
cmxphase = Delete[Insert[cmxpart, Extract[cmxpart, {3}], 1], 4];
cmxphase2 = Delete[Insert[cmxphase, Extract[cmxphase, {3}], 1], 4];
cmxphase0 = Flatten[cmxphase]; (*120 degree phase shift*)
cmxphase20 = Flatten[cmxphase2]; (*240 degree phase shift*)
cmxphasefinal = ((xtotcm - pcmx) / 2 + cmxphase0 + cmxphase20) / 3; (*total cm of three pairs*)
Show[ListPlot[Thread[{phi, (xtotcm - pcmx) / 2}], PlotStyle -> RGBColor[0, 0, 0]],
  ListPlot[Thread[{phi, cmxphase0}], PlotStyle -> RGBColor[0, 0, 0]],
  ListPlot[Thread[{phi, cmxphase20}], PlotStyle -> RGBColor[0, 0, 0]],
  ListPlot[Thread[{phi, cmxphasefinal}], PlotStyle -> RGBColor[0, 0, 1]],
  PlotLabel -> "x position of 120 degree phased legs"] (*plot all four*)
Max[cmxphasefinal] - Min[cmxphasefinal]

cmypart = Partition[(ytotcm + pcmy) / 2, step / 3];
(*manipulate original cmy to crate phase shifted arrays*)
cmypphase = Delete[Insert[cmypart, Extract[cmypart, {3}], 1], 4];
cmypphase2 = Delete[Insert[cmypphase, Extract[cmypphase, {3}], 1], 4];
cmypphase0 = Flatten[cmypphase]; (*120 degree phase shift*)
cmypphase20 = Flatten[cmypphase2]; (*240 degree phase shift*)
cmypphasefinal = ((ytotcm + pcmy) / 2 + cmypphase0 + cmypphase20) / 3; (*total cm of three pairs*)
Show[ListPlot[Thread[{phi, (ytotcm + pcmy) / 2}], PlotStyle -> RGBColor[0, 0, 0]],
  ListPlot[Thread[{phi, cmypphase0}], PlotStyle -> RGBColor[0, 0, 0]],
  ListPlot[Thread[{phi, cmypphase20}], PlotStyle -> RGBColor[0, 0, 0]],
  ListPlot[Thread[{phi, cmypphasefinal}], PlotStyle -> RGBColor[0, 0, 1]],
  PlotLabel -> "y position of 120 degree phased legs"] (*plot all four*)
Max[cmypphasefinal] - Min[cmypphasefinal]

ListPlot[Thread[{cmxphasefinal, cmypphasefinal}], AspectRatio -> Automatic] (*plot position*)
Show[leg, legpair, ListPlot[Thread[{cmxphasefinal, cmypphasefinal}],
  cm, pcm, AspectRatio -> Automatic, PlotRange -> {{-140, 140}, {-120, 80}}]
  (*plot position of cm with legs and individual cms of legs*)

```

Appendix B: Theo Jansen Analysis

This appendix contains more detailed analysis of the position, velocity, and acceleration of the hinges and center of mass for the Theo Jansen mechanism.

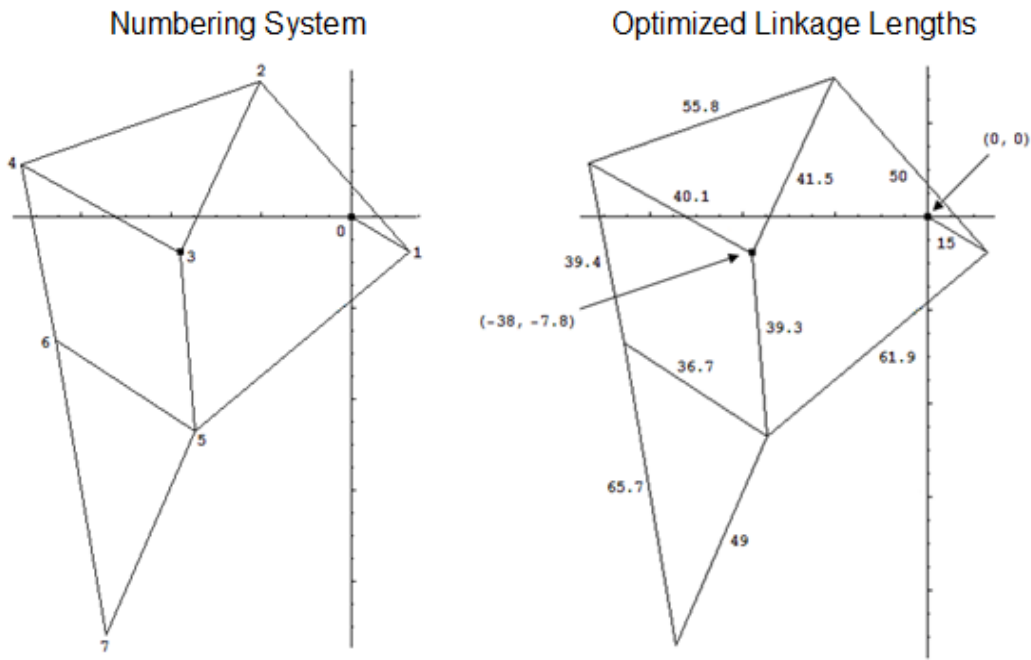

Figure 3.3.1: Diagram of Theo Jansen mechanism showing numbering system and optimized linkage lengths. In this paper hinge 1 may be called “the crank” and hinge seven may be called “the foot.” Hinges 0 and 3 have fixed positions relative to each other for the entire locomotive cycle; the convention in this analysis will be fix hinge 0 at the origin and hinge 3 at (-38,-7.8).

Figures B1, B2, B3, B4, B5, B6, and B7 show the position, velocity, and acceleration of each of these hinges during a complete locomotive cycle with magnitude as the vertical axis and time as the horizontal axis. Since I have picked an arbitrary coordinate system to plot this linkage, the exact values of position, velocity, and acceleration in these plots are not meaningful, though their relative magnitudes are. The scale of the time axis is meaningless because it is a product of the number of time steps I used to divide the length of one locomotive cycle (ie it spans 1 through 48 in figures B1-7).

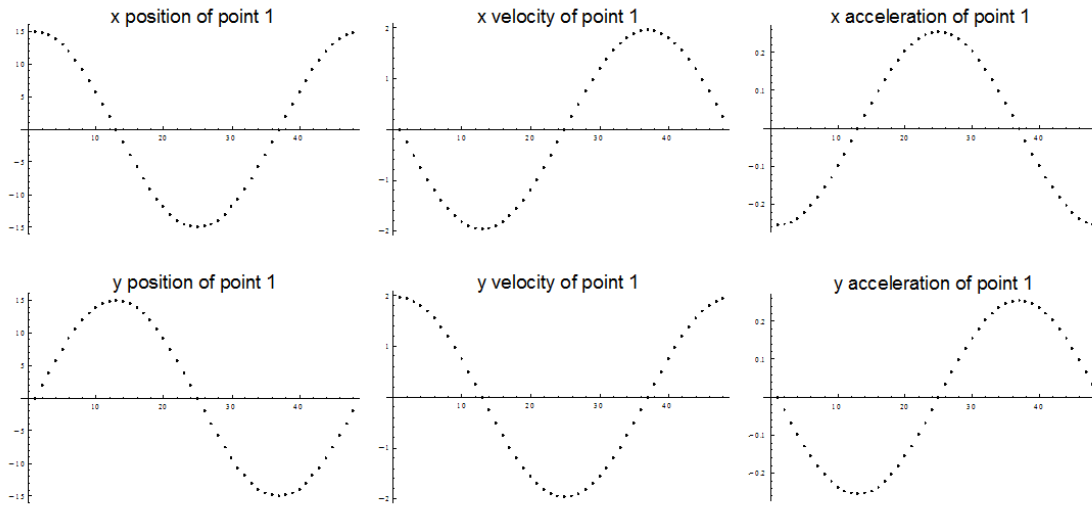

Figure B1: x and y position, velocity, and acceleration plots of point one (crank). Vertical axis is distance, distance per time, and distance per time squared, respectively. Horizontal axis is time.

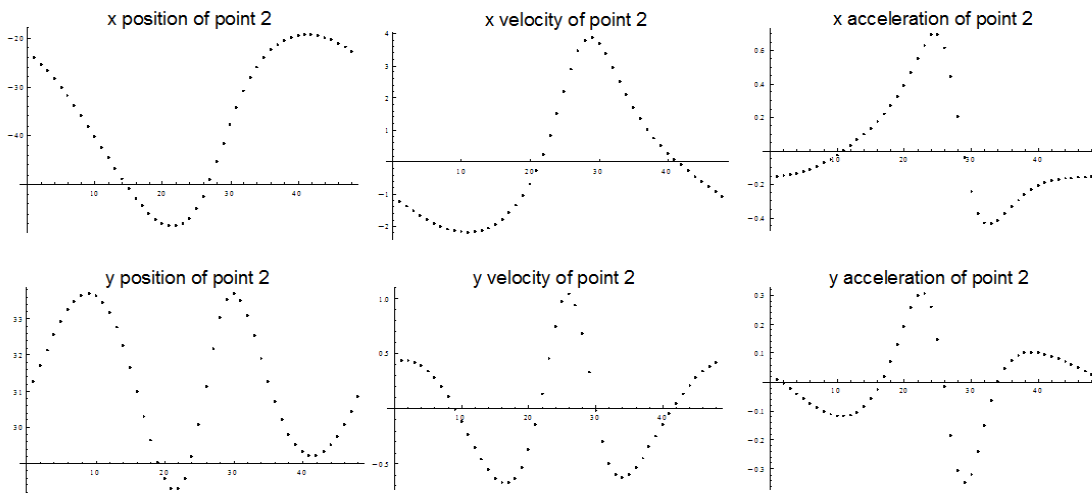

Figure B2: x and y position, velocity, and acceleration plots of point two.

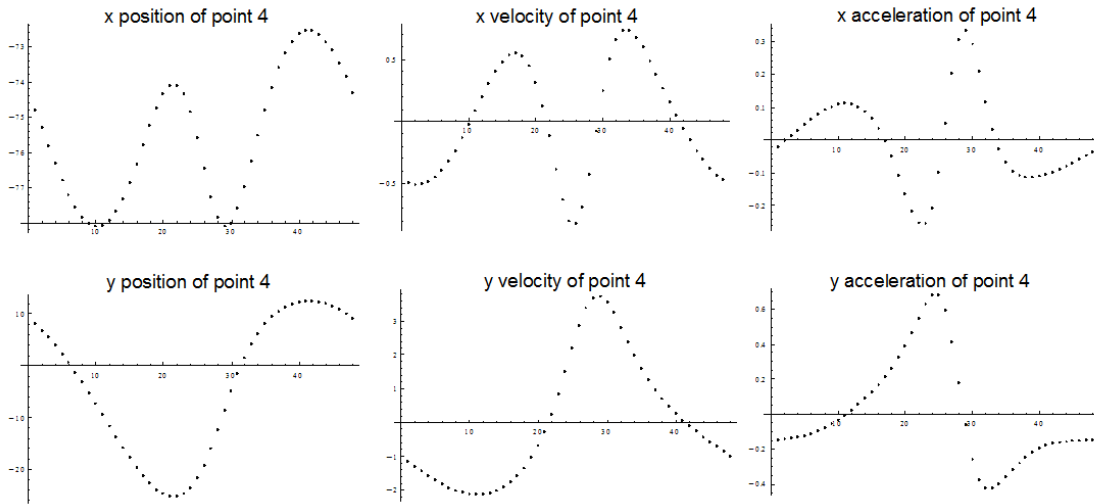

Figure B3: x and y position, velocity, and acceleration plots of point four.

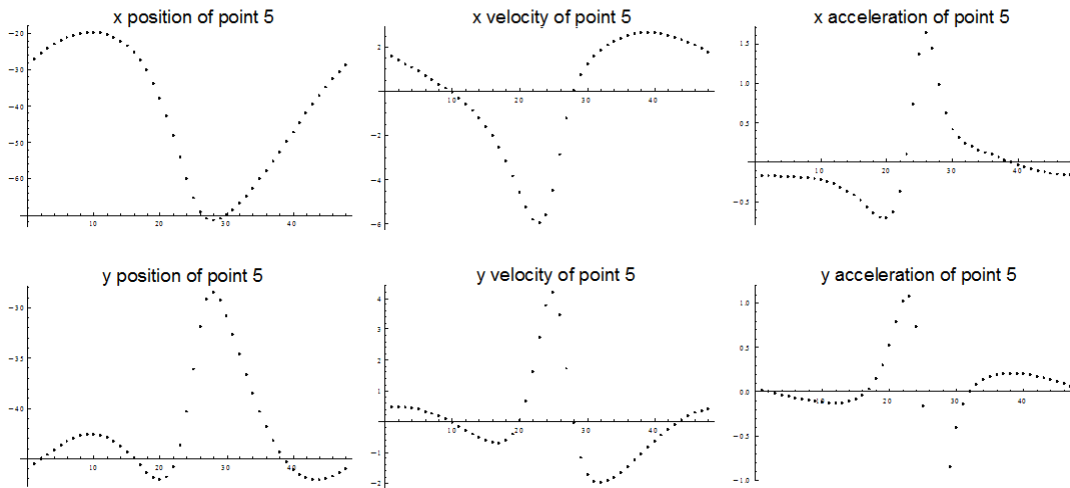

Figure B4: x and y position, velocity, and acceleration plots of point five.

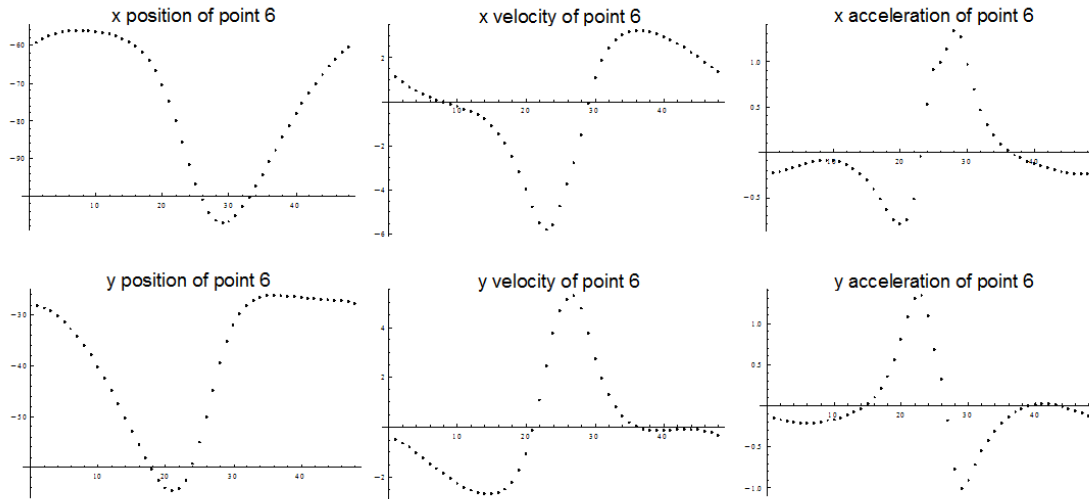

Figure B5: x and y position, velocity, and acceleration plots of point six.

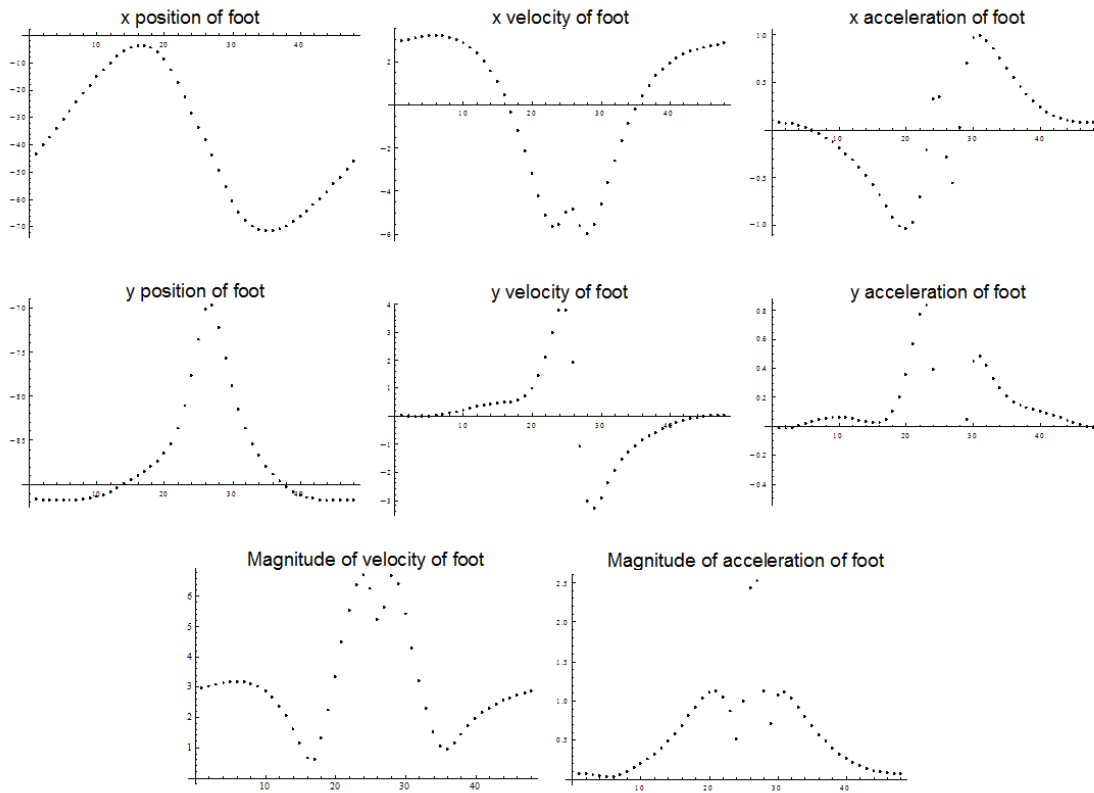

Figure B7: x and y position, velocity, and acceleration plots of point seven (the foot).

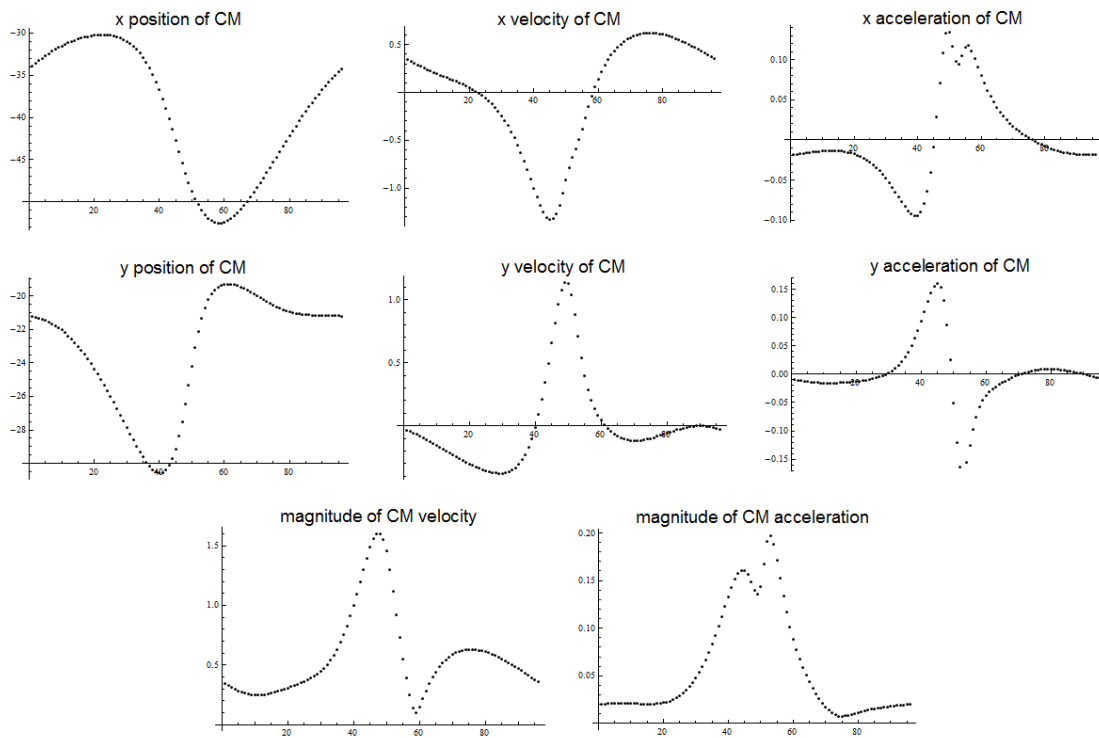

Figure B8: x and y position, velocity, and acceleration of total center of mass of one leg of Theo Jansen mechanism for one complete locomotive cycle.

Appendix C: Optimization of Four Bar Linkage #1 Plots

This appendix contains a sample of the plots I generated during the optimization of four bar linkage #1 in order to understand how the length of each part of the linkage affected the overall movement. Numbering and naming systems are given below and a summary table of my findings is given on the next page.

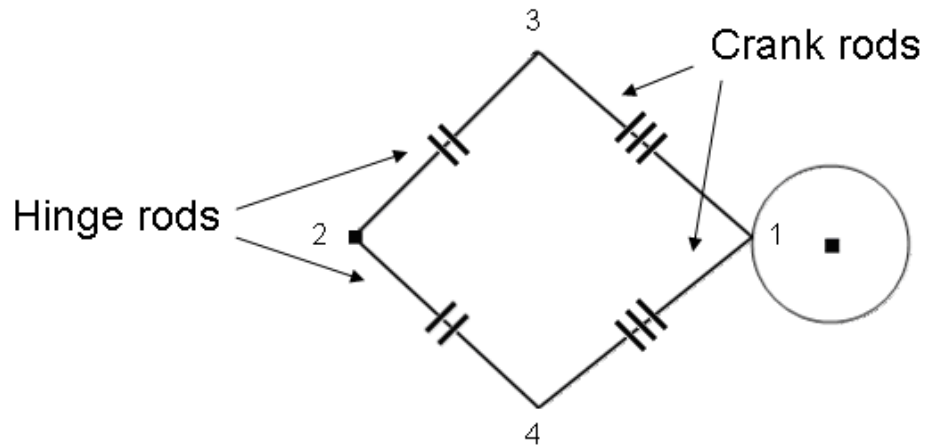

Figure 5.3.1: Numbering system of four bar linkage with “hinge rods” and “crank rods” labeled. Symmetry indicated with hash marks.

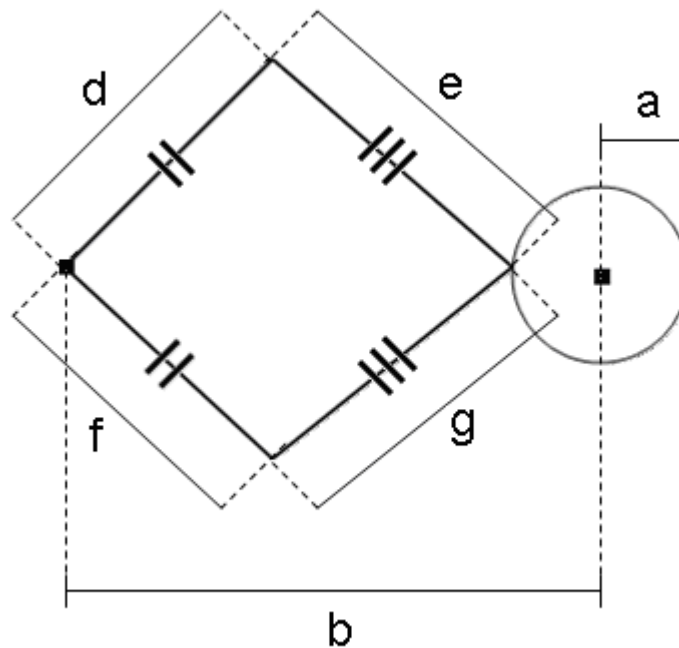

Figure 5.3.2: Naming system of lengths of rigid bodies in four bar linkage. For this portion of the optimization, the fixed points have no y displacement between them.

Table 5.3.1: Summary of results from four bar linkage #1 optimization

Parameter	Improves relative turning points of hinges three and four	Increases speed of “fast” portion of cycle
Length of hinge rod	Long hinge rod	Long hinge rod
Distance of fixed hinge from crank axis	Hinge close to crank	Hinge close to crank
Radius of crank	Large crank	Large crank
Radius of crank (constant distance between edge of crank path and fixed hinge 2)	Large crank	Large crank
Crank rod length	Short crank rod	Little effect
70:50 ratio of rods	Long hinge rod	Long hinge rod
30:50 ratio of rods	Long hinge rod	Long hinge rod
70:50 and 50:30 ratios	70:50	70:50
Overall length of rods	Little effect	Long rods

Comparison of hinge rod length

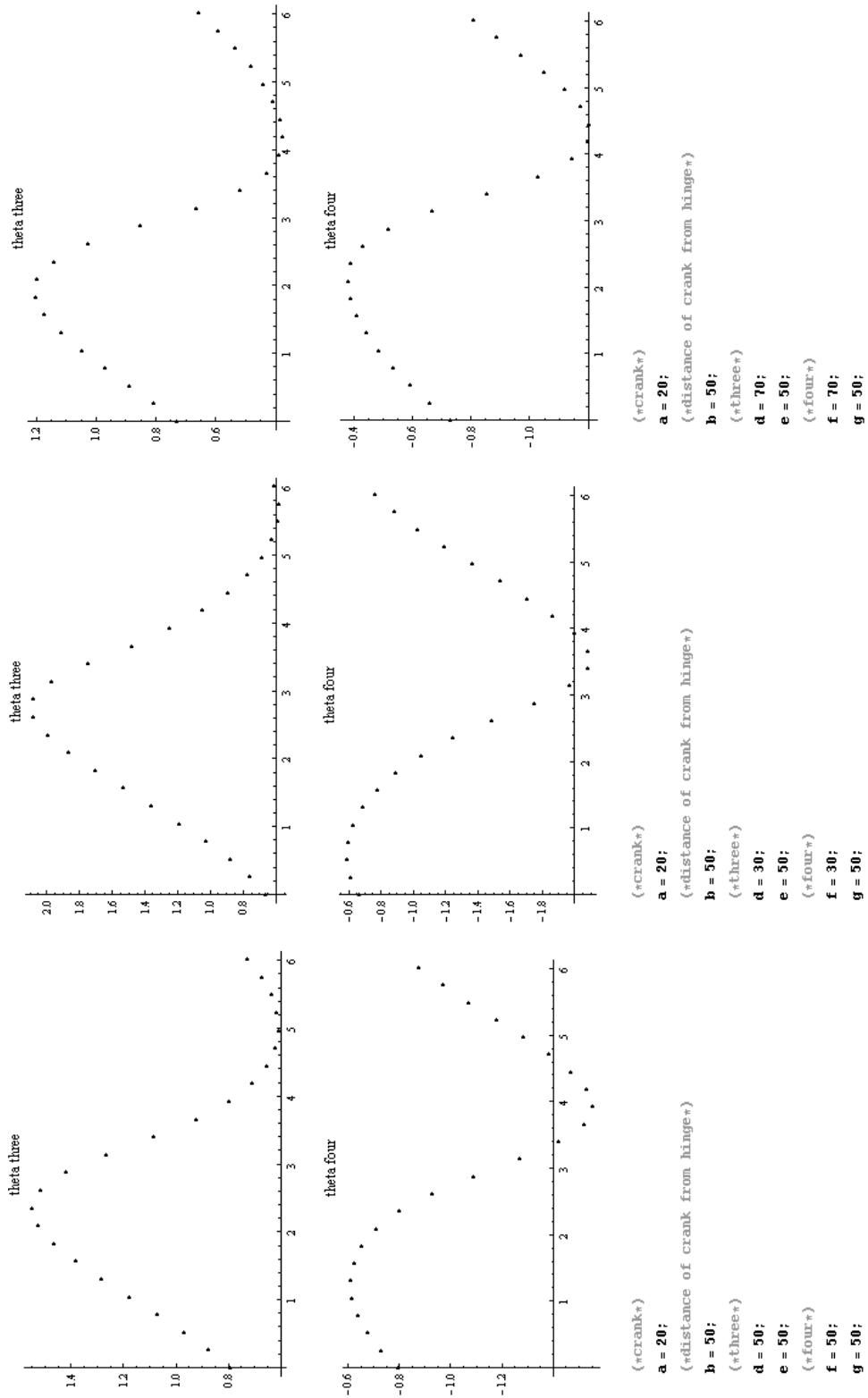

Figure C1: Length of hinge rod varied and resulting angular movement plotted.

Comparison of crank shaft length

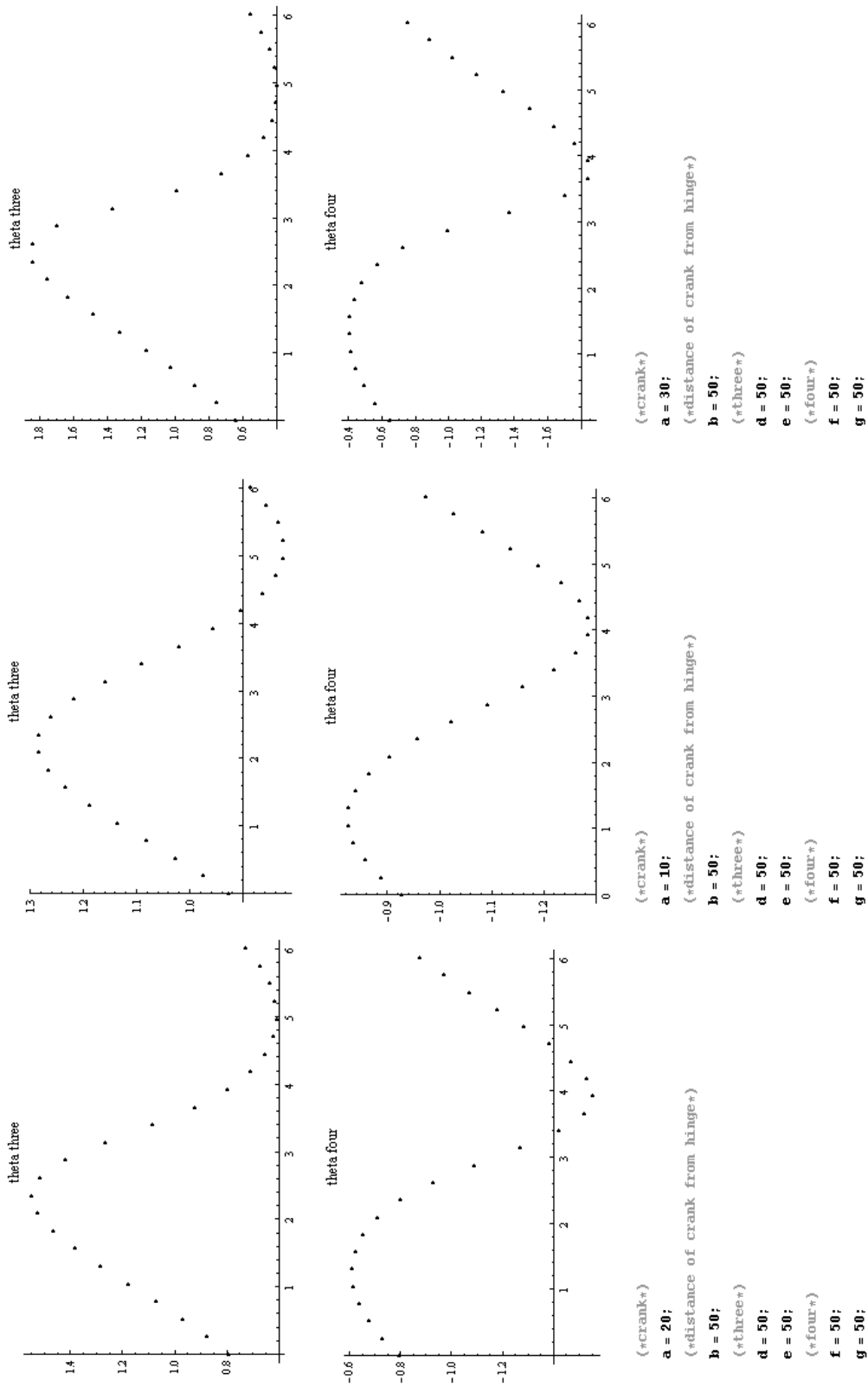

Figure C2: Length of crank shaft varied and resulting angular movement plotted.

Comparison of crank shaft length with constant distance between edge of crank circumference and fixed hinge

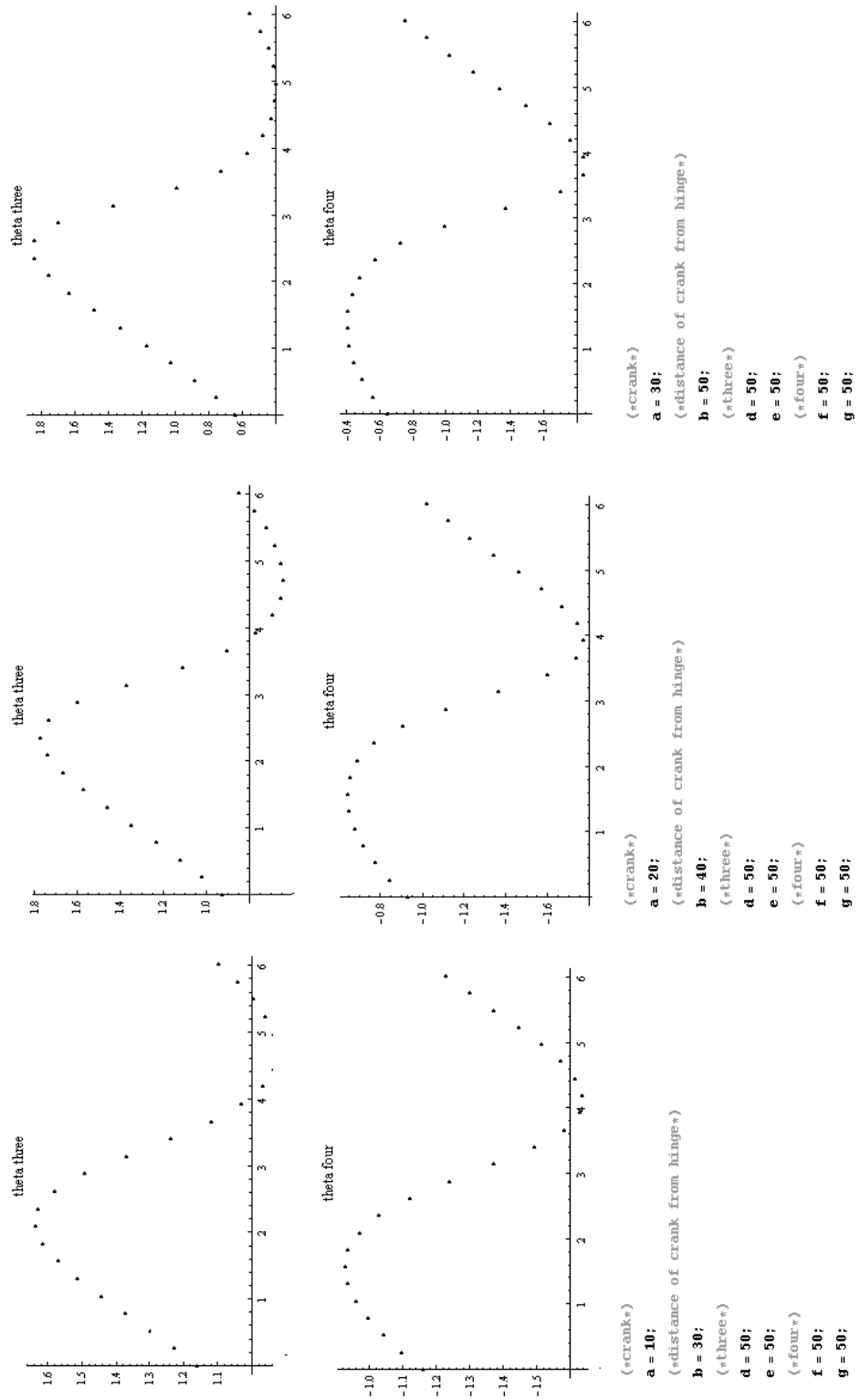

Figure C3: Length of crank shaft and position of fixed hinge varied and resulting angular movement plotted.

Comparison of distance of crank from fixed hinge

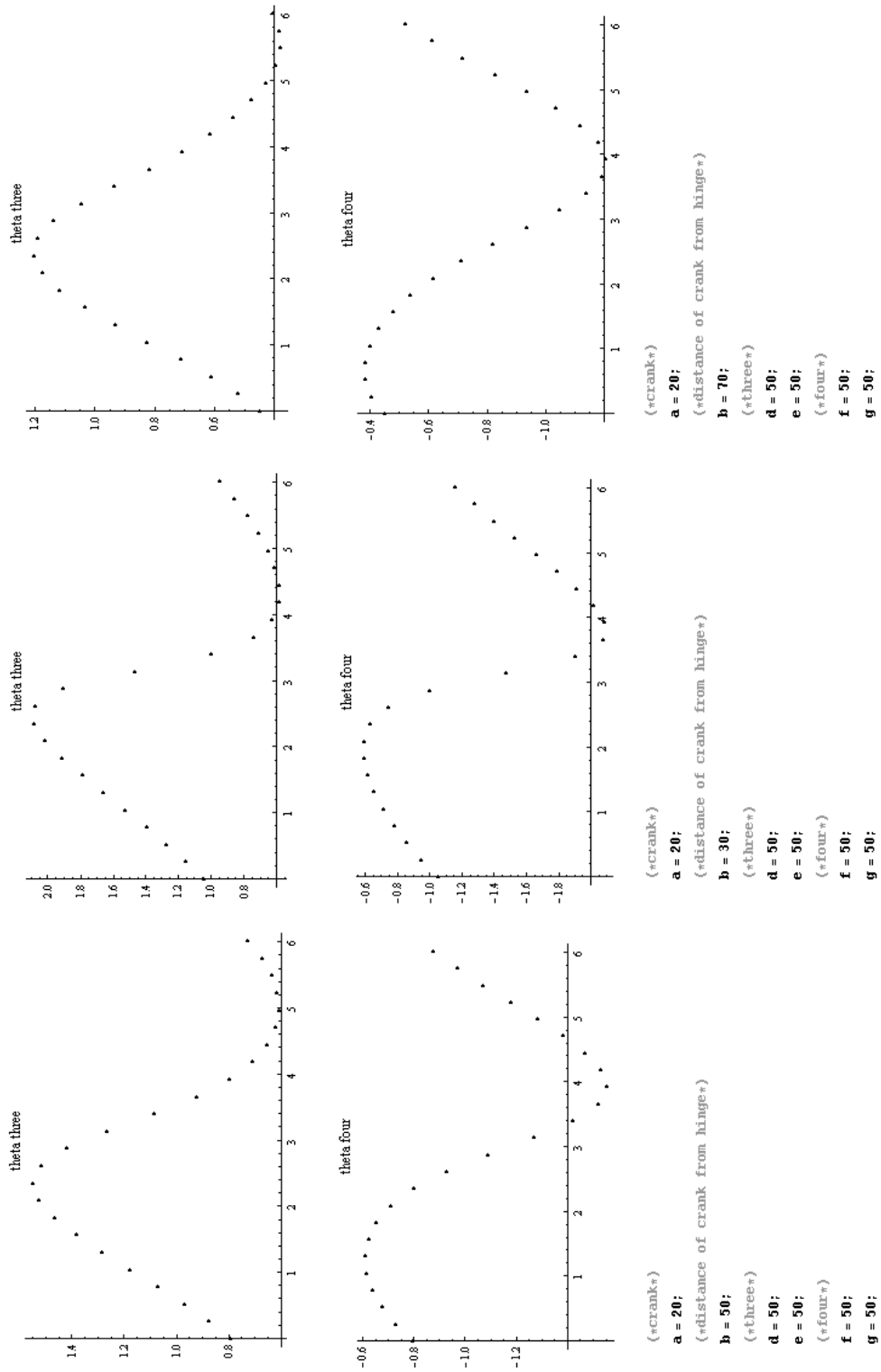

Figure C4: Distance of fixed hinge from crank varied and resulting angular movement plotted.

Comparison of crank rod lengths

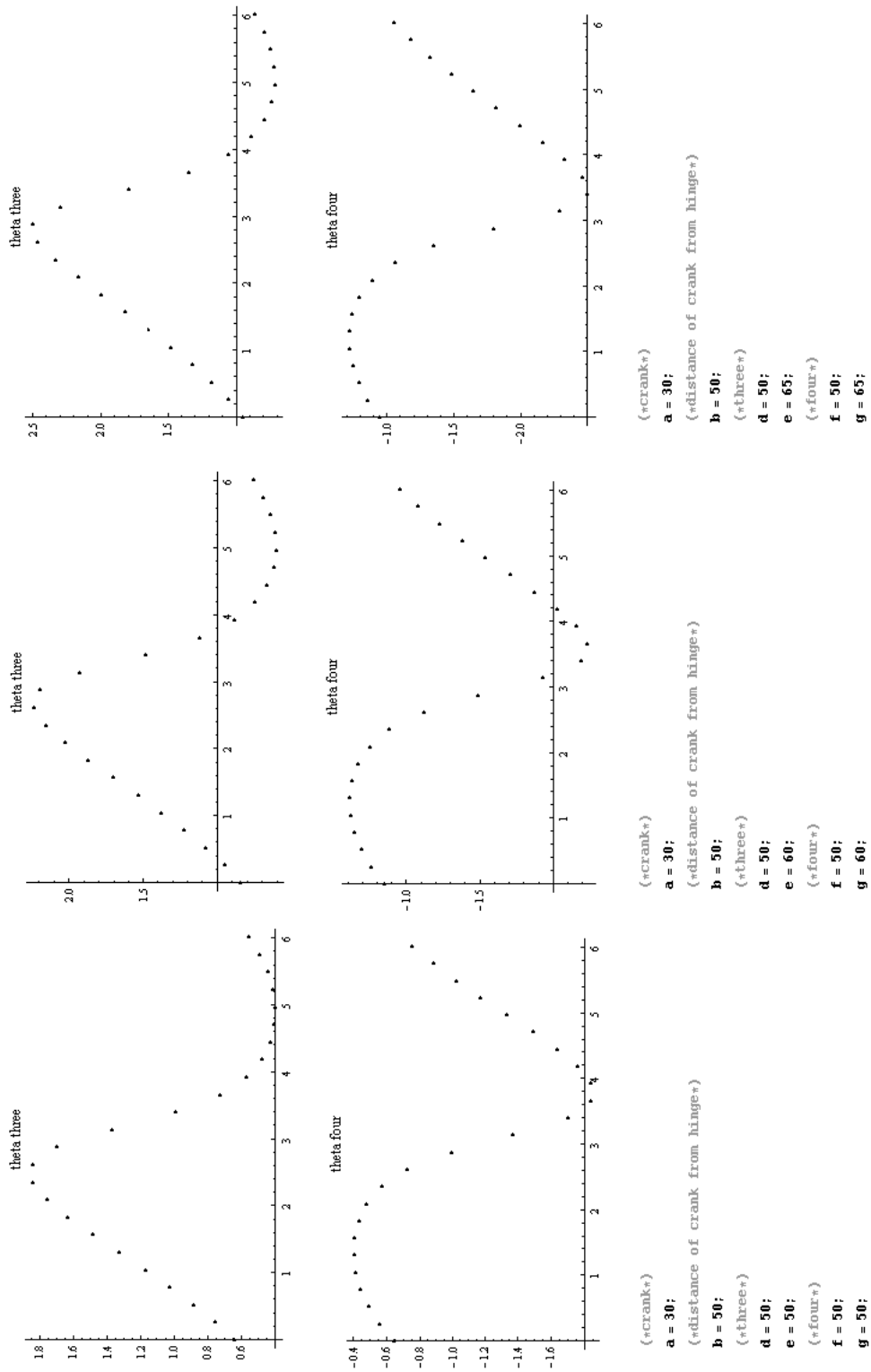

Figure C5: Length of crank rod varied and resulting angular movement plotted.

Comparison of 70:50 ratio of rods

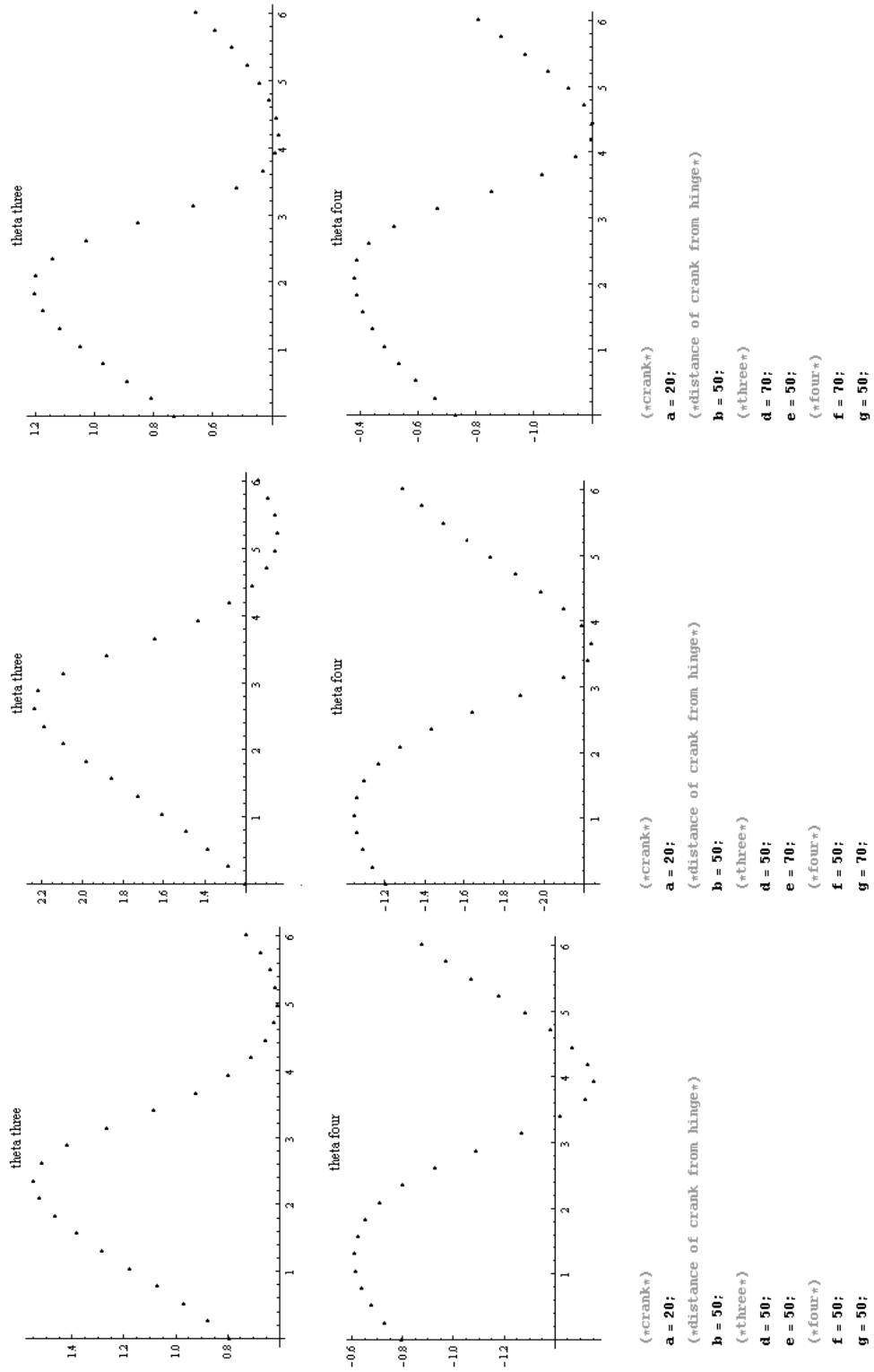

Figure C6: Comparison of 70:50 ratio of hinge and crank rods and resulting angular movement plotted.

Comparison of 30:50 ratio of rods

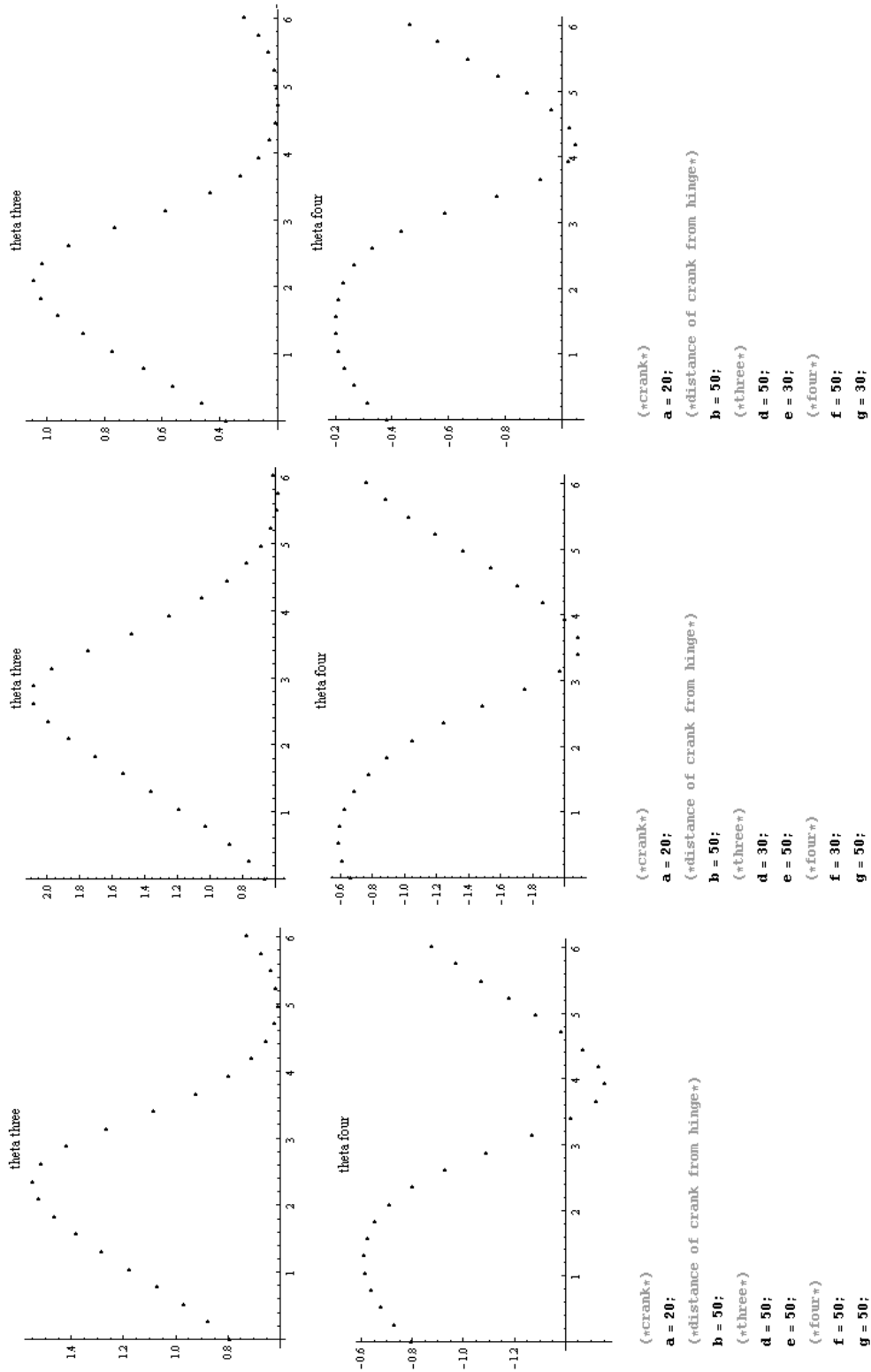

Figure C7: Comparison of 30:50 ratio of hinge and crank rods and resulting angular movement plotted.

Comparison of long and short rods

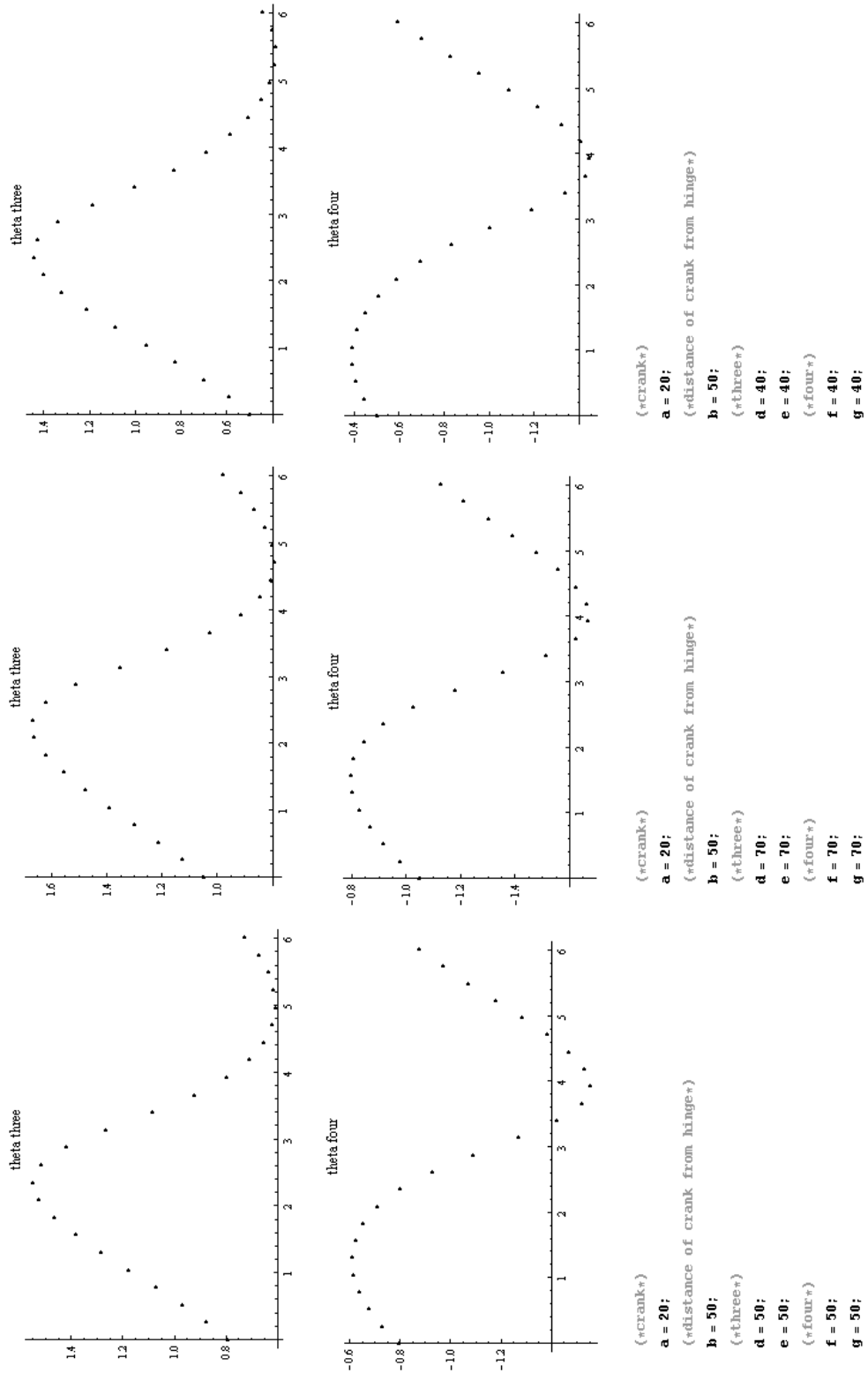

Figure C8: Comparison of long and short rods and resulting angular movement plotted.

Appendix D: Optimization of Four Bar Linkage #2

This appendix contains a sample of the plots I generated during the optimization of four bar linkage #2. Numbering and naming system is given below.

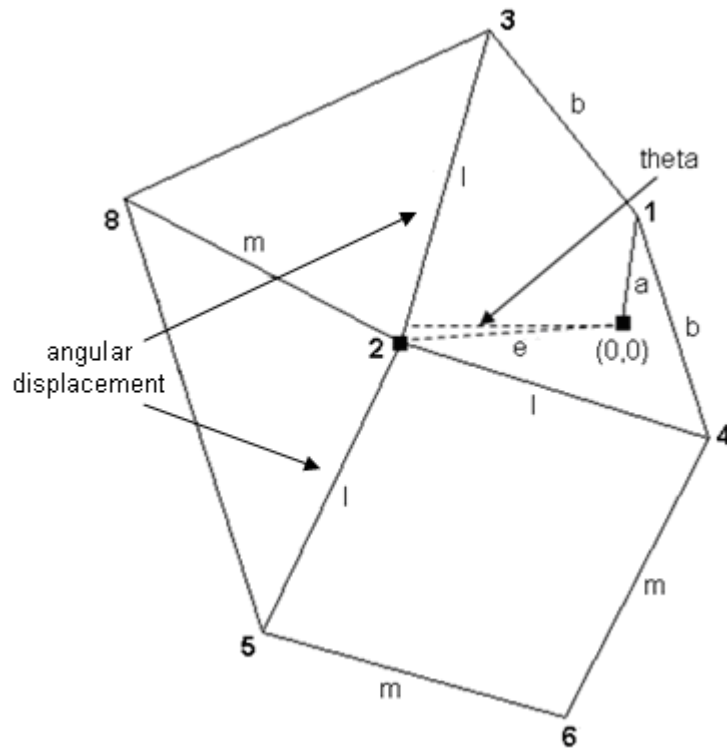

Figure 5.4.1: Naming and numbering system for full linkage optimization.

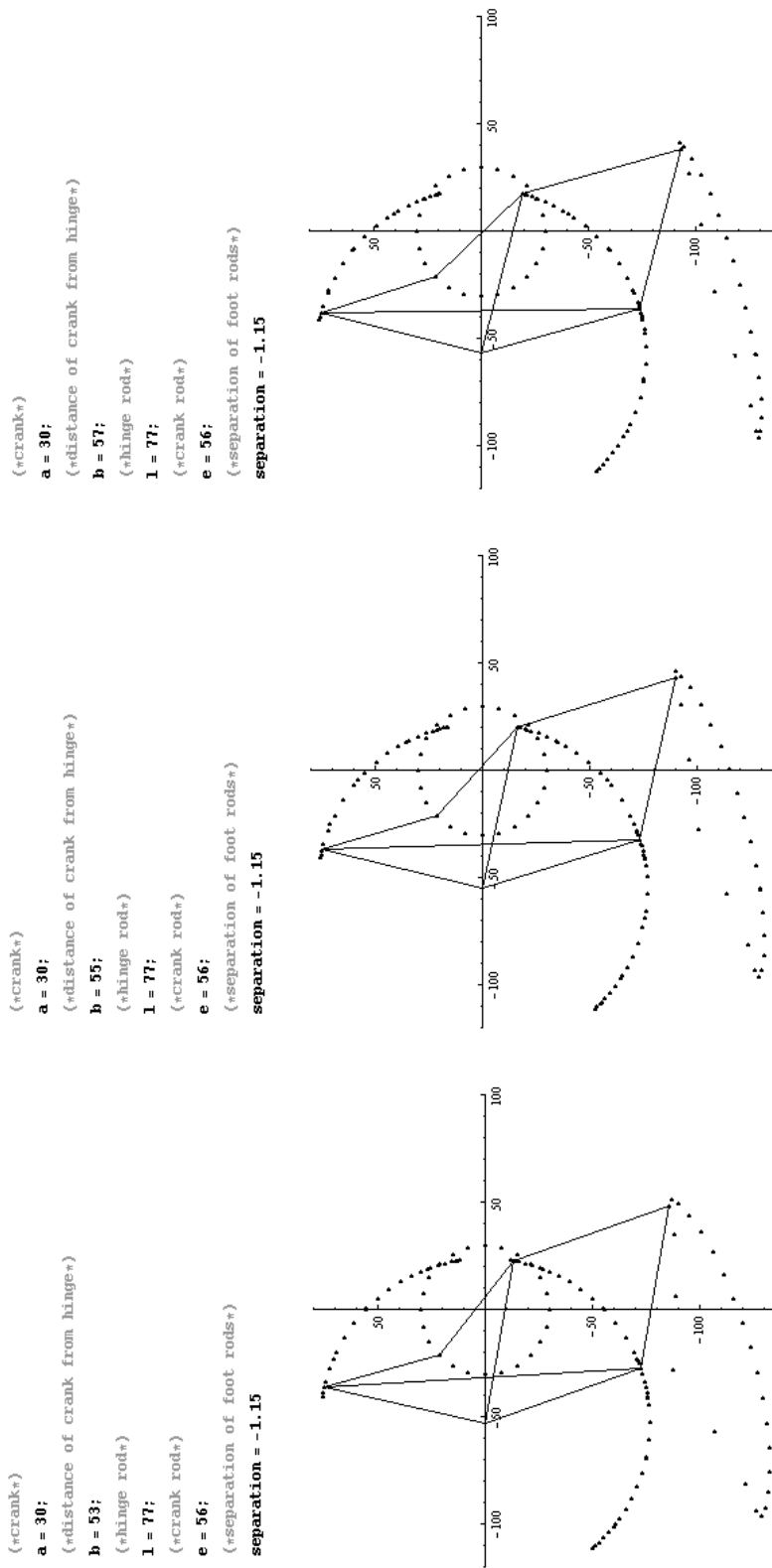

Figure D1: Changing b.

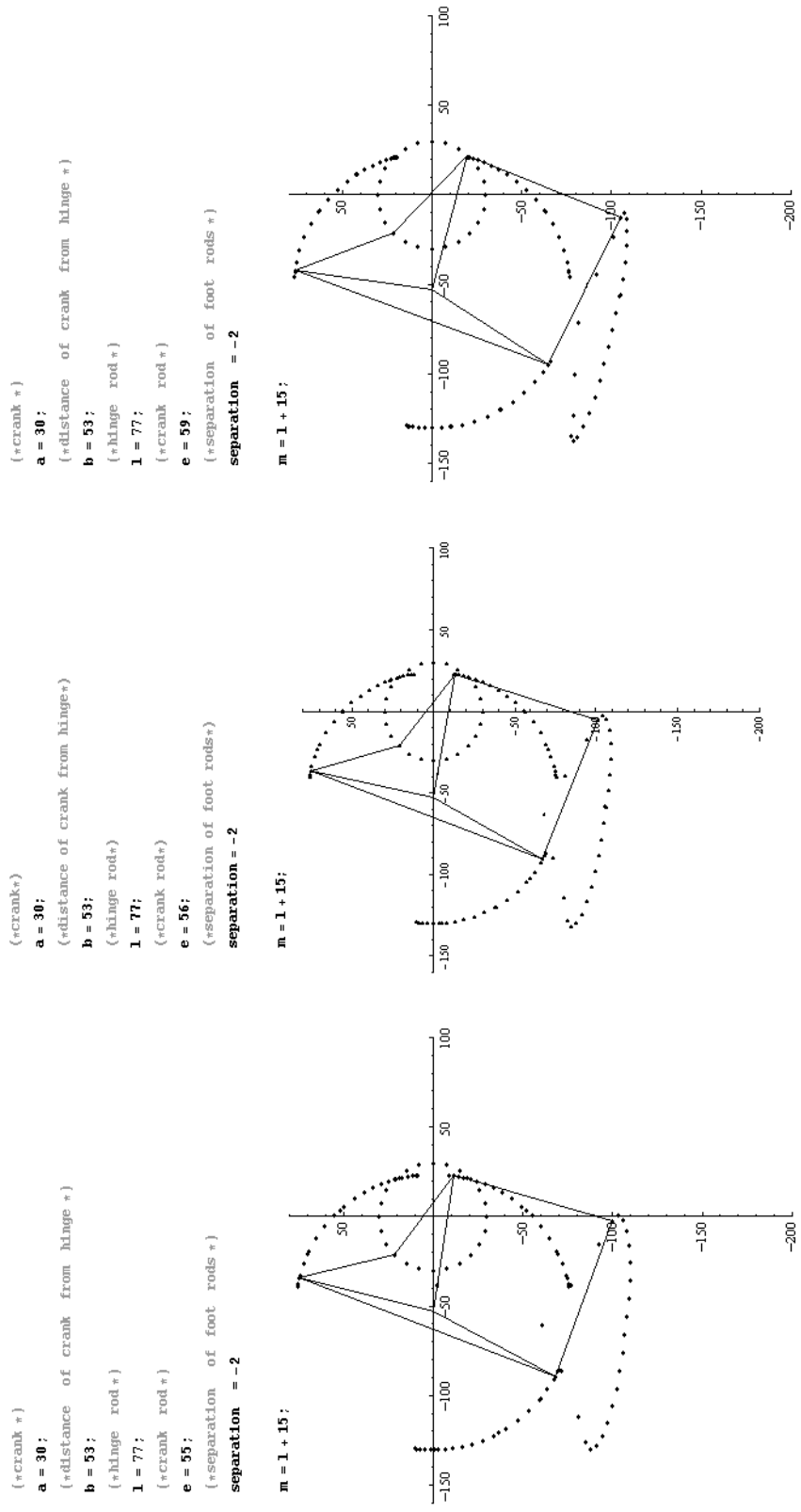
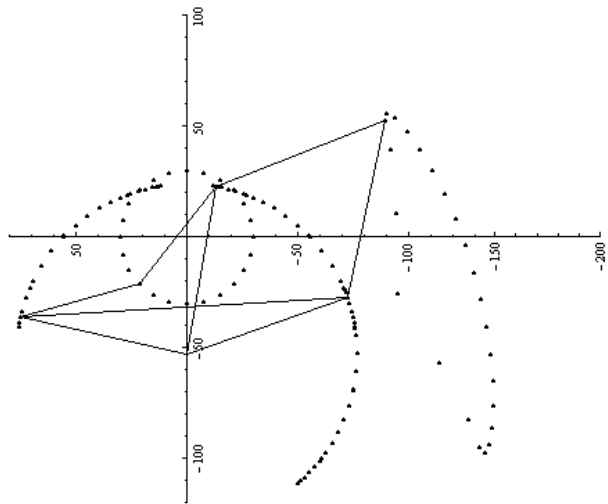

Figure D2: Changing e.

```

(*crank*)
a = 30;
(*distance of crank from hinge*)
b = 53;
(*hinge rod*)
l = 77;
(*crank rod*)
e = 56;
(*separation of foot rods*)
separation = -1.15
m = l + 5;

```



```

(*crank*)
a = 30;
(*distance of crank from hinge*)
b = 53;
(*hinge rod*)
l = 77;
(*crank rod*)
e = 56;
(*separation of foot rods*)
separation = -1.15
m = l + 15;

```

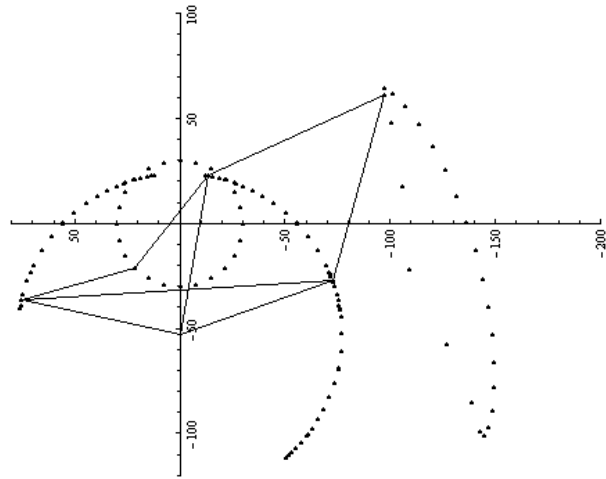

```

(*crank*)
a = 30;
(*distance of crank from hinge*)
b = 53;
(*hinge rod*)
l = 77;
(*crank rod*)
e = 56;
(*separation of foot rods*)
separation = -1.15
m = l - 15;

```

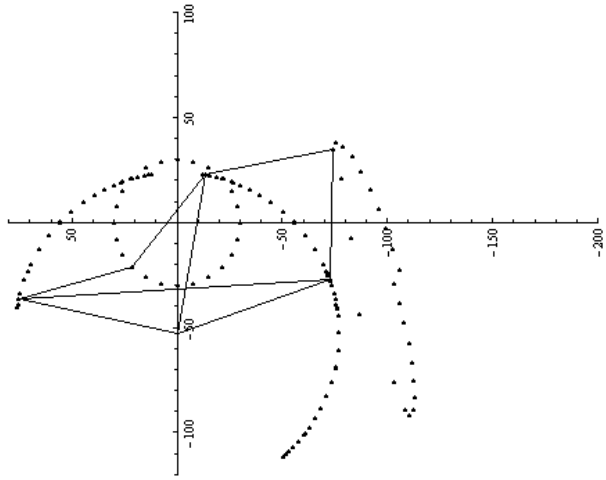

Figure D3: Changing m value.

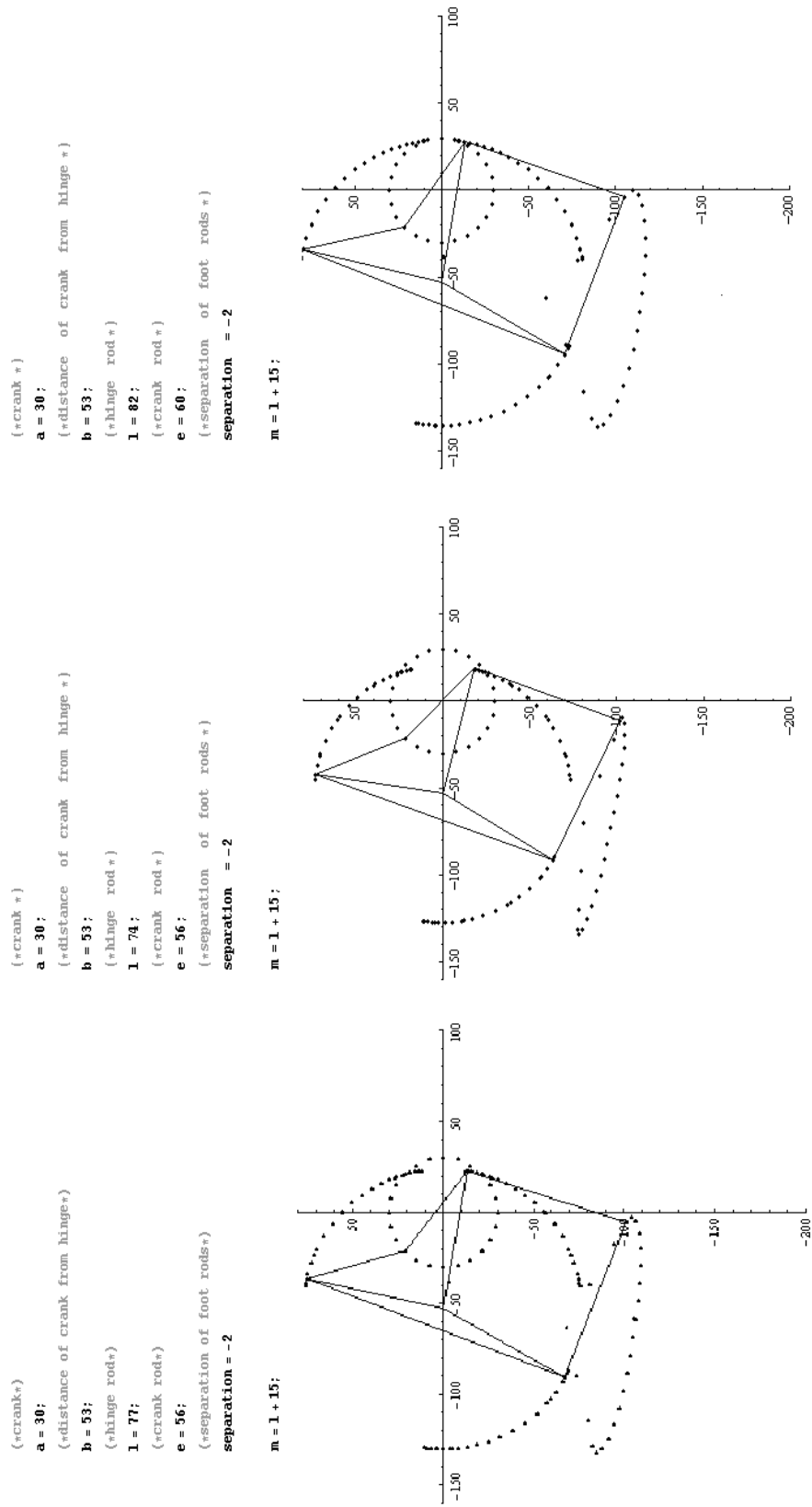
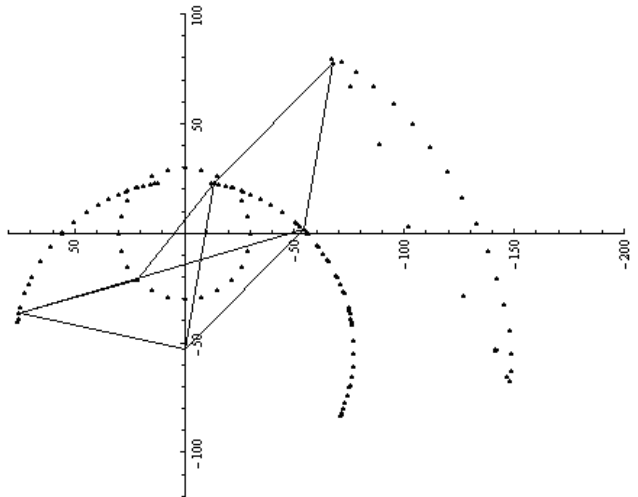
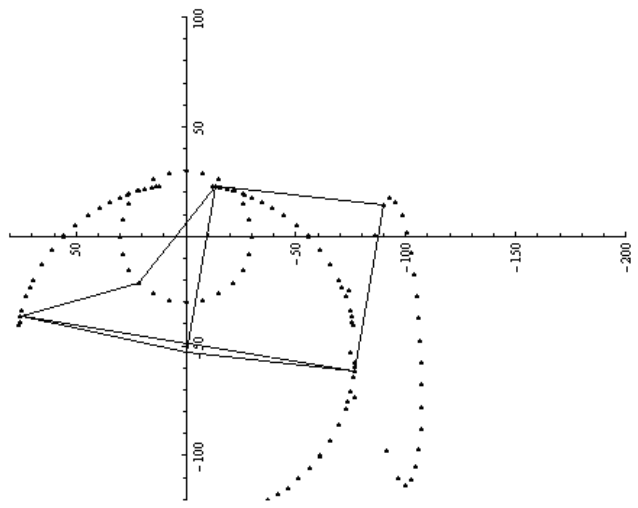

Figure D4: Changing l value.

```
(+crank*)
a = 30;
(+distance of crank from hinge*)
b = 53;
(+hinge rod*)
l = 77;
(+crank rod*)
e = 56;
(+separation of foot rods*)
separation = -.7
```



```
(+crank*)
a = 30;
(+distance of crank from hinge*)
b = 53;
(+hinge rod*)
l = 77;
(+crank rod*)
e = 56;
(+separation of foot rods*)
separation = -1.6
```



```
(+crank*)
a = 30;
(+distance of crank from hinge*)
b = 53;
(+hinge rod*)
l = 77;
(+crank rod*)
e = 56;
(+separation of foot rods*)
separation = -1.9
```

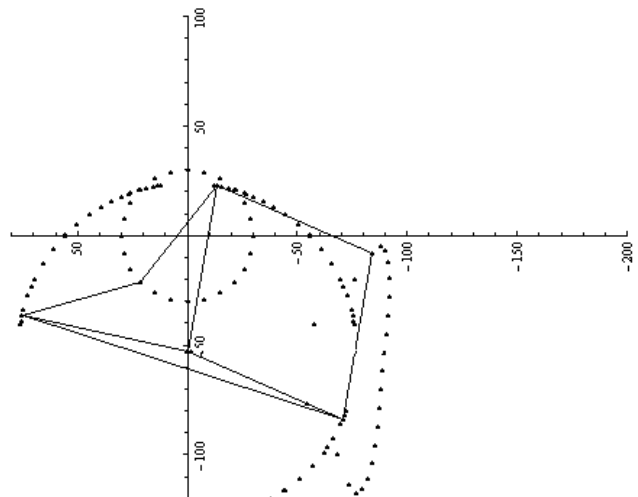

Figure D5: Changing “separation.”

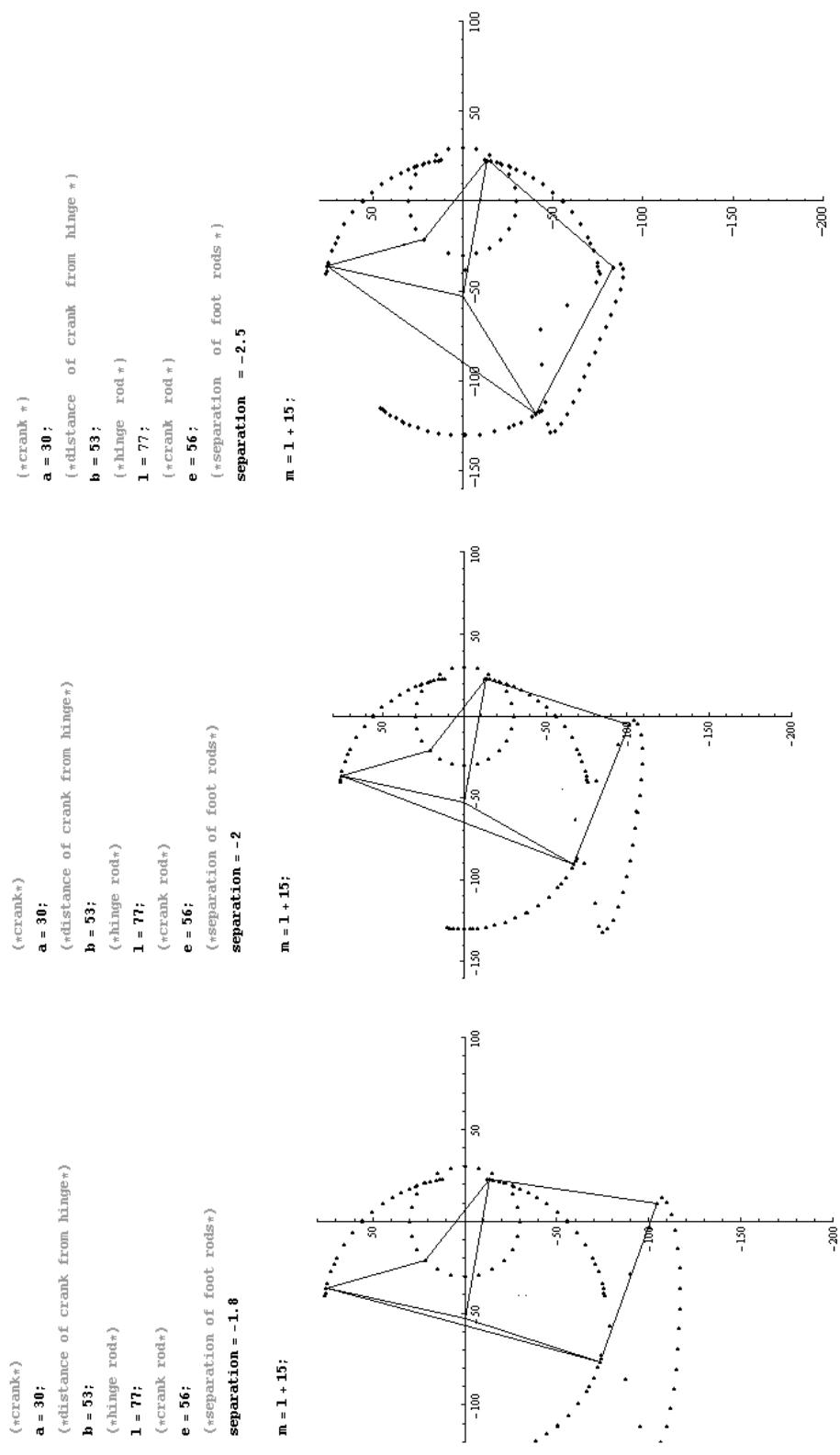

Figure D6: Large m, changing “separation.”

Works Cited

¹Jansen, Theo. The Great Pretender. *Uitgeverij*. 2007.

²Shigley, Joseph E. “The Mechanics of Walking Vehicles: A Feasibility Study.”
University of Michigan Department of Mechanical Engineering. 1960.

³Song, Shin-Min, and Kenneth J Waldron. Machines That Walk: The Adaptive Suspension Vehicle. *MIT Press*. 1988